

Research Report

AN EXPERIMENTAL TEST OF EVENT COMMUTATIVITY IN DECISION MAKING UNDER UNCERTAINTY

Ngar-Kok Chung,¹ Detlof von Winterfeldt,¹ and R. Duncan Luce²¹Institute of Safety and Systems Management, University of Southern California, and ²Institute for Mathematical Behavioral Sciences, University of California, Irvine

Abstract—A fundamental rationality assumption of many models of choices under risk and uncertainty is that the sequencing of events should not matter to a decision maker so long as the consequences arise under the same conditions, ignoring the order of events. Subjective expected utility (SEU) implies this property without exception; however, SEU is known not to be descriptive. The boundary between SEU and potentially more descriptive theories, such as the rank-dependent ones, has been shown to lie at a very simple version of this property called event commutativity. Two previous tests of it have yielded mixed results (Brothers, 1990; Ronen, 1973), but with some evidence from Brothers that it may be sustained if choice-based certainty equivalents are used. The present study tested event commutativity using a version of the sequential choice procedure Brothers employed in his third experiment. Twenty-four gambles representing a scenario of suing versus settling a car-accident dispute were presented to students, and certainty equivalents (settlement amounts) were elicited using a computer-controlled choice procedure. Twenty-two of 25 subjects supported the property of event commutativity; the others violated it in ways similar to those discovered in the earlier studies.

Assumptions about rational choices among risky or uncertain alternatives can be classified into two distinct types: (a) preference rationality assumptions, which are assumptions that follow from the general principle that replacing something by something better is always desirable (concepts included in this category are transitivity, consequence

monotonicity, and event monotonicity¹); and (b) a universal structural rationality assumption, which asserts that the decision maker should be indifferent among all formally equivalent descriptions of a gamble (e.g., between its extensive and normal forms).²

In sufficiently rich contexts of alternatives, preference and universal structural rationality can be shown to be equivalent to some version of the subjective expected utility (SEU) representation (Fishburn, 1982; Savage, 1954). Such a representation entails constructing a utility function over consequences and a (subjective) probability measure over events such that the expectation of the utility of an alternative relative to the constructed measure faithfully reflects the preference ordering. Note the direction of this assertion: The preference ordering is reflected by SEU; SEU is not the source of the ordering.

Considerable empirical evidence (Kahneman & Tversky, 1979; Luce, 1992; Schoemaker, 1982, 1990) makes clear that, whatever its normative status may be, the SEU model fails to be descriptive of human decision making. In particular, event monotonicity was rejected early on (Ellsberg, 1961), whereas in the absence of universal structural rationality, consequence monotonicity appears to be sustained (Kahneman & Tversky, 1979; von Winterfeldt, Chung, Luce, & Cho, 1994). So, one problem is to decide whether some rather more

restrained version of structural rationality obtains and to discover what sorts of descriptive representations are possible within that framework. The purpose of this report is to localize in terms of structural rationality assumptions the dividing line between SEU and other more descriptive theories (Luce, 1990).

Let $x_{OE}y$ denote the binary gamble that yields the pure consequence x when some event E occurs and y when it fails to occur.³ Second-order gambles can be created by applying the operation \circ_E to all first-order gambles and pure consequences, and higher order gambles can be defined recursively.⁴ If \sim denotes indifference, the three simplest structural rationality properties are

Idempotence:

$$x_{OE}x \sim x.$$

Complementarity:

$$x_{OE}y \sim y_{\neg E}x.$$

Event commutativity:

$$(x_{OD}y)_{\circ E}y \sim (x_{OE}y)_{\circ D}y.$$

It is difficult to imagine descriptive violations of idempotence and complementarity. Event commutativity is slightly more complex; it simply says that for any gamble in which the consequence x arises when D and E both occur in two separate experiments and y arises otherwise, the order in which the experiments are conducted is immaterial to the decision maker. Once one invokes structural rationality conditions more complex than event commutativity, then in the

1. Precise definitions of these three concepts can be found in, for example, Luce (1990).

2. Luce (1990) referred to these as *accounting equivalences*. In the context of known probabilities (risk), the probability calculation called the *reduction of compound gambles* is an example of structural rationality. Indeed, if risky money gambles are treated as random variables, which is common in economics, universal structural rationality is built into the formulation of the problem.

3. Other common notations for this gamble are $(x, E; y, \neg E)$, where \neg means "not," and the slightly abbreviated variant $(x, E; y)$.

4. Whenever a compound gamble such as $(x_{OE}y)_{\circ D}z$ appears, the intended interpretation is that two independent experiments are conducted, the first governing whether or not D occurs and the second whether or not E occurs. If $D = E$, independent experiments are still run for each E .

Address correspondence to Detlof von Winterfeldt, Institute of Safety and Systems Management, University of Southern California, University Park, Los Angeles, CA 90089.

presence of the other assumptions one is forced back to SEU and, therefore, to universal structural rationality (Luce & Narens, 1985). In particular, this is true if the following holds:

Right autodistributivity:

$$(xOEy)OEz \sim (xOEz)OE(yOEz).$$

Brothers (1990) tested right autodistributivity and showed it to be violated systematically, as one would anticipate from the Luce and Narens (1985) result and the known descriptive failure of SEU.

So the dividing line at event commutativity becomes of interest. One type of model satisfying event commutativity, but not any of the stronger structural conditions, is known as rank-dependent utility (RDU); variants of it were studied, mostly by economists, during the 1980s (for references, see Luce, 1992; for a thorough review, see Quiggin, 1993).

Table 1 summarizes the empirical findings to date vis-à-vis SEU and RDU. In sum, the major propositions underlying RDU theory, except possibly event commutativity, appear to be sustained descriptively. SEU theory appears violated primarily by failures of right autodistributivity (as well as other, more complex structural rationality conditions) and event monotonicity.

The empirical uncertainty about event commutativity centers on studies of Ronen (1973) and Brothers (1990), both of whom explored its descriptive

validity, ending up with somewhat mixed findings (see the next section). Because we had some concern about the methods used in these earlier studies, we studied event commutativity once again, using more stimuli and a choice-based method for determining indifference.

PREVIOUS TESTS OF EVENT COMMUTATIVITY

In this section, we discuss in greater detail the nature of the event commutativity assumption, possible psychological reasons for its failing in practice, previous empirical research on it, and our research hypotheses.

The nature of the event commutativity assumption is best explained by presenting the two gambles in event-tree form (see Figs. 1a and 1b). Both gambles result in the consequence *x* when events *E* and *D* both occur; the other three combinations of events lead to consequence *y* (see Fig. 1c). The only difference between the gambles of Figure 1a and Figure 1b is the order in which the events *E* and *D* occur. Although the bottom lines are identical, the order may nonetheless matter psychologically, when a person exhibits a clear preference for or aversion to moving on to the second stage. Suppose *x* is preferred to *y* and *E* is substantially more probable than *D*. A subject who likes to gamble may prefer having *E* first and then *D* because that is more likely to lead to "a second chance" at winning *x*.

Ronen (1973) tested this assumption in two experiments. In the first, he presented 22 subjects with 20 direct choices between pairs of gambles like those in Figure 1. The consequence *x* was a fixed small dollar amount (\$0.40), and *y* was always \$0. The probabilities of *D* and *E* were varied among the pairs. Subjects were instructed simply to indicate their preference within each pair of gambles. After all choices had been made, the 20 gambles selected by each subject were played, and the subject was paid off according to the chance-determined outcomes (for a maximum of \$8.00). Three subjects always selected the gamble that gave them the higher chance of entering the second stage, and thus the possibility of winning *x*. Of the remaining 19 subjects, 16 also more often than not selected the gamble having the higher initial chance. In a second experiment, Ronen asked 96 business students to evaluate hypothetical business ventures that could either lead to success (*x* was described in words, not dollars) or maintain the status quo (*y* was described as a no-gain, no-loss outcome without stating a dollar amount). Subjects were again asked to make direct choices in 24 pairs of gambles that differed only in the sequencing of the events, as in Figure 1. As found in Experiment 1, the majority of the subjects (70%) more often selected the gamble with the higher probability of getting to the second stage.

Brothers (1990) conducted three experimental tests of event commutativity

Table 1. Status of preference and structural rationality assumptions

Assumption	Subjective expected utility	Rank-dependent utility	Data
Preference rationality:			
Transitivity	Yes	Yes	Yes (choice data ^a)
Consequence monotonicity	Yes	Yes	Yes (choice data ^a)
Event monotonicity	Yes	No	No
Structural rationality:			
Idempotence	Yes	Yes	Probably
Complementarity	Yes	Yes	Probably
Event commutativity	Yes	Yes	Inconsistent
Autodistributivity	Yes	No	No

Note. This table is adapted from Luce and von Winterfeldt (1994). Each table entry indicates whether the property in question is satisfied by the model or appears to be satisfied in the data. ^aThe intended contrast is with gambles evaluated by some form of judged certainty equivalent.

Experimental Test of Event Commutativity

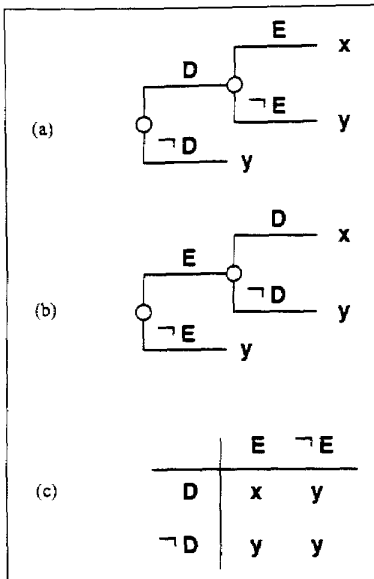

Fig. 1. Three versions of the same two-stage gamble. (a) Gamble a represents a two-stage gamble with consequences *x* and *y* generated by events *D* and *E*, with *D* at the first stage. (b) Gamble *b* reverses the order of *D* and *E*. (c) The tabular display presents event combinations and the respective consequences, *x* or *y*, generated by *D* and *E*.

that differed in response mode: direct preference, judged certainty equivalents, and certainty equivalents derived from choices using a special procedure described below. In his first experiment, 30 subjects compared the two-event commutativity gambles, side by side, and stated whether they had a preference and, if so, how strong it was. The hypothetical consequences ranged from -\$1,000 to +\$1,000, and the gambles were varied systematically in consequences and probabilities to cover a wide range of combinations. Seven of the 30 subjects seemed to recognize the equivalence of the pairs and showed little or no strength of preference. Eight subjects exhibited systematic patterns of preference, mostly selecting the gamble with the higher chance of getting into the second stage when it promised a higher payoff. Fifteen subjects showed inconsistent responses that certainly were not rational and did not seem to follow any clear pattern.

In the second experiment, Brothers

(1990) used a similar set of stimuli, but asked subjects in the event commutativity test to assign certainty equivalents independently to the two gambles in a pair. Contrary to his expectation, subjects showed a tendency to assign a higher certainty equivalent to gambles having a lower probability of winning at the first stage (and, consequently, a higher one of winning at the second stage). He suggested that judging certainty equivalents directly may introduce a response-mode bias, as had been demonstrated in a different context of so-called preference reversals (Bostic, Herrnstein, & Luce, 1990).

Because of this concern about response-mode biases, Brothers used the special choice procedure of Bostic et al. (1990) to elicit certainty equivalents. In this procedure, subjects go through a sequence of choices that eventually homes in on a narrow indifference range, the mean of which is taken to be the choice indifference point. Because the procedure is somewhat elaborate and time-consuming, Brothers carried it out for only four examples of event commutativity. His data supported event commutativity. Moreover, when these subjects judged certainty equivalents directly for the same stimuli, the effect of overvaluing gambles with the smaller first-stage probabilities appeared once again.

Thus, the jury is still out on event commutativity. The demonstrated violations of event commutativity in Ronen's (1973) and Brothers's (1990) experiments may have been due to clear preferences for gambles that present a higher probability of getting into the second stage or due to a response-mode bias with judged certainty equivalents. The apparent lack of an effect when a choice procedure was used is intriguing, but because there were only four tests, we do not consider that result conclusive.

We decided to use a choice procedure again to test event commutativity, but on a richer and larger set of stimuli. Our main hypothesis was that, when a suitable choice procedure is used, event commutativity is valid. Our main alternative hypothesis was that possible violations would show up as a tendency for subjects to prefer the gamble giving them the higher chance of getting into the second stage of the gamble. We suspected that this tendency would be especially

strong when *x* was both positive and significantly larger than *y* and the probability of *E* was much larger than the probability of *D*. We therefore created stimuli that would magnify this effect, should it occur.

Embedded in our design was a secondary issue: Does event commutativity hold without restriction, or only for gambles yielding just gains (or just losses, which we did not study)? This issue is of interest because some evidence has led to the development of a class of rank- and sign-dependent utility (RSDU) representations in which the status quo plays a significant role and rank-dependence holds only for gains and losses separately but not for the mixed case (Cho, Luce, & von Winterfeldt, 1994; Kahneman & Tversky, 1979; Luce, 1991; Luce & Fishburn, 1991; Tversky & Kahneman, 1992). Although event commutativity for gambles with mixed gains and losses is not predicted by such theories, the size of the discrepancy depends critically on the exact utility and weighting functions over events,⁵ so we did not know the magnitude of the failure we were seeking. For this reason, this issue was secondary in the experimental design.

METHOD

Subjects

Twenty-five subjects were recruited through the campus newspaper at the University of Southern California. All were paid a flat fee of \$7.50 for participating in the experiment.

Stimuli and Stimulus Presentation

The following scenario was used in testing the commutativity hypothesis:

Imagine you are in court for a dispute over a car accident you were involved in. It is not clear to you which party was at fault, and neither you nor the other driver admit fault. However, there are two independent witnesses, A and B. You honestly do not know for sure whether these witnesses would testify

5. In these theories, the weights are not additive measures and so are not probabilities.

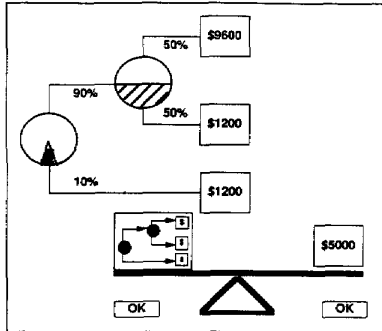

Fig. 2. Computer display of the stimulus for the car-accident dispute. The left side of the balance represents the gamble (fight) scenario, and the right side represents the sure-thing (settle) outcome. The leftmost gamble is the uncertainty of witness A, and the gamble following is the uncertainty of witness B. Probabilities of favorable and unfavorable testimonies are indicated at the top and bottom branches, respectively. Dollar amounts in the boxes indicate the corresponding consequences. Subjects are to indicate their preference for the gamble or sure thing by clicking the corresponding "OK" button.

for or against you during the trial. You do know, however, the probability of a favorable testimony from A and the probability of a favorable testimony from B. If witness A testifies in your favor, witness B will be called and will either testify for or against you. If A testifies against you, witness B will not be called upon to testify and the judgment will be made solely on the basis of witness A's testimony.

If both witness A and B are favorable, you will receive the amount \$X. X is always a positive amount. If A is favorable, but B unfavorable, you will receive or, in some instances, pay the amount \$Y. If A is unfavorable, B will not be called upon to testify, and you will receive or pay the amount \$Y. During a court recess, but prior to the appearance of the witnesses, the other party offers to settle the case out of court. The money you will receive (or pay) for sure by taking this sure option is \$Z. Disregarding other factors, such as hassle, from the standpoint of pure gains or losses of money and the probabilities involved, will you fight or will you settle?

All stimuli—gambles (fight) and sure consequences (settle)—were presented on a 13-in. Macintosh computer screen, as shown in Figure 2. The sure consequence was always on the right side and the gamble on the left side. The pie segments that represented the uncertain events in the gamble were scaled so as to correspond in size to the numerical probabilities shown in the display, with the filled segments, which on the computer screen were blue in the first gamble and red in the second, proportional to their respective probabilities. The areas for dollar amounts were shaded in green. An icon representing the gamble was presented on the balance below its "blown up" version; the sure thing was shown on the right side of the balance.

The choice procedure we used, called parameter estimation by sequential testing (PEST), was similar to that first employed in a preference context by Bostic

et al. (1990) and used later by Brothers (1990). It involved separate up-down adjustment procedures conducted independently for each gamble, but with successive steps on one procedure separated by presentations of many other gambles. At the first presentation of a gamble, the computer selected a sure-thing value according to a uniform distribution over the interval of integers between the minimum and the maximum amounts of the gamble. Each subject was instructed to click the "OK" button corresponding to whether the gamble (fight) or the sure thing (settle) seemed the better option. Once that response was entered, the computer algorithm calculated a second sure-thing amount by taking a fixed step in the direction of indifference; the size of the step was equal to 1/5 of the range between the minimum and the maximum consequences of the gamble. For example, with the stimulus of Figure 2, the initial step is \$1,680 = (\$9,600 - \$1,200)/5. If a subject had selected the sure thing of \$5,000, the next sure-thing amount presented would be \$3,320 = \$5,000 - \$1,680; alternatively, if the subject had selected the gamble, the second sure-thing amount would be \$6,680 = \$5,000 + \$1,680.

The second presentation of a particular gamble, with the modified sure-thing amount, was well separated from the first one by trials involving other gambles (see below). After the subject made a choice at the second presentation of a gamble, the procedure calculated the

Table 2. The 12 gamble pairs used to test event commutativity and their expected values

Gamble pair	Gamble a: ((x,p;y),q;y)	Gamble b: ((x,q;y),p;y)	Expected value
Pure gain			
1	((9600, .90;4800), .50;4800)	((9600, .50;4800), .90;4800)	6960
2	((9600, .75;4800), .33;4800)	((9600, .33;4800), .75;4800)	5988
3	((9600, .90;4800), .05;4800)	((9600, .05;4800), .90;4800)	5016
4	((9600, .90;1200), .50;1200)	((9600, .50;1200), .90;1200)	4980
6	((9600, .75;1200), .33;1200)	((9600, .33;1200), .75;1200)	3279
8	((9600, .90;1200), .05;1200)	((9600, .05;1200), .90;1200)	1578
Mixed gain and loss			
5	((9600, .90; -1200), .50; -1200)	((9600, .50; -1200), .90; -1200)	3660
7	((9600, .90; -2400), .50; -2400)	((9600, .50; -2400), .90; -2400)	3000
9	((9600, .75; -1200), .33; -1200)	((9600, .33; -1200), .75; -1200)	1473
10	((9600, .75; -2400), .33; -2400)	((9600, .33; -2400), .75; -2400)	570
11	((9600, .90; -1200), .05; -1200)	((9600, .05; -1200), .90; -1200)	-714
12	((9600, .90; -2400), .05; -2400)	((9600, .05; -2400), .90; -2400)	-1860

Experimental Test of Event Commutativity

new sure-thing amount for the next presentation of that gamble, and so on. However, as the sequence involving a particular gamble unfolded, the step size varied depending on the pattern of previous responses. If the subject preferred either the sure thing or the gamble for the three immediately preceding opportunities, the step size was doubled. If the subject changed the choice between successive presentations of that gamble, the step size was halved. If the calculated sure thing fell outside the range of consequences of the gamble and a subject made a wrong choice (e.g., selecting the sure thing, even though it was worse than the worst consequence of the gamble), the computer alerted the subject to the mistake and asked for a revision. The procedure for a particular gamble ended when the step size was smaller than 1/50 of the range of its consequences. After that, that particular gamble was no longer presented.

To help give the appearance of unrelated presentations, we incorporated into the PEST procedure some filler items designed to maintain a constant average recurrence time between successive presentations of each test stimulus. Initially, there was a pool of 24 test stimuli, plus another pool of 16 filler items. These filler stimuli, which were similar to the test stimuli except for having different probabilities and consequences, were interspersed among the test stimuli in a random fashion as follows. After each trial, whether test or filler, the computer algorithm chose at random with a probability of .25 and without replacement one of the filler stimuli from the remaining pool of filler stimuli; and with probability .75 the computer went on to the next regular test stimulus. When the pool was exhausted, the initial pool was reinstated. Thus, the number of remaining filler items varied between tests, and, more important, even after most test items were completed, there were still enough fillers to mask the nature of the sequencing.

Design

The 24 stimuli and their respective expected values are shown in Table 2. These stimuli were constructed by crossing two levels of favorable probabilities,

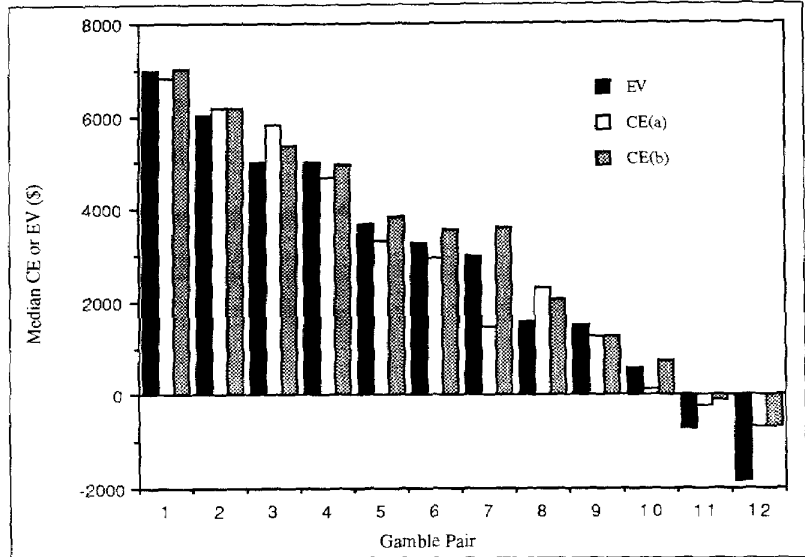

Fig. 3. Comparison of median certainty equivalents (CEs) and expected value (EV) for each gamble pair ($N = 25$). CE(a) and CE(b) are the median CEs of gambles with lower and higher probabilities of advancing to the second stage, respectively.

p (.9 and .75), and three less favorable ones, q (.5, .33, and .05), and their respective consequences, x (\$9,600) and y (\$4,800, \$1,200, -\$1,200, and -\$2,400). The probabilities were chosen to cover most of the range from 0 to 1. The consequences were chosen to cover both gain and mixed gain-loss scenarios. The a and b versions of a gamble pair differed simply in the order with which p and q were used. The initial order of all 24 stimuli was randomized separately for each subject.

Note that if either SEU or RDU is valid, event commutativity should hold for all gambles; but if RSDU is valid, then it needs to hold only for gambles with $y > 0$.

Procedure

Subjects were first introduced to the experiment, the scenario, the display, and the response mode. Several trial items were presented, and the experimenter supervised the subjects' responses to these trial items, responded to questions, and corrected obvious response errors. The experimenter instructed subjects that they should make their trial-by-trial judgments independently, as if making a unique decision

each time. They were encouraged to think of the dispute scenario and the amounts of money as a real situation. To help with the realism of the stimuli, they were also shown a physical display, in-

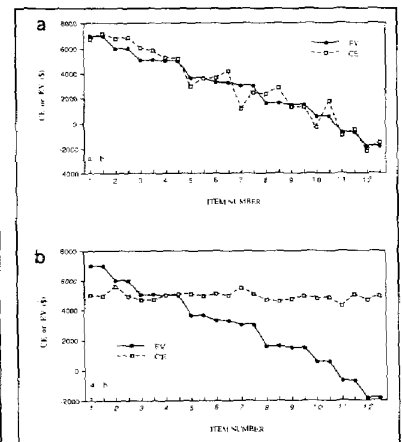

Fig. 4. Plots of certainty equivalents (CEs) and expected values (EVs) across items. The two markers for each item number on the x-axis are gambles a and b, respectively. For most subjects, CE followed EVs closely, as in the data for Subject 20 (a). A few subjects, however, had flat CE curves, as in the data for Subject 3 (b).

Table 3. Preference patterns over subjects for gamble type a (lower probability of advancing to the second-stage gamble) over gamble type b

Gamble pair	N	Percentage
Pure gain		
1	13	.52
2	11	.44
3	12	.48
4	8	.32
6	8	.32
8	10	.40
Mixed gain and loss		
5	15	.60
7	10	.40
9	15	.60
10	11	.44
11	12	.48
12	13	.52

Note. See Table 2 for a list of the gambles. N denotes the number of cases out of 25 for which a is chosen over b.

cluding a pointer as a random device, as a concrete realization of the schematic pie graphs previously demonstrated on the screen. The experimenter showed them how spinning the pointer could be used to determine the outcomes of the scenarios presented in the experiment. Subjects were run individually in single sessions lasting approximately 1 hr.

RESULTS

Figure 3 compares, as a bar chart, the median certainty equivalent (CE) and expected value (EV) for each gamble pair. CE(a) denotes the median CE of gamble type a, which is defined to be the one that had a lower probability (.05, .33, .50) of moving to the second stage, and so had a higher probability (.90 or .75) of winning \$x if the second stage was reached. CE(b) denotes the median CE of the other gamble type, denoted b.

Across all subjects, the median CE for each item follows its corresponding EV closely, except for gambles with negative EVs (loss of money in the dispute). When the EV is negative, subjects appear to be risk seeking, a tendency that has been seen in other studies as well.

More important, the CEs of the two gambles in each pair in the event commutativity test do not show any noticeable difference (for statistical tests, see below), except for Gamble Pair 7. In this pair, the gamble with the higher probability of getting into the second stage had a median CE of \$3,800, compared with \$1,800 for CE(a).

An analysis of individual subjects across gambles shows that, as expected, most subjects exhibited CEs close to the respective EVs of the gambles. Figure 4a shows a plot of EVs and the corresponding CEs for a typical subject. The plots for an additional 19 of the subjects showed a similar close association be-

tween EVs and CEs across gambles. However, 5 subjects had markedly flat CEs; Figure 4b shows 1 such subject. Apparently, these subjects established a response criterion, in this case of \$5,000, independently of the gamble. If these 5 subjects are omitted from the aggregate analysis of Figure 3, the medians align much more closely with the respective EVs of the gambles and with the commutativity assumption.

Table 3 shows the percentage of subjects who selected gamble type a over gamble type b (as inferred from their CEs) for each of the 12 pairs of gambles. Pure-gain and mixed gambles are displayed separately. The overall percent-

Table 4. Preference proportions over gamble pairs for gamble type a (lower probability of advancing to the second-stage gamble) over gamble type b, for individual subjects

Subject	Type of pair		
	Pure gain	Mixed	Combined
1	.50	.83	.67
2	1.00	.50	.75
3	.67	.33	.50
4	.33	.83	.58
5	.17	.83	.50
6	.33	.50	.42
7	.33	.50	.42
8	.17	.67	.42
9	.17	.00	.08
10	.83	.67	.75
11	.33	.83	.58
12	.50	.67	.58
13	.00	.00	.00
14	.17	.50	.33
15	.50	.17	.33
16	.33	.83	.58
17	.67	.50	.58
18	.00	.33	.17
19	.50	.17	.33
20	.33	.17	.25
21	.50	.83	.67
22	.50	.17	.33
23	.33	.50	.42
24	.50	.67	.58
25	.67	.67	.67
Mean (with outliers)	.41*	.51	.46
Mean (without outliers)	.41	.47	.44

Note. Subjects with flat certainty equivalent curves (outliers) are underlined.

*Marginally significant, $t = -1.80$, $df = 24$, $p < .08$.

Experimental Test of Event Commutativity

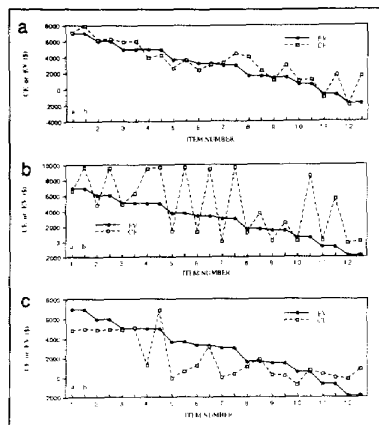

Fig. 5. Plots of certainty equivalents (CEs) and expected values (EVs) across items for 3 subjects who showed systematic violation of event commutativity. The two markers for each item number on the x-axis are gambles a and b, respectively. Subjects 9 (a), 13 (b), and 18 (c) tended to prefer gamble type b over gamble type a.

ages range from .32 to .60 (.32 to .52 for pure-gain gambles; .40 to .60 for mixed gambles). Chi-square tests show that none of these percentages differ significantly from .5. In addition, 12 paired *t* tests on the actual CEs between corresponding gambles across subjects are nonsignificant. Both tests provide evidence to support the commutativity hypothesis as descriptively correct when evaluated using choice procedures. Whether a gamble involves all gains or a mix of a gain and a loss does not seem to matter. The correlations between the CEs of the paired gambles across subjects are all high ($r = .55$ to $.95$) and significant.

Similarly, most subjects showed little or no tendency to prefer gamble type a to gamble type b (see Table 4). However, 3 subjects (9, 13, and 18) had a significant pattern of violations of commutativity, tending to choose gamble type b (higher probability of getting into the second-stage gamble) over gamble type a. For these 3 subjects, the percentages for which gamble type a was selected are 8%, 0%, and 17%, respectively, whereas for the other subjects they range from 25% to 75%. The CEs of these 3 subjects are plotted in Figure 5. Subject 13 (Fig. 5b) consistently assigned a much higher

CE to gamble type b than to gamble type a, and Subjects 9 and 18 tended also to assign higher values to gamble type b than to gamble type a, but in a less dramatic fashion than did Subject 13.

DISCUSSION

This experiment tested a crucial structural rationality assumption of decision making under uncertainty: event commutativity. This assumption is seen as crucial because it establishes a boundary between SEU and RDU theories. If it fails to hold, the class of RDU models is also descriptively wrong. The basic finding of this experiment is that event commutativity is largely sustained for gambles involving both pure gains and losses. Specifically, 22 of 25 subjects showed no tendency to select one or the other of the formally equivalent gambles in an event-commutativity pair.

Only 1 subject showed a marked deviation by always assigning higher CEs to the type b gamble, the one having a higher chance of getting into the second stage. Two others showed some deviation, but far less dramatically. The 3 subjects who violated event commutativity did so by choosing the gamble that gave them the higher probability of getting into the second stage, and thus winning the larger consequence, as was found earlier by Ronen (1973) and, in a less pronounced fashion, by Brothers (1990). Apparently, these subjects preferred to confront the higher probability first and the lower one second. Perhaps this preference reflects a desire to increase the enjoyment of gambling as opposed to a purely consequentialist attitude. To some extent, this tendency may be suppressed in decision contexts outside pure gambling, such as the lawsuit scenario used in the present study.

Overall, we feel that event commutativity was well sustained in this experiment. Thus, a major pillar of RDU theory seems to be descriptively sustained. From a normative or prescriptive perspective, it is encouraging to observe that subjects appear largely to ignore event order, even if the stimuli are designed to emphasize the potential for paying attention to such differences.

The data were inconclusive in deciding between RDU and RSDU.

Acknowledgments—This study was supported by the Decision, Risk and Management Science Program of the National Science Foundation under several grants: SES-8921494 and SBR-9308915 to the University of California, Irvine, and SBR-9308959 to the University of Southern California.

REFERENCES

- Bostic, R., Herrnstein, R.J., & Luce, R.D. (1990). The effect on the preference reversal phenomenon of using choice indifference. *Journal of Economic Behavior and Organization*, 13, 193-212.
- Brothers, A.J. (1990). *An empirical investigation of some properties that are relevant to generalized expected-utility theory*. Unpublished doctoral dissertation, University of California, Irvine.
- Cho, Y., Luce, R.D., & von Winterfeldt, D. (in press). Tests of assumptions about the joint receipt of gambles in rank- and sign-dependent utility theory. *Journal of Experimental Psychology: Human Perception and Performance*.
- Ellsberg, D. (1961). Risk, ambiguity and the Savage axioms. *Quarterly Journal of Economics*, 75, 643-669.
- Fishburn, P.C. (1982). *The foundations of expected utility*. Dordrecht, The Netherlands: Reidel.
- Kahneman, D., & Tversky, A. (1979). Prospect theory: An analysis of decision under risk. *Econometrica*, 47, 263-291.
- Luce, R.D. (1990). Rational vs. plausible accounting equivalencies in preference judgments. *Psychological Science*, 1, 225-234.
- Luce, R.D. (1991). Rank- and sign-dependent linear utility models for binary gambles. *Journal of Economic Theory*, 53, 75-100.
- Luce, R.D. (1992). Where does subjective expected utility fail descriptively? *Journal of Risk and Uncertainty*, 5, 5-27.
- Luce, R.D., & Fishburn, P.C. (1991). Risk- and sign-dependent linear utility models for finite first order gambles. *Journal of Risk and Uncertainty*, 4, 29-59.
- Luce, R.D., & Narens, L. (1985). Classification of concatenation structures according to scale type. *Journal of Mathematical Psychology*, 29, 1-72.
- Luce, R.D., & von Winterfeldt, D. (1994). What common ground exists for descriptive, prescriptive and normative utility theories? *Management Science*, 40, 263-279.
- Quiggin, J. (1993). *Generalized expected utility theory: The rank-dependent model*. Boston: Kluwer Academic Publishing.
- Ronen, J. (1973). Effects of some probability displays on choices. *Organizational Behavior and Human Performance*, 9, 1-15.
- Savage, L.J. (1954). *The foundations of statistics*. New York: John Wiley & Sons.
- Schoemaker, P.J.H. (1982). The expected utility model: Its variants, purposes, evidence and limitations. *Journal of Economic Literature*, 20, 529-563.
- Schoemaker, P.J.H. (1990). Are risk-attitudes related across domain and response modes? *Management Science*, 36, 1451-1463.
- Tversky, A., & Kahneman, D. (1992). Advances in prospect theory: Cumulative representation of uncertainty. *Journal of Risk and Uncertainty*, 5, 297-323.
- von Winterfeldt, D., Chung, N.-K., Luce, R.D., & Cho, Y. (1994). *Tests of consequence monotonicity in decision making under uncertainty*. Manuscript submitted for publication.

(RECEIVED 12/2/93; REVISION ACCEPTED 4/14/94)

This document is a scanned copy of a printed document. No warranty is given about the accuracy of the copy. Users should refer to the original published version of the material.