

Integrating conceptual and syntactic cues to understand the development of English verb classes

Lisa Pearl

University of California, Irvine

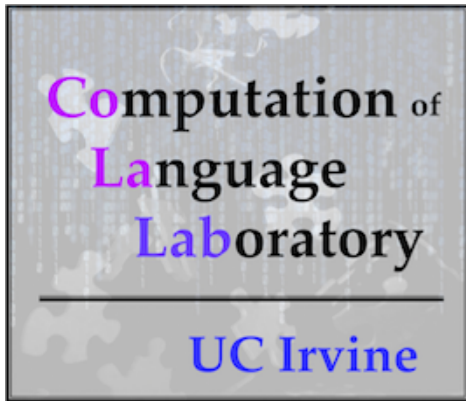

July 24, 2017

Symposium on advances in distributional models of language and meaning (Math Psych/ICCM)

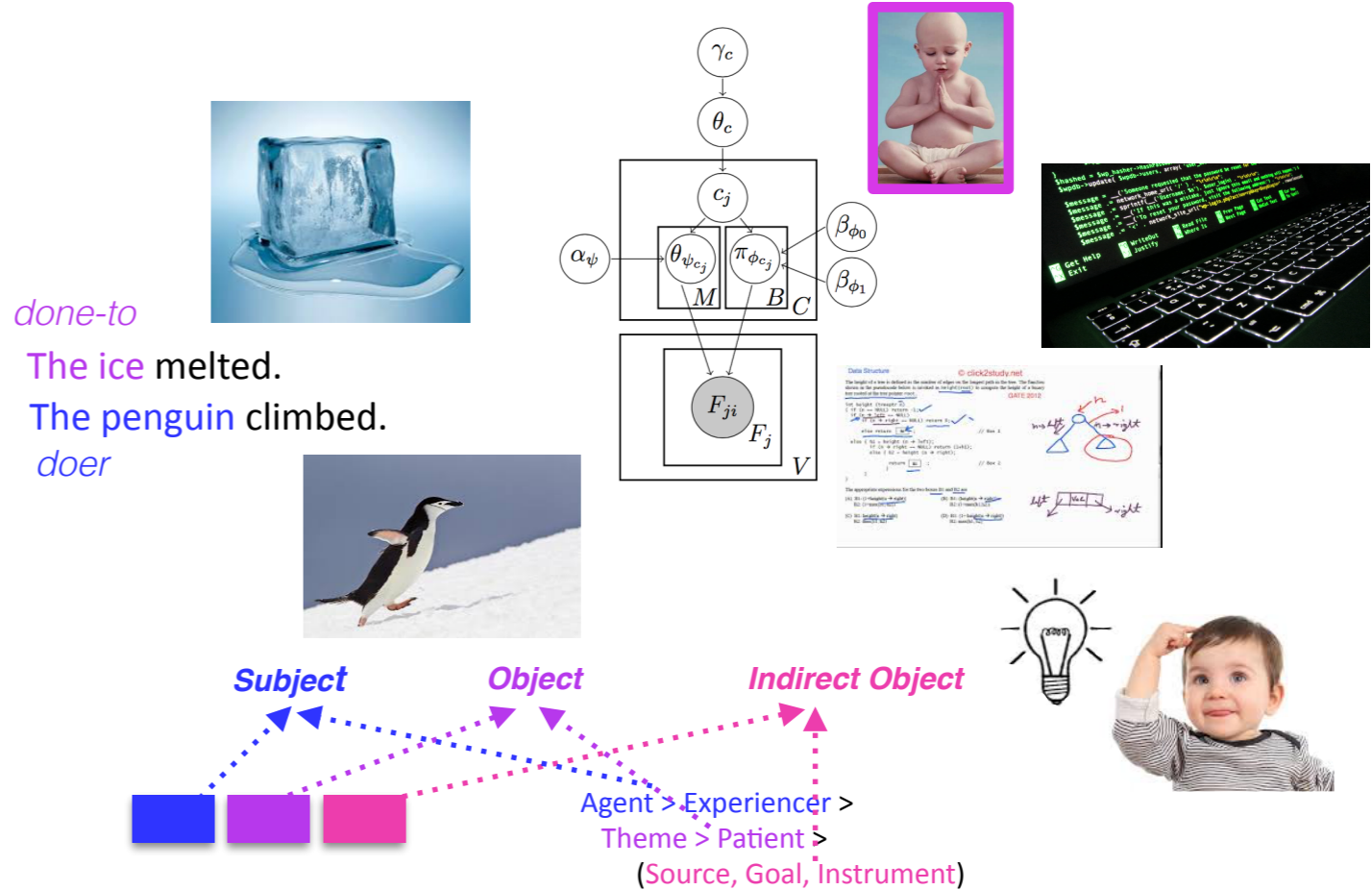

Today's plan

Verb classes



done-to

The ice melted.

The penguin climbed.

doer



Computational modeling

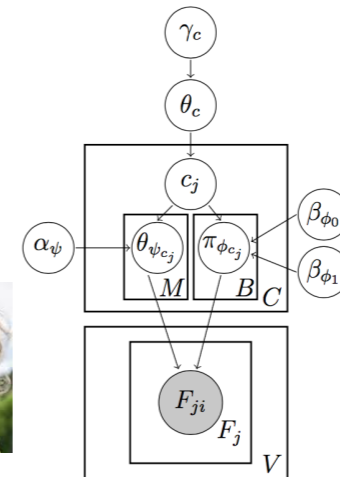
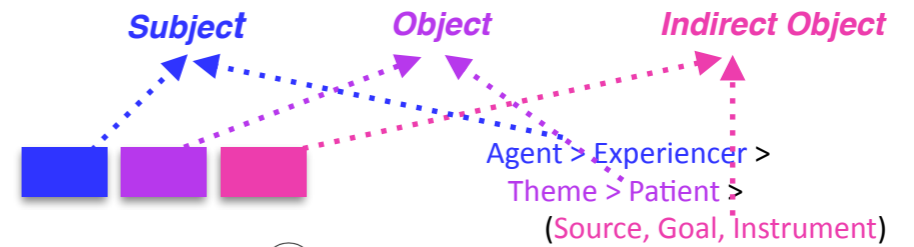
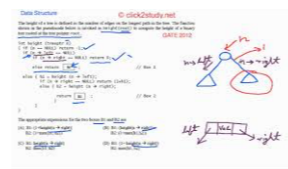

Results & implications

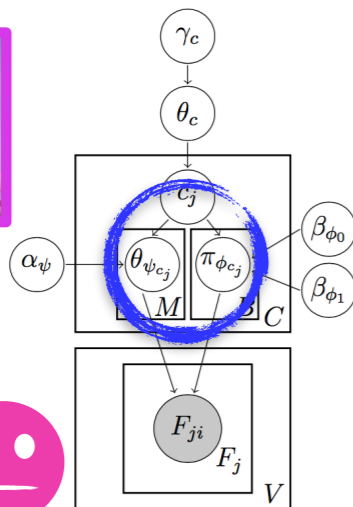

Verb classes

Verbs allow a variety of options for where their arguments appear ...

try

She **tried** to **melt** the ice.

It **tried that she **melted** the ice.*



seem

The penguin **seemed** to **climb** the hill.

It **seemed** that the penguin **climbed** the hill.



Verb classes

Verbs allow a variety of options for where their arguments appear and how they're interpreted.

doer_{melt}

try

doer_{tried}

She **tried** to **melt** the ice.

doer_{melted}

*It **tried** that she **melted** the ice.



seem

doer_{climb}

The penguin **seemed** to **climb** the hill.

doer_{climb}

It **seemed** that the penguin **climbed** the hill.



Verb classes

Verbs allow a variety of options for where their arguments appear and how they're interpreted.

*doer*_{melt}

try

*doer*_{tried}

She **tried** to **melt** the ice.

**It tried that she melted the ice.*



melt

*done-to*_{melted}

The ice **melted**.

seem

*doer*_{climb}

The penguin **seemed** to **climb** the hill.

It **seemed** that the penguin **climbed** the hill.



*doer*_{climbed}

The penguin **climbed**.

climb

Verb classes

Each verb has **certain linguistic patterns of behavior**, which are shared with other verbs in the same **verb class**.

want need

subject-control

*doer*_{melt}

try

*doer*_{tried}

She **tried** to **melt** the ice.

**It tried that she melted the ice.*

appear

subject-raising

seem

*doer*_{climb}

The penguin **seemed** to **climb** the hill.

It **seemed** that the penguin **climbed** the hill.

*done-to*_{melted}

The ice **melted**.

melt

unaccusative

break fall



*doer*_{climbed}

The penguin **climbed**.

climb

unergative

laugh dance

Verb classes

How do we tell how a **new verb** will behave?

want need

subject-control

*doer*_{melt}

try

*doer*_{tried}

She **tried** to **melt** the ice.

*It **tried** that she **melted** the ice.

*done-to*_{melted}

The ice **melted**.

melt

unaccusative

break fall



appear

subject-raising

seem

*doer*_{climb}

The penguin **seemed** to **climb** the hill.

It **seemed** that the penguin **climbed** the hill.



*doer*_{climbed}

The penguin **climbed**.

climb

unergative

laugh dance

Verb classes

We can recognize that it belongs to a specific **verb class**, and use that knowledge to predict its behavior.

want need

subject-control

*doer*_{melt}

try

*doer*_{tried}

She **tried** to **melt** the ice.

**It tried that she melted the ice.*



appear

subject-raising

seem

*doer*_{climb}

The penguin **seemed** to **climb** the hill.

It **seemed** that the penguin **climbed** the hill.

*done-to*_{melted}

The ice **melted**.

blick melt

unaccusative

break fall



*doer*_{climbed}

The penguin **climbed**.

climb

unergative

laugh dance

*done-to*_{blicked}

The water **blicked**.



Verb classes

This is what we think kids are doing, too.



*The water seemed to **blick**.*

want need

subject-control

*doer*_{melt}

try

*doer*_{tried}

She **tried** to **melt** the ice.

It **tried that she **melted** the ice.*



appear

subject-raising

seem

*doer*_{climb}

The penguin **seemed** to **climb** the hill.

It **seemed** that the penguin **climbed** the hill.

*done-to*_{melted}

The ice **melted**.

blick melt

unaccusative

break fall



*doer*_{climbed}

The penguin **climbed**.

climb

unergative

laugh dance

*done-to*_{blicked}

The water **blicked**.



Verb classes

Important developmental step:
Grouping verbs into useful **classes** based on their **behavior**.



melt
unaccusative
break fall

want need
subject-control
try

appear
subject-raising
seem

climb
unergative
laugh dance

So how might children do this?

And how can we test different proposals about how they might do this?

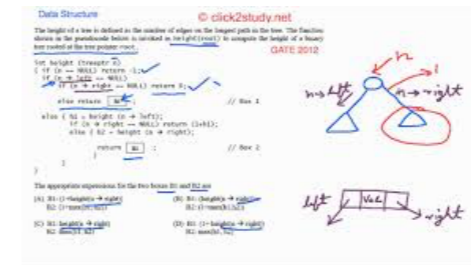

Today's plan

Computational modeling of language acquisition

Data Structure © click2study.net

The height of a tree is defined as the number of edges on the longest path to the leaf. The function below on the pseudocode below is used to compute the height of a binary tree rooted at the tree pointer root.

```
int height(struct tnode *root)
{
    if (!root) return 0;
    if (!root->left) return 1;
    if (!root->right) return 1;
    else return 1 + max(height(root->left), height(root->right));
}
// Rec 1
```

The appropriate expression for the tree below is: `1 + max(1, 1)`

(A) 1 + height of left (B) 1 + height of right (C) 1 + max(1, 1) (D) 1 + height of root

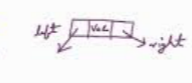
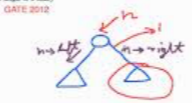

A brief overview

Language acquisition = Information processing task



Language acquisition = Information processing task

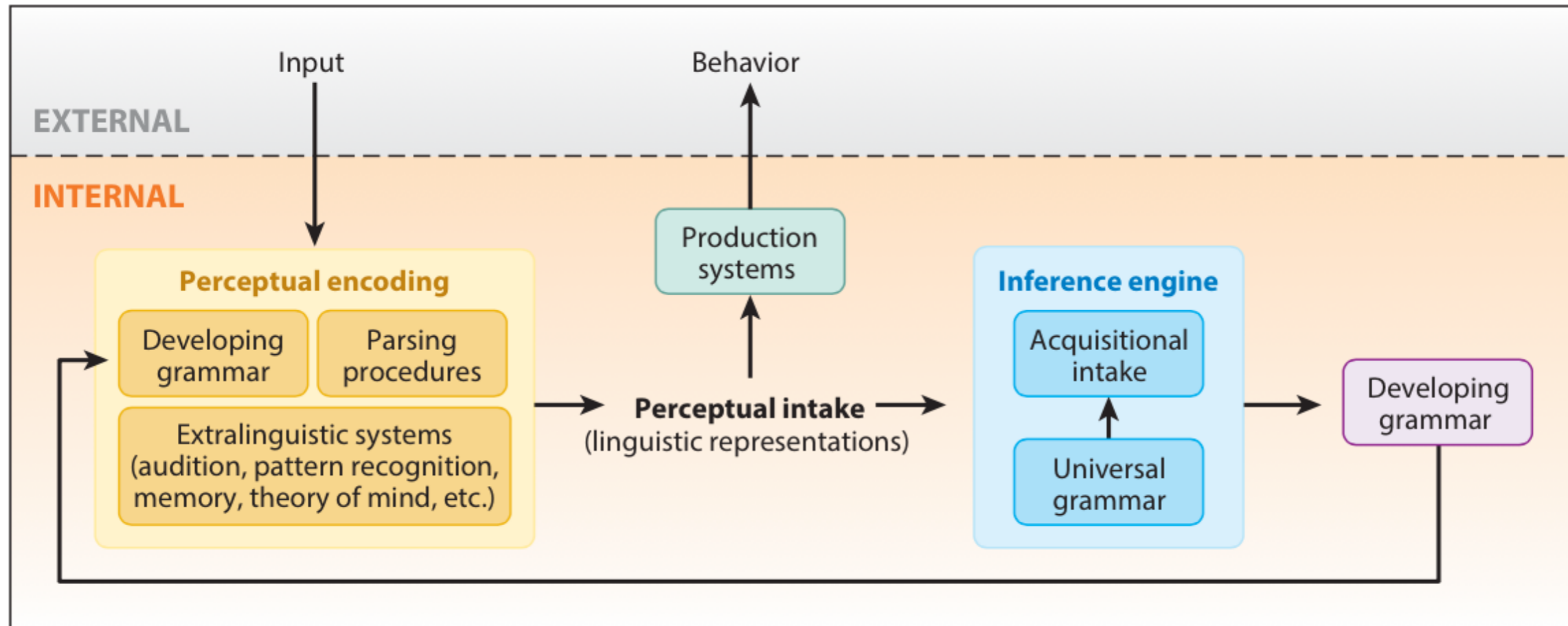

Lidz & Gagliardi 2015



A framework that makes components of the acquisition task more explicit.

A framework that makes components of the acquisition task more explicit.

Distinguishes between things external to the child that we can observe (**input signal**, **child's behavior**) vs. things internal to the child (everything else).

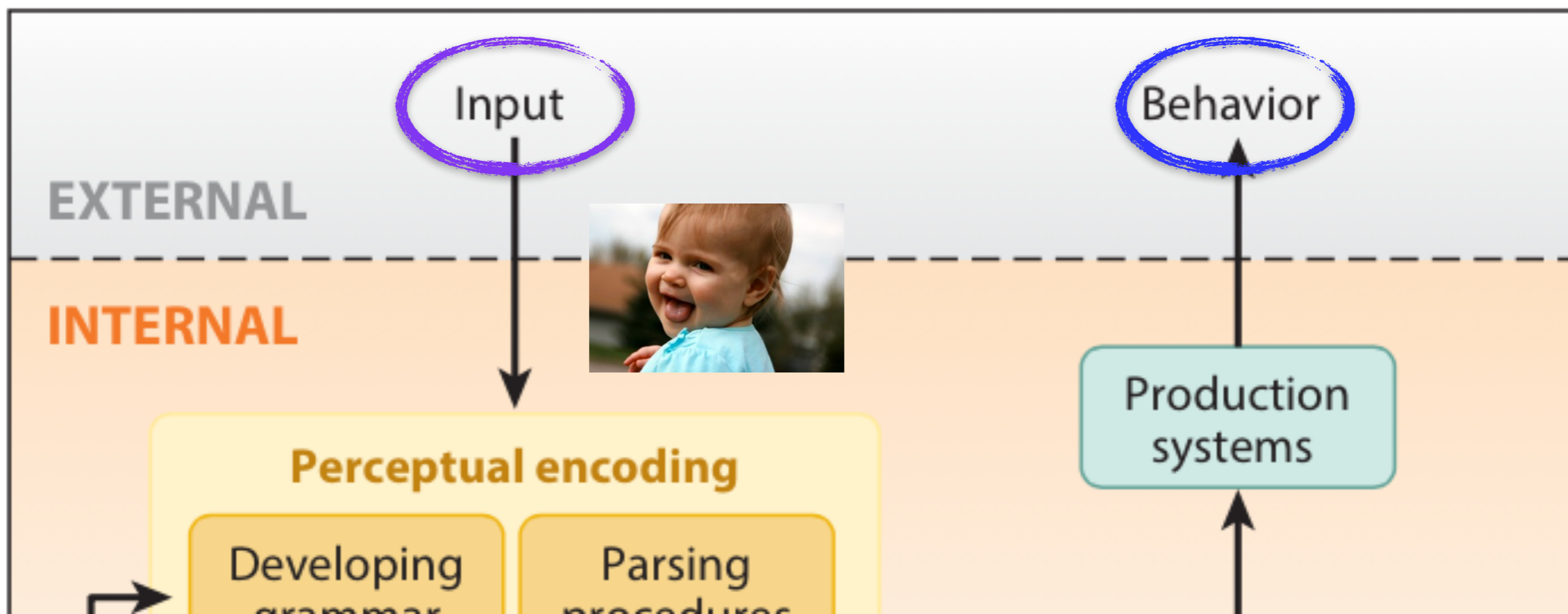

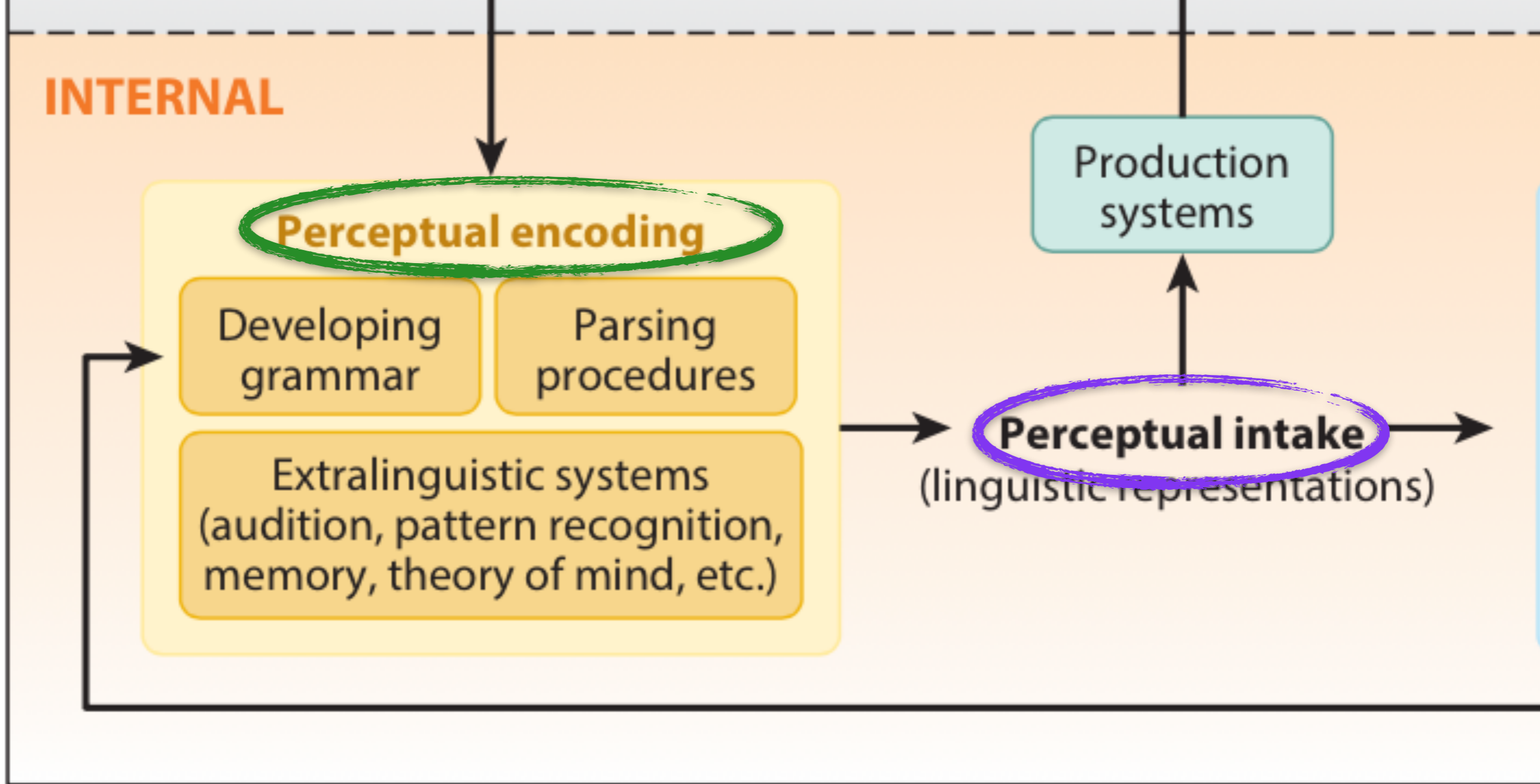

Lidz & Gagliardi 2015

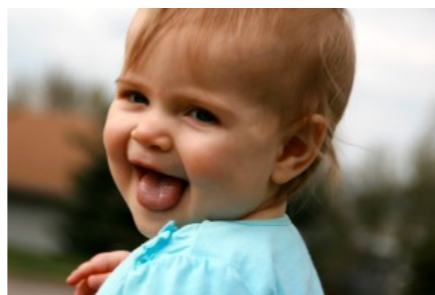

Perceptual encoding:

Turning the input signal into an internal linguistic representation = **perceptual intake**.

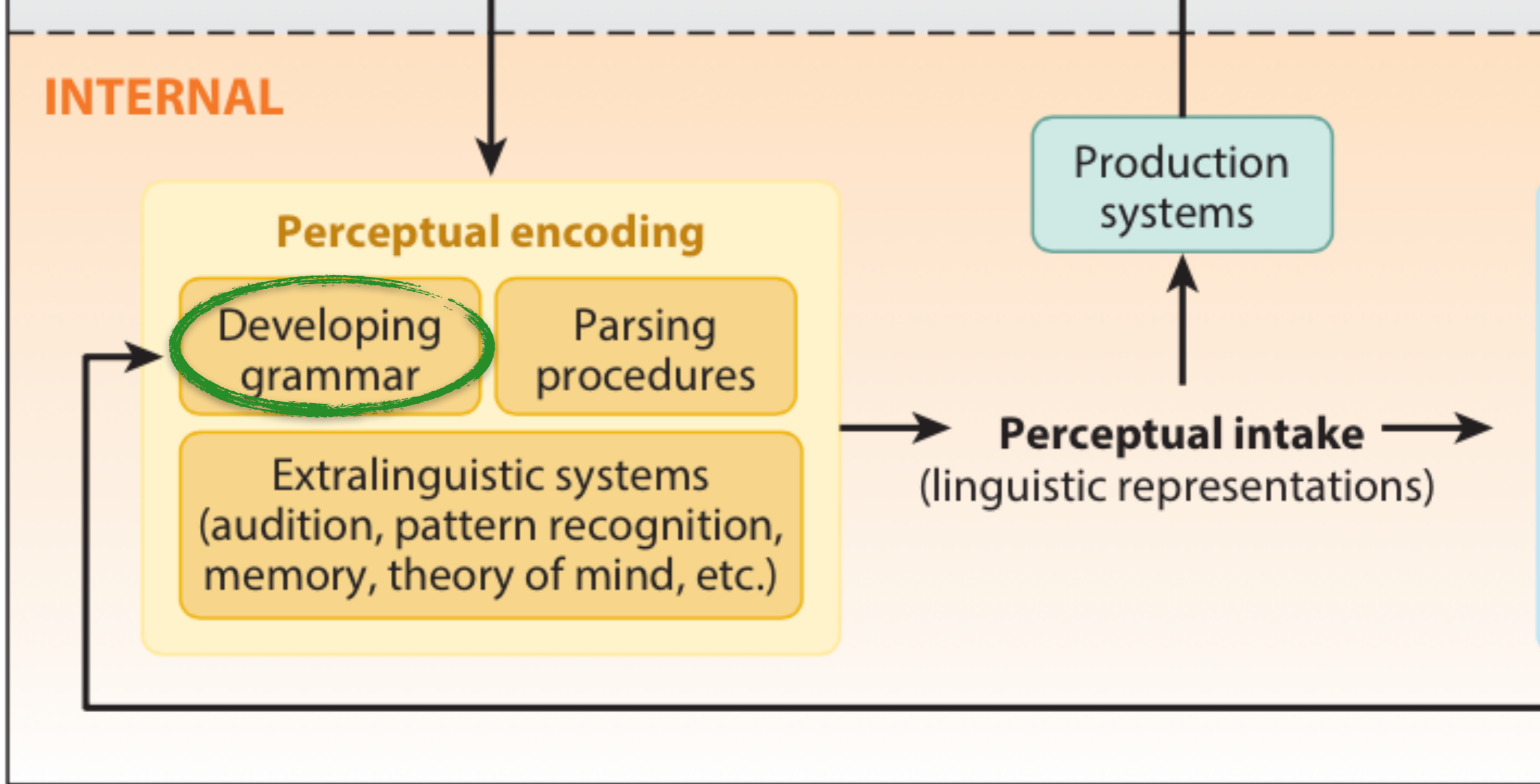

Lidz & Gagliardi 2015

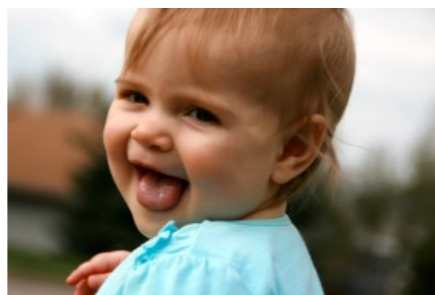

Perceptual encoding:
Involves **current grammar**

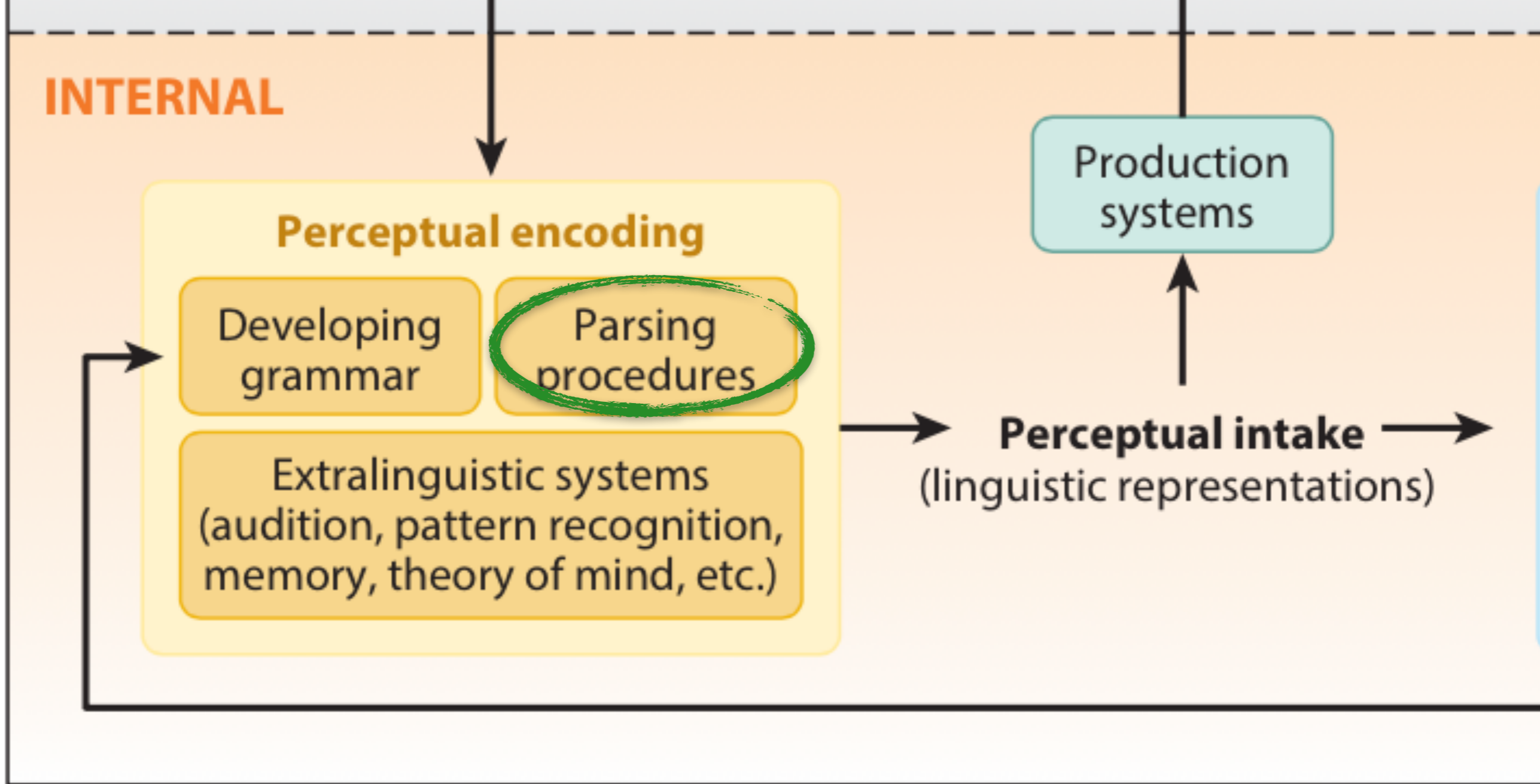

Lidz & Gagliardi 2015

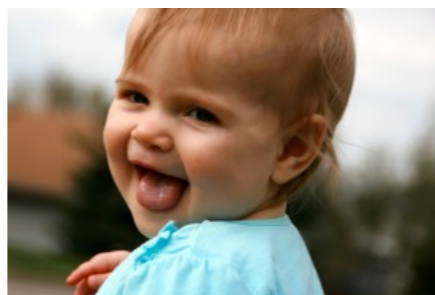

Perceptual encoding:

Involves current grammar being **deployed in real time to parse** the input

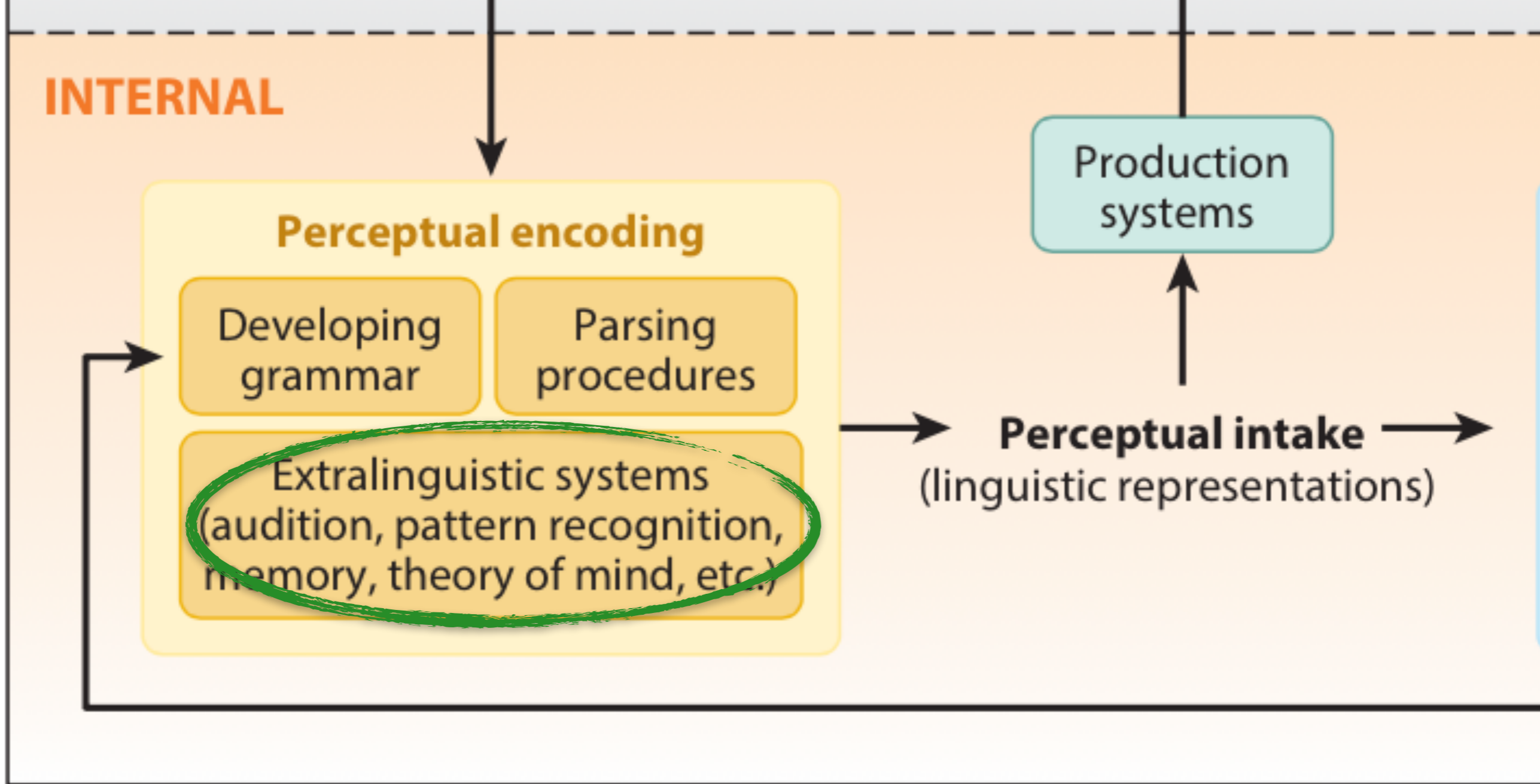

Lidz & Gagliardi 2015

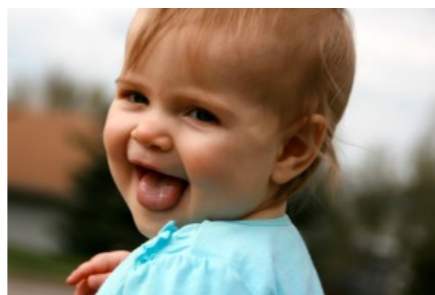

Perceptual encoding:

Involves current grammar being deployed in real time to parse the input, often drawing on **extralinguistic systems**

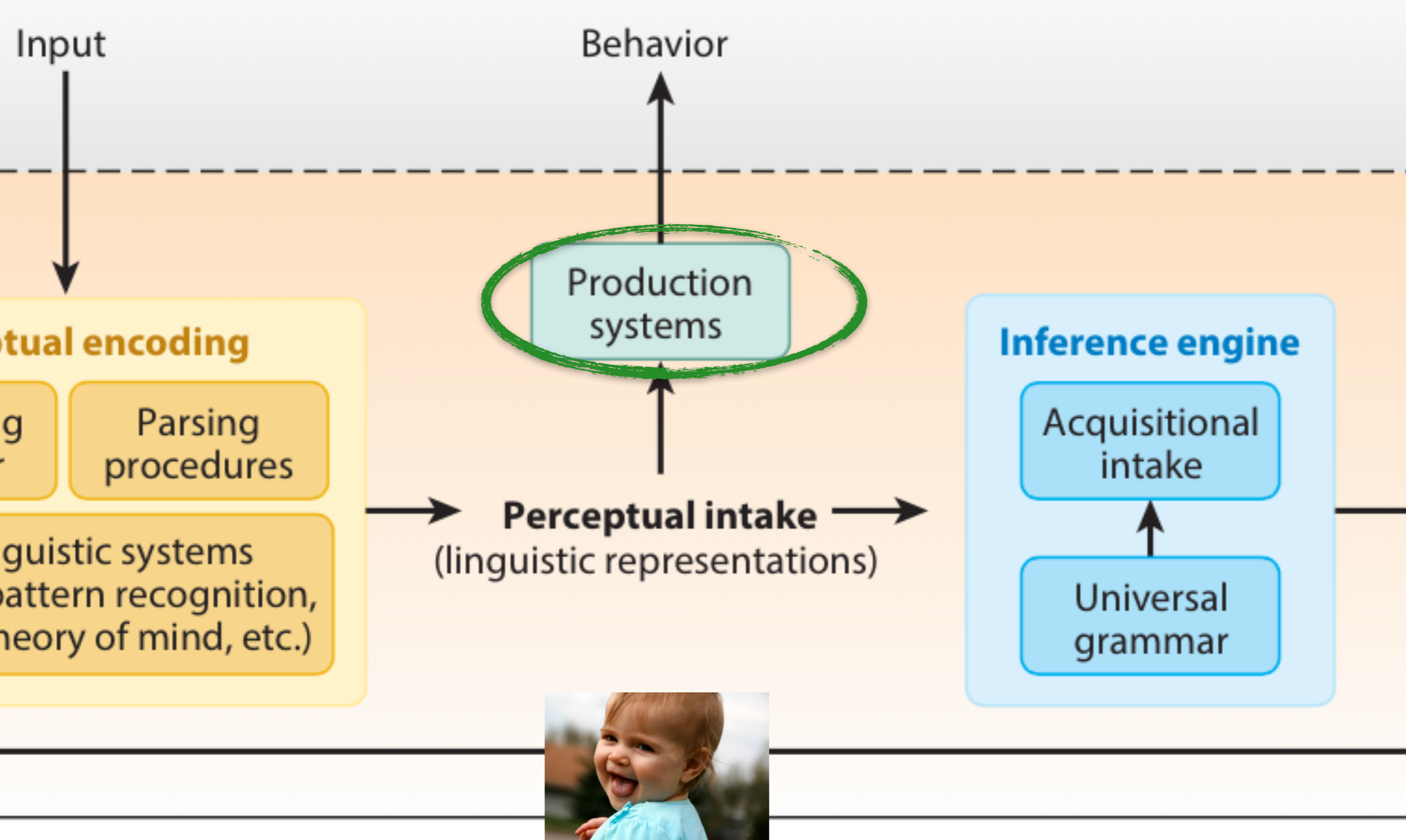

Generating observable **behavior**

Involves current linguistic representations being used by **production systems**.

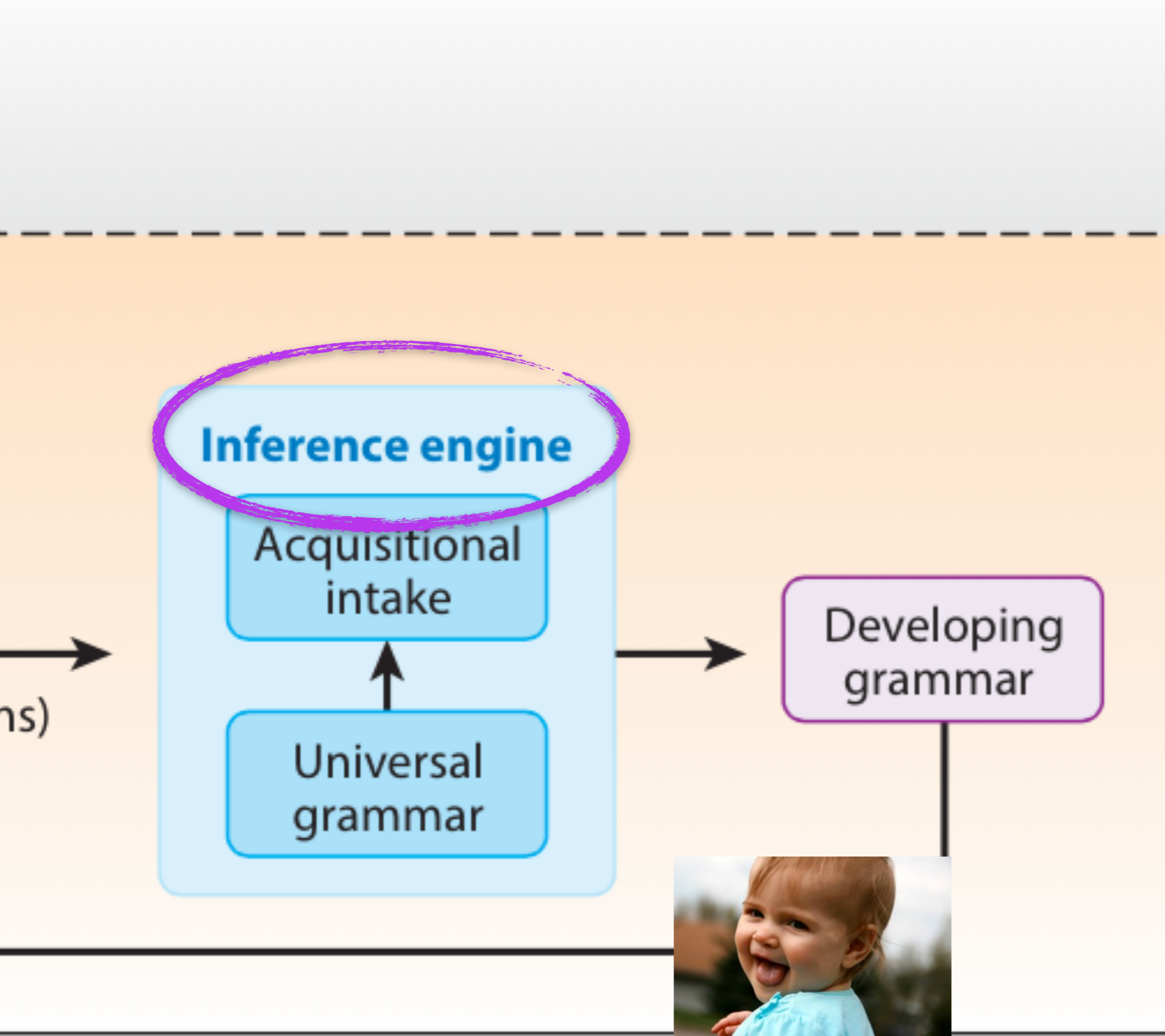

Doing inference

Generalization happens

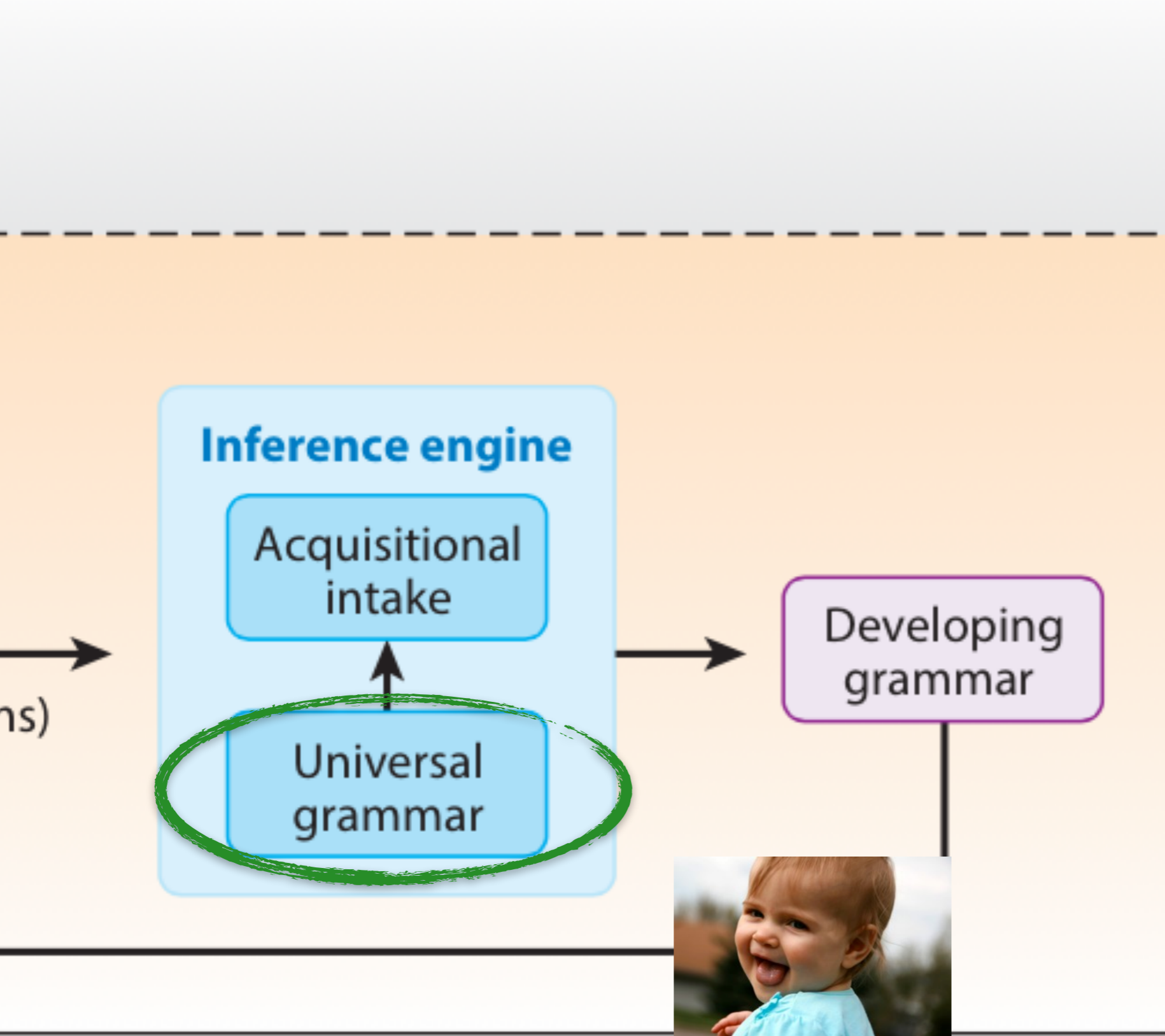

Doing inference

Generalization happens by using **existing learning biases**, (some of which may be innate and language-specific)

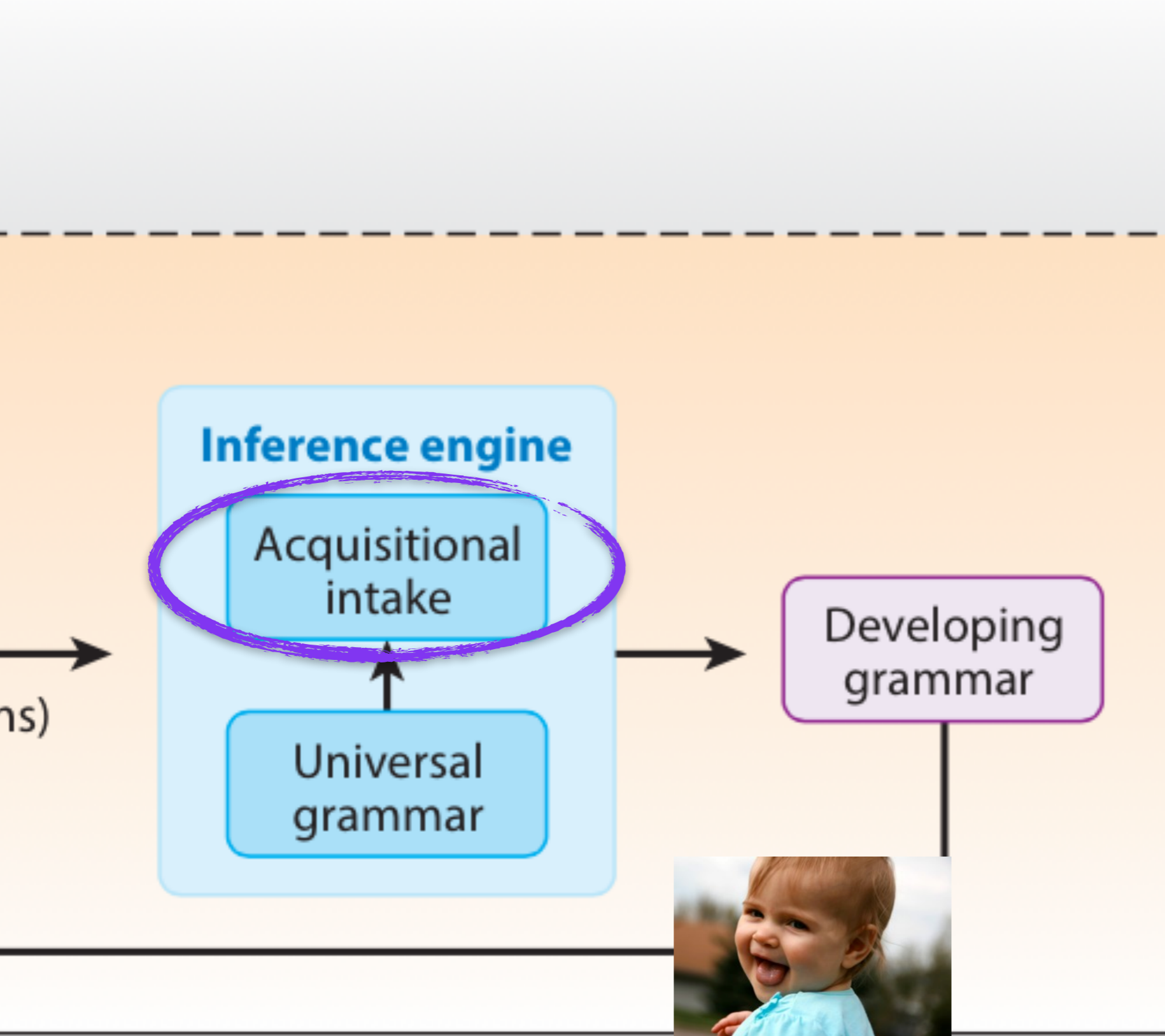

Doing inference

Generalization happens by using existing learning biases, (some of which may be innate and language-specific) operating over the **acquisitional intake** — what's perceived as relevant for acquisition

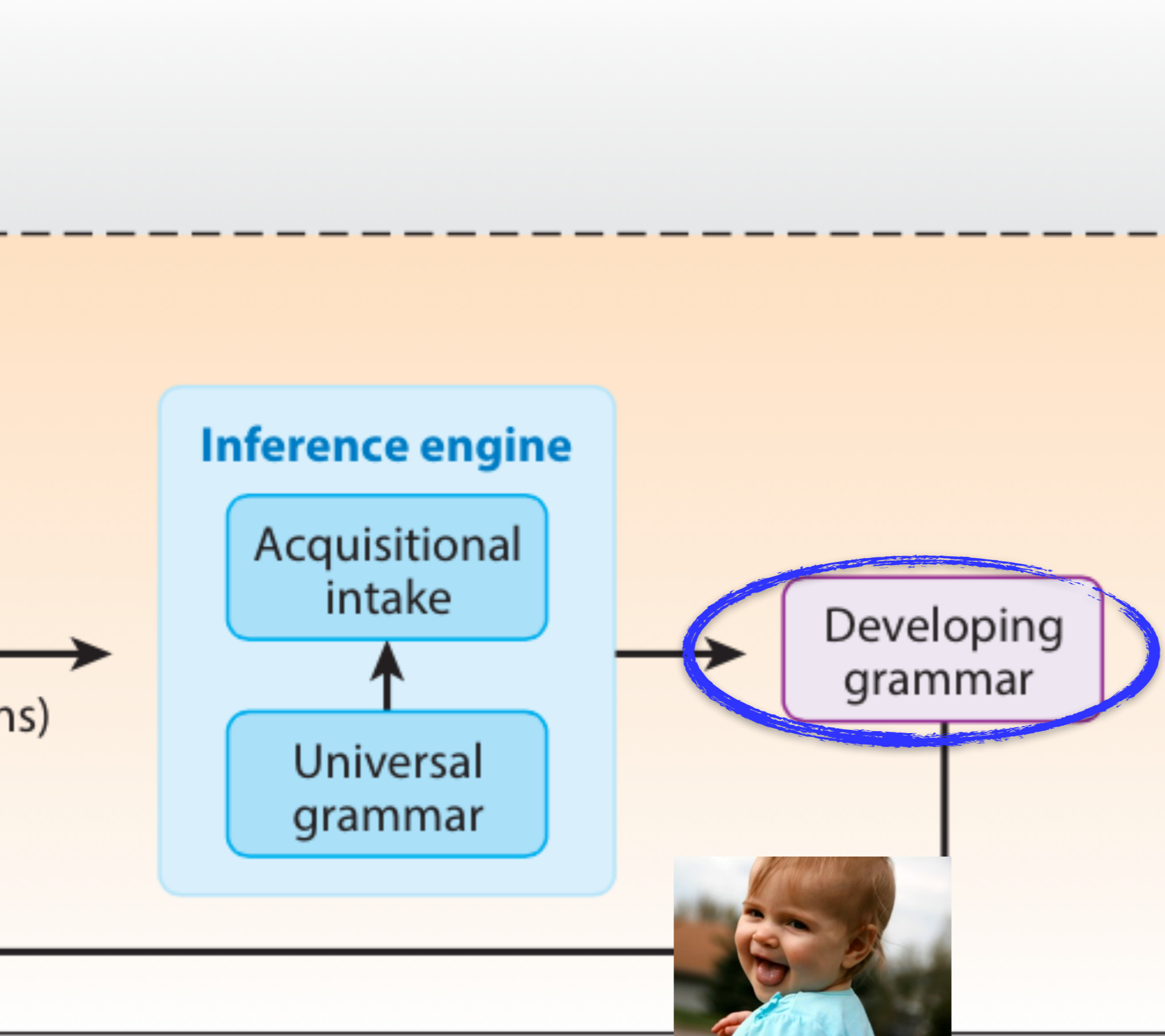

Doing inference

Generalization happens by using existing learning biases, (some of which may be innate and language-specific) operating over the acquisitional intake — what's perceived as relevant for acquisition to produce the most **up-to-date hypotheses** about linguistic knowledge

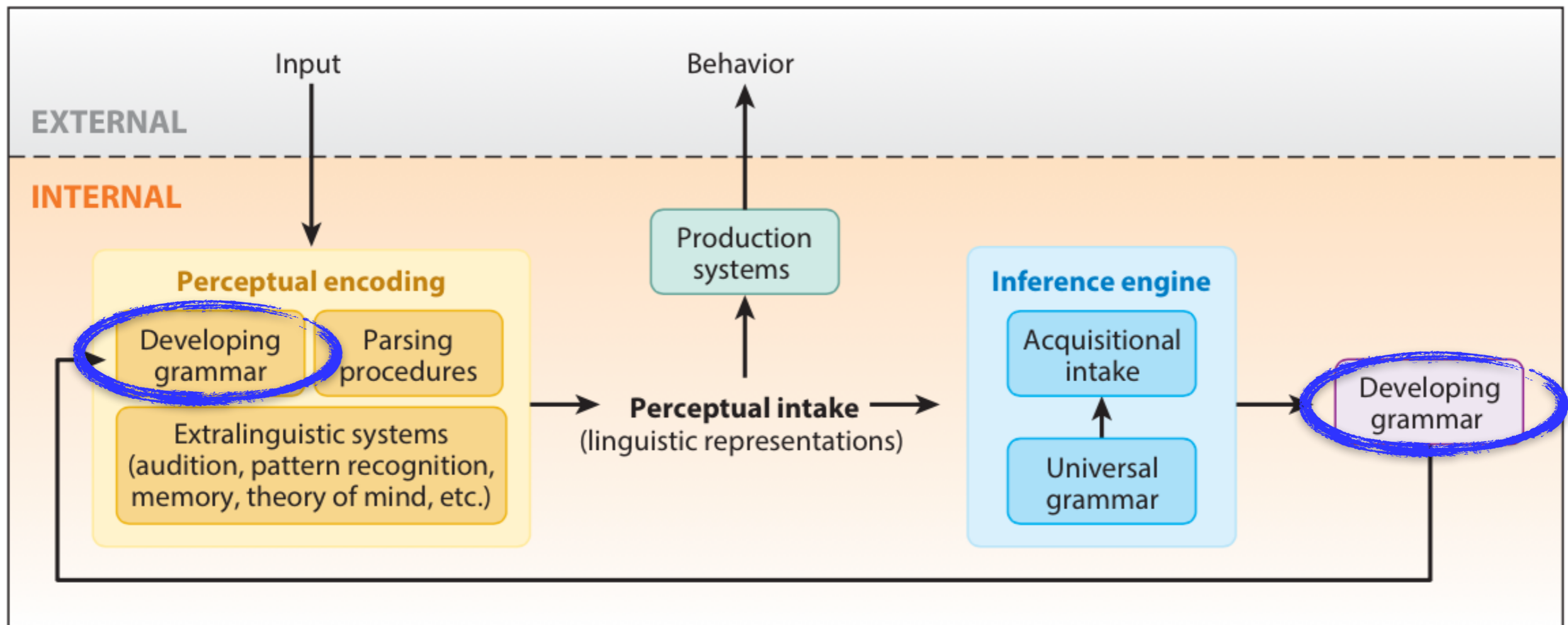

Lidz & Gagliardi 2015

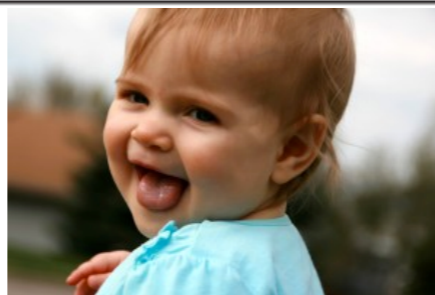

The current linguistic hypotheses are used in subsequent perceptual encoding

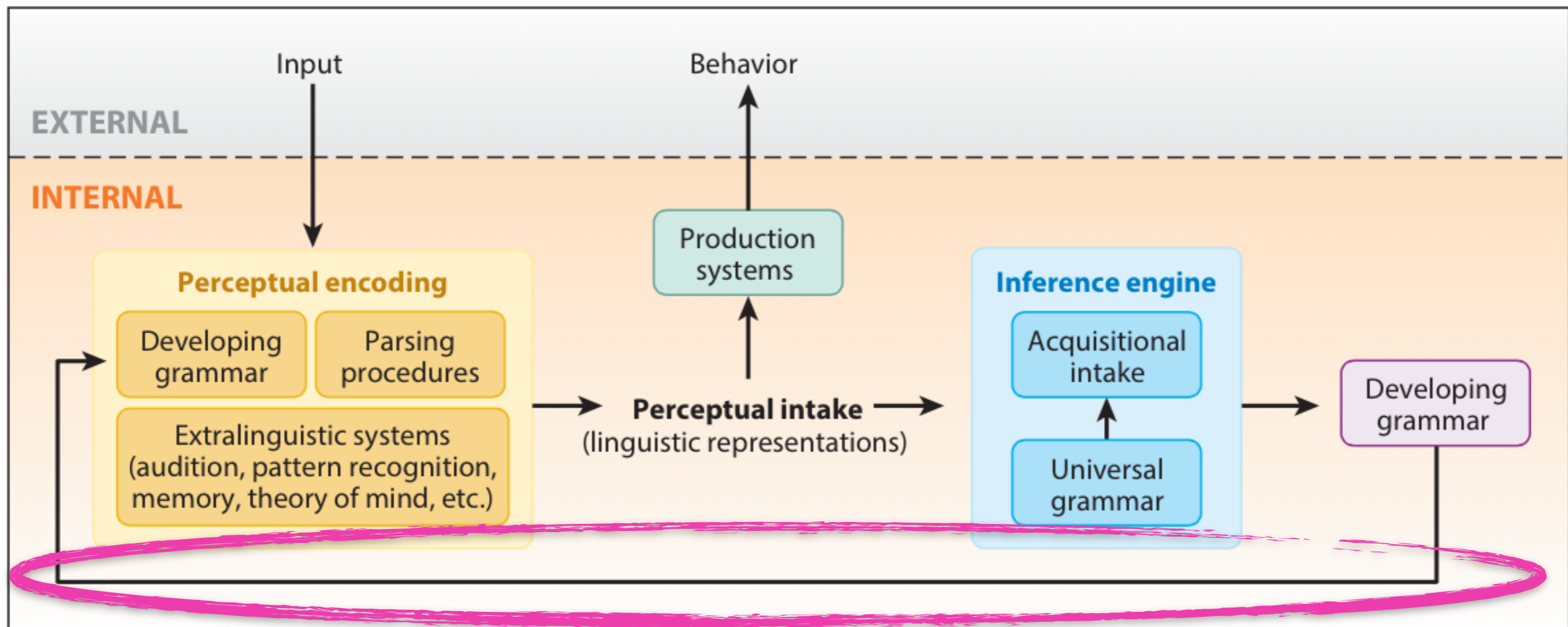

Lidz & Gagliardi 2015

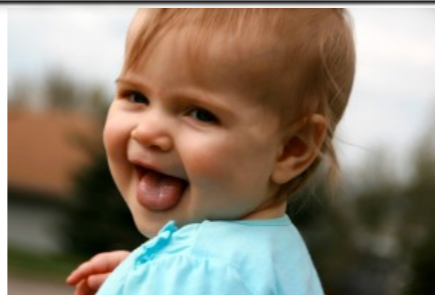

This whole process happens over and over again throughout the **learning period**

This is language acquisition

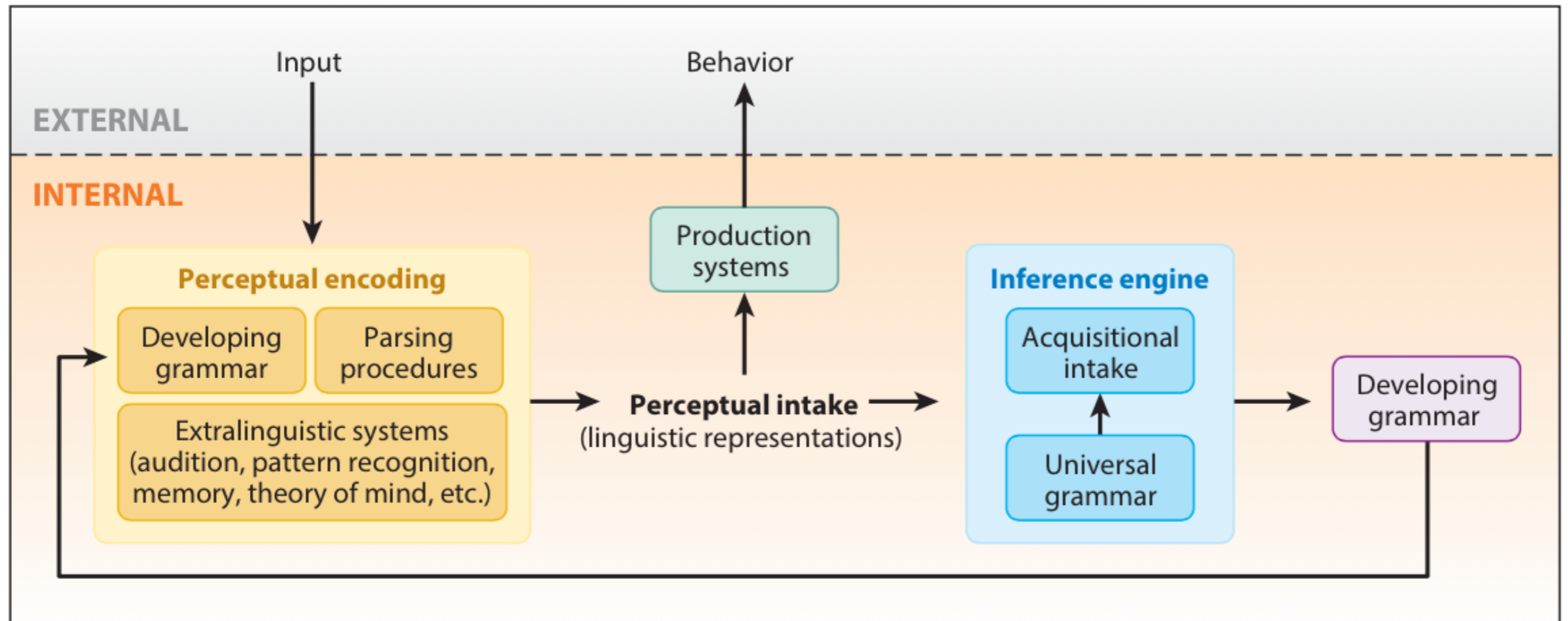

Lidz & Gagliardi 2015

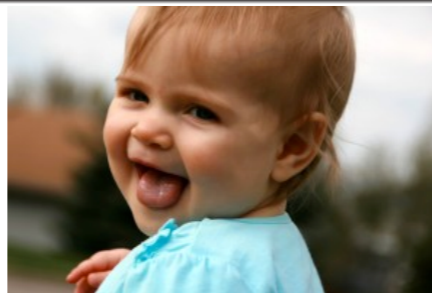

Corpus Experimental
Theoretical Computational

An informative computational model of language acquisition captures these important pieces in an **empirically-grounded** way.

This is language acquisition

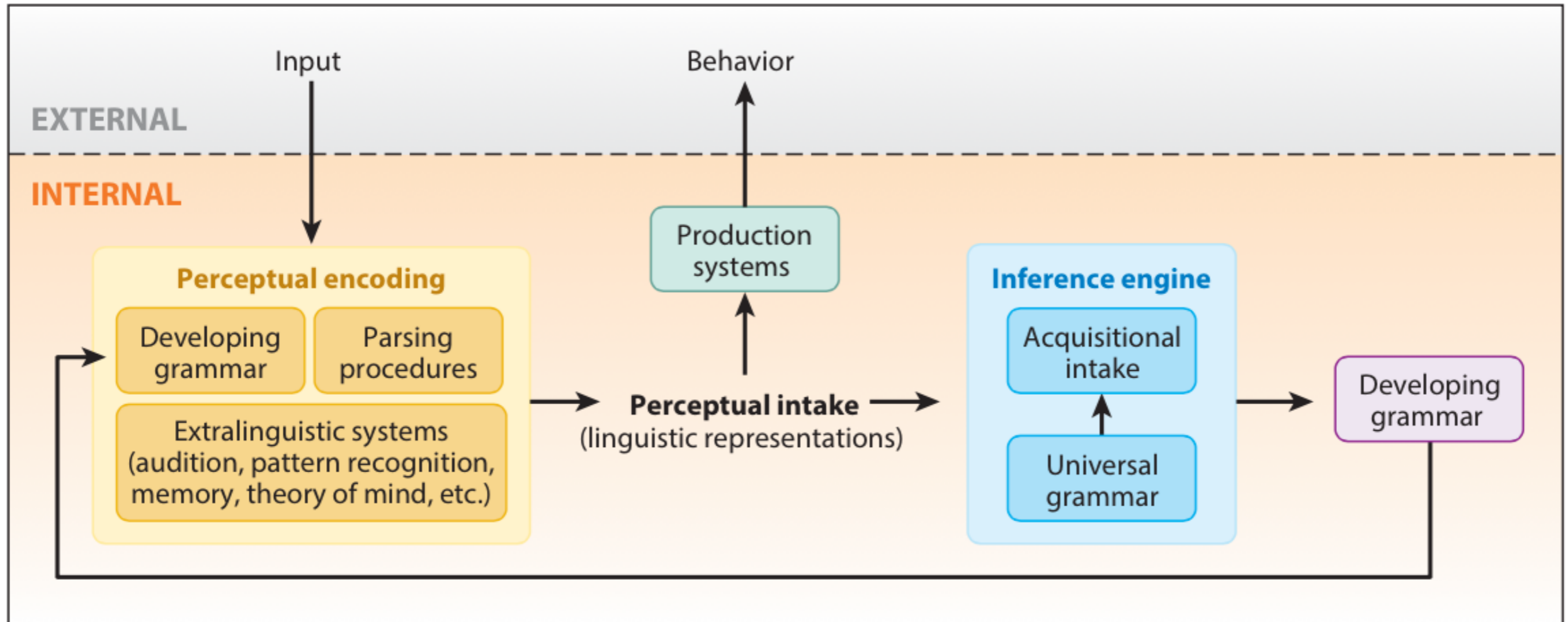

Lidz & Gagliardi 2015



Informative computational models =
informative about **the learning strategies children use**

Learning strategies children use

A successful learning strategy is an existence proof that linguistic knowledge is attainable using **the knowledge, learning biases, and capabilities comprising that strategy.**

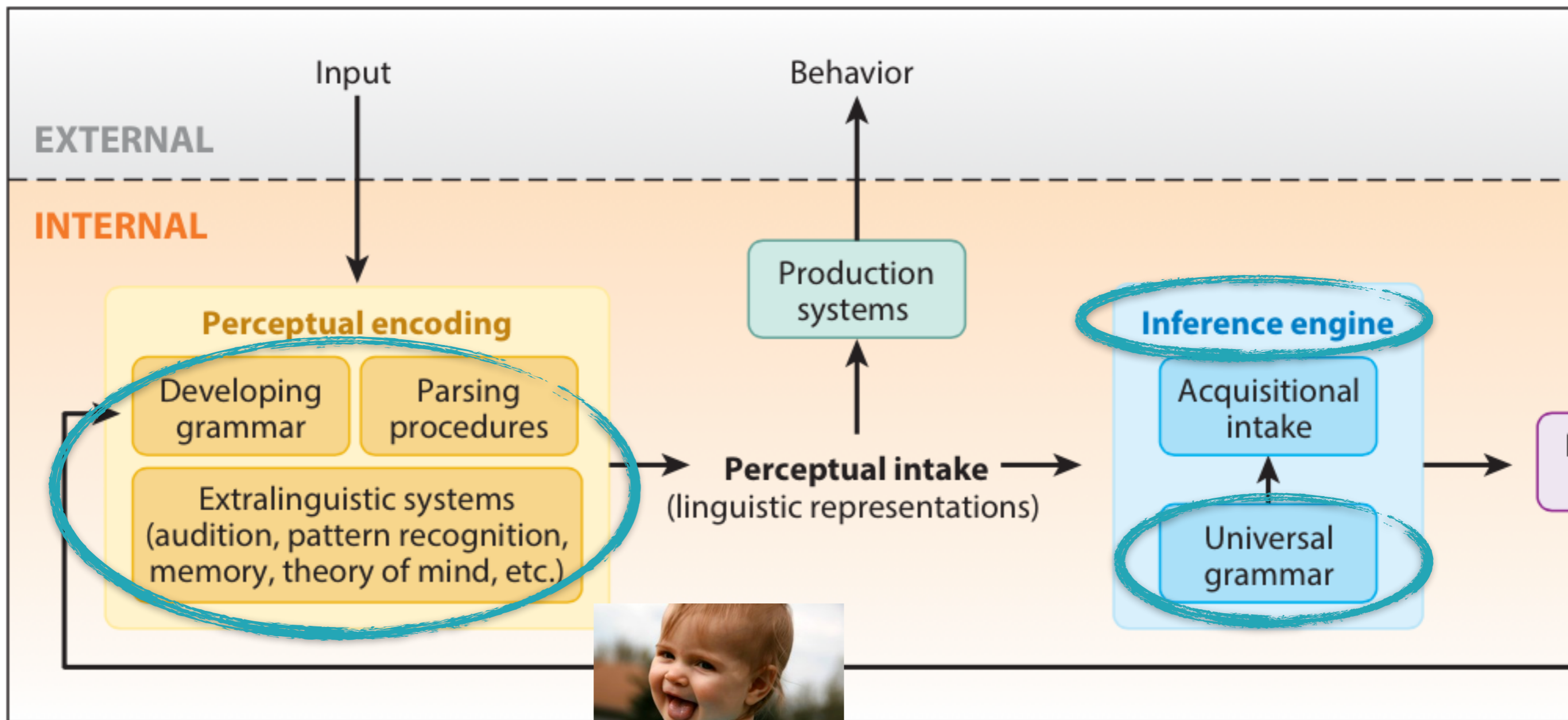

Learning strategies children use

This is what we want to evaluate with computational modeling.

The penguin tried to climb.



The ice seemed to melt.

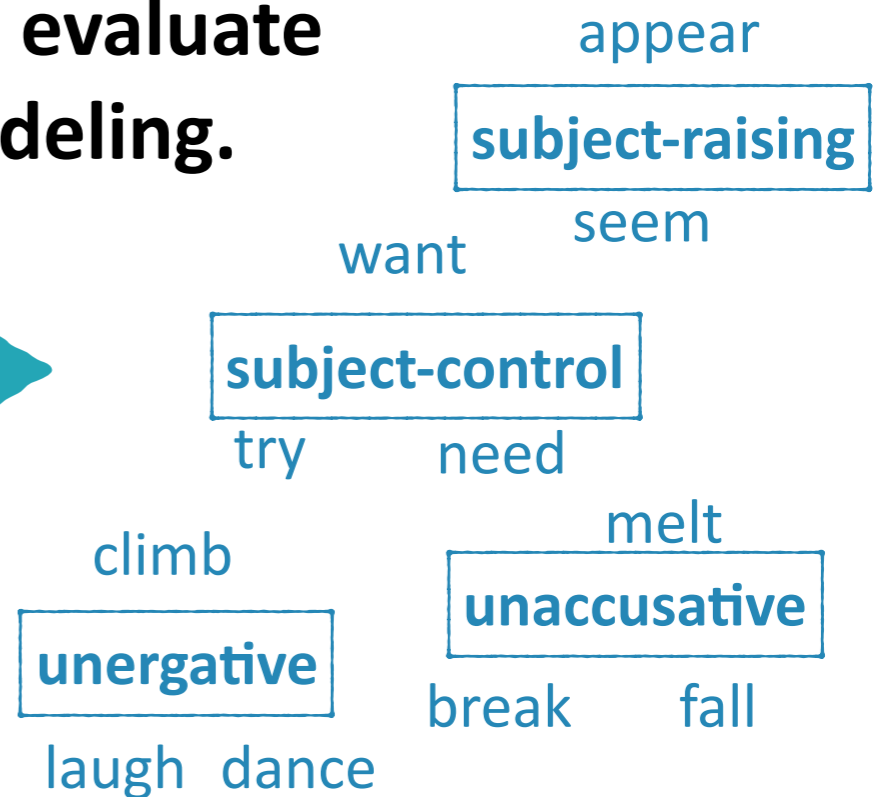

Today's plan

Computational modeling

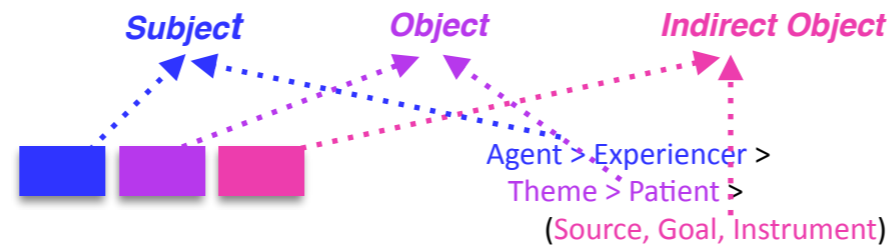

Information available and how to use it

Information available

The penguin tried
to climb.



The ice seemed
to melt.



want
subject-control

try need

climb

unergative

laugh dance

appear
subject-raising

seem

melt

unaccusative

break fall

Syntactic cues

Syntactic frame

Children are very adept at using **syntactic bootstrapping** to learn useful generalizations about how verbs behave (e.g., Fisher et al. 2010, Gutman et al. 2015, Harrigan et al. 2016).

Information available



The ice seemed to melt.



Syntactic cues

Syntactic frame

The penguin **tried** to climb.

NP _____ S_{nonfinite} -surface morphology
NP _____+past S_{nonfinite} +surface morphology

Information available



Syntactic frame

NP _____ S_{nonfinite} -surfmorph
NP _____+past S_{nonfinite} +surfmorph

Conceptual cues Animacy

+animate



The penguin tried
to climb.

-animate



The ice seemed
to melt.

Information available



climb
unergative
 laugh dance

melt
unaccusative
 break fall

Syntactic frame

NP _____ S_{nonfinite} -surfmorph

NP _____+past S_{nonfinite} +surfmorph

Conceptual cues

Animacy

+animate
 The penguin tried
 to climb.



-animate
 The ice seemed
 to melt.



Becker 2009, Kirby 2009, Kirby 2010,
 Becker 2014, Becker 2015, Hartshorne et al. 2015

appear seem

subject-raising

ask beg

object-raising

It's useful:

It can distinguish verb behaviors like
 raising vs. control verbs, and psych
 object-experiencer verbs.

try

subject-control

want

need

object-control

believe

surprise

annoy

psych object-experiencer

worry

Information available



want
subject-control

try need

climb

unergative

laugh dance

appear
subject-raising

seem

melt

unaccusative

break fall

Syntactic frame

NP _____ S_{nonfinite} -surfmorph

NP _____+past S_{nonfinite} +surfmorph

Conceptual cues

Animacy

+animate

The penguin tried
to climb.



-animate

The ice seemed
to melt.



Becker 2009, Kirby 2009, Kirby 2010,
Becker 2014, Becker 2015, Hartshorne et al. 2015

Children use it:

Young children have been shown to use
this cue in experimental studies.



Information available

The penguin tried
to climb.

The ice seemed
to melt.



want
subject-control

try need

climb

unergative

laugh dance

appear
subject-raising

seem

melt

unaccusative

break fall

Syntactic frame

NP ____ S_{nonfinite} -surfmorph

NP ____+past S_{nonfinite} +surfmorph

Animacy

+animate

The penguin tried
to climb.



-animate

The ice seemed
to melt.



Conceptual cues

Thematic roles

Children could use them:

Thematic roles that indicate event participant roles are salient to very young children.

(<10 months: Gordon 2003; 6 months: Hamlin, Wynn, & Bloom 2007, Hamlin, Wynn, Bloom, & Mahajan 2011)



doer = Agent



done-to = Patient



Information available

Conceptual cues + Syntactic-semantic knowledge
Thematic roles and how to use them

Syntax

She melted the ice with a blow dryer.

Subject

Object

Indirect Object



Syntactic frame

NP ____ S_{nonfinite} -surfmorph

NP ____+past S_{nonfinite} +surfmorph

Animacy

+animate

The penguin tried
to climb.



-animate

The ice seemed
to melt.



How do we get from here to here?



Thematic roles Agent, Experiencer, Patient, Theme, Goal, Source, Instrument...

Information available

Conceptual cues + Syntactic-semantic knowledge
Thematic roles and how to use them

Syntax

She melted the ice with a blow dryer.

Subject

Object

Indirect Object



Syntactic frame

NP ____ S_{nonfinite} -surfmorph

NP ____+past S_{nonfinite} +surfmorph

Animacy

+animate

The penguin tried to climb.



-animate

The ice seemed to melt.



Theories of prior knowledge

Intermediate representations

Thematic roles map to one of three categories.

The **U**niformity of **T**heta **A**ssignment **H**ypothesis

Baker 1988, Baker 1997, Dowty 1991, Fillmore 1968, Grimshaw 1990, Jackendoff 1987, Perlmutter & Postal 1984, Speas 1990

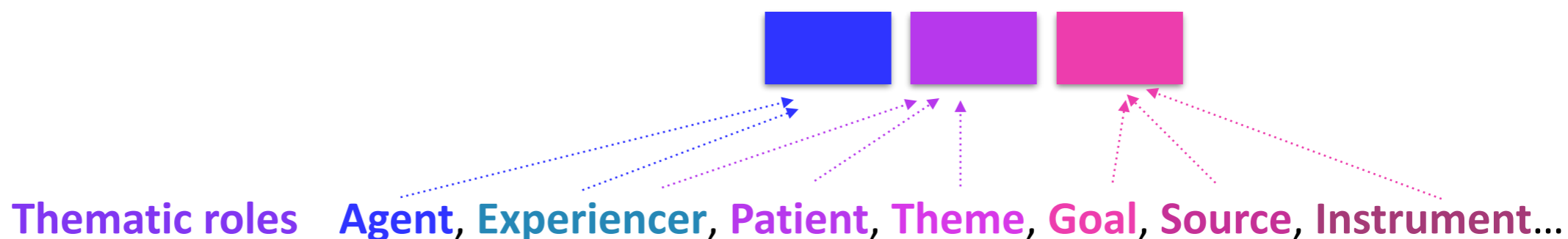

Information available

Conceptual cues + Syntactic-semantic knowledge
Thematic roles and how to use them



Syntax

She melted the ice with a blow dryer.

Subject

Object

Indirect Object

Syntactic frame

NP ____ S_{nonfinite} -surfmorph

NP ____+past S_{nonfinite} +surfmorph

Animacy

+animate

The penguin tried to climb.



-animate

The ice seemed to melt.



Mapping to Syntax

Theories of prior knowledge

Intermediate representations

These categories map to syntactic positions.

Thematic roles map to one of three categories.

UTAH

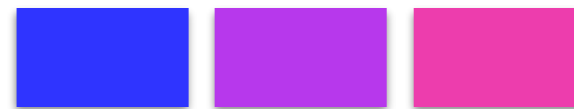

Thematic roles Agent, Experiencer, Patient, Theme, Goal, Source, Instrument...

Information available

Conceptual cues + Syntactic-semantic knowledge
Thematic roles and how to use them

Syntax

She melted the ice with a blow dryer.

Subject

Object

Indirect Object



Syntactic frame

NP _____ S_{nonfinite} -surfmorph

NP _____+past S_{nonfinite} +surfmorph

Animacy

+animate

The penguin tried to climb.



-animate

The ice seemed to melt.



Mapping to Syntax

Theories of prior knowledge

Intermediate representations

UTAH

Thematic roles are ordered with respect to each other.

The (relativized) UTAH

Larson 1988, Larson 1990

Agent > Experiencer >

Theme > Patient >

(Source, Goal, Instrument)

Thematic roles Agent, Experiencer, Patient, Theme, Goal, Source, Instrument...

Information available

Conceptual cues + Syntactic-semantic knowledge
 Thematic roles and how to use them



Syntax

She melted the ice with a blow dryer.

Subject

Object

Indirect Object

Syntactic frame

NP _____ S_{nonfinite} -surfmorph

NP _____+past S_{nonfinite} +surfmorph

Animacy

+animate

The penguin tried to climb.



-animate

The ice seemed to melt.



Mapping to Syntax

Theories of prior knowledge

Intermediate representations

Whichever ones are present map in order to syntactic positions.

UTAH

rUTAH

Agent > Experiencer >

Theme > Patient >

(Source, Goal, Instrument)

Thematic roles Agent, Experiencer, Patient, Theme, Goal, Source, Instrument...

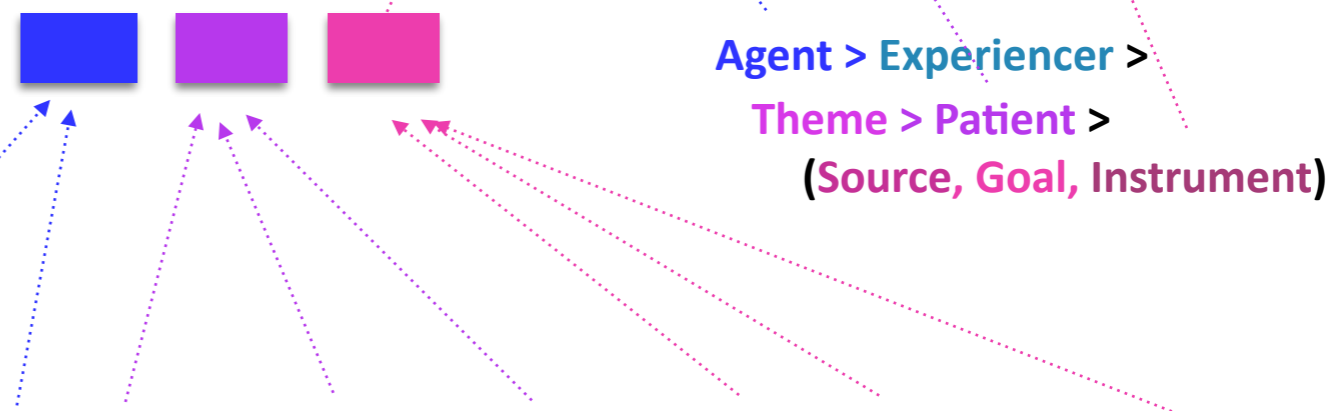

Information available

Conceptual cues + Syntactic-semantic knowledge
Thematic roles and how to use them

Syntax

She melted the ice with a blow dryer.

Subject

Object

Indirect Object



Syntactic frame

NP _____ S_{nonfinite} -surfmorph

NP _____+past S_{nonfinite} +surfmorph

Animacy

+animate

The penguin tried to climb.



-animate

The ice seemed to melt.



Mapping to Syntax

Theories of prior knowledge

Intermediate representations

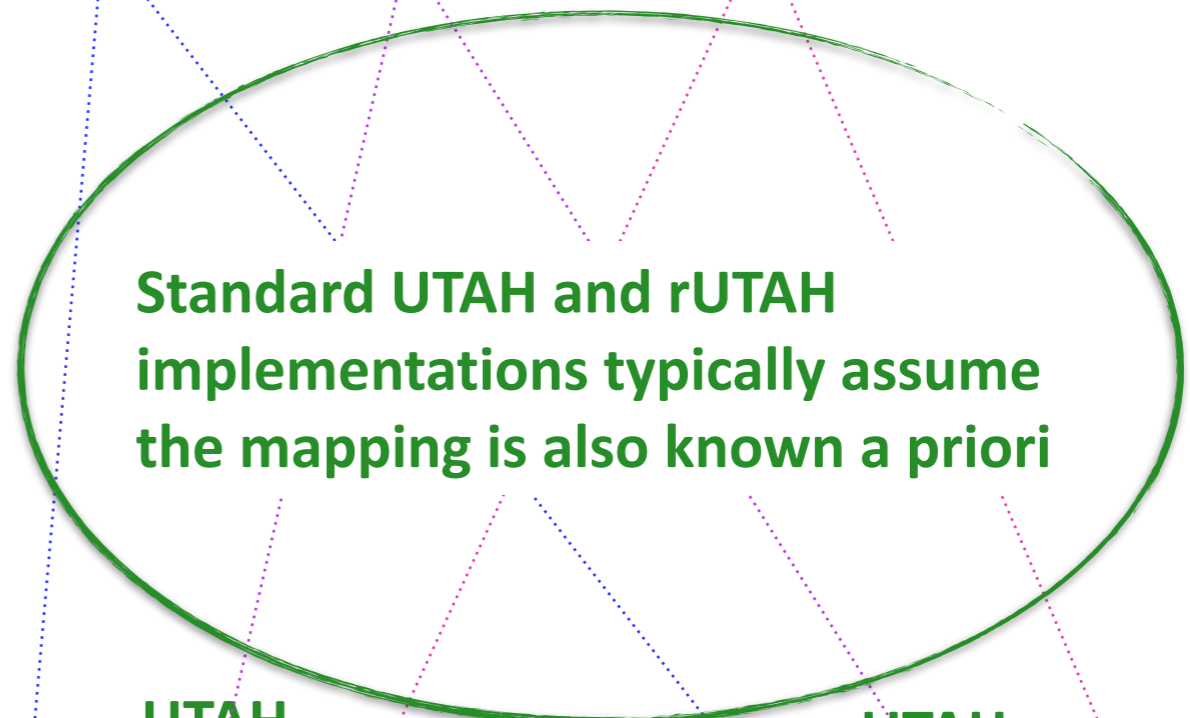

UTAH

rUTAH

Agent > Experiencer >
Theme > Patient >
(Source, Goal, Instrument)

Thematic roles Agent, Experiencer, Patient, Theme, Goal, Source, Instrument...

Information available

Conceptual cues + Syntactic-semantic knowledge
Thematic roles and how to use them

Syntax

She melted the ice with a blow dryer.

Subject

Object

Indirect Object



Syntactic frame

NP _____ S_{nonfinite} -surfmorph

NP _____+past S_{nonfinite} +surfmorph

But these are separate components

Mapping to Syntax

Animacy

+animate

The penguin tried to climb.



Theories of prior knowledge

-animate

The ice seemed to melt.



Intermediate representations

UTAH

rUTAH

Agent > Experiencer >
Theme > Patient >
(Source, Goal, Instrument)

Thematic roles Agent, Experiencer, Patient, Theme, Goal, Source, Instrument...

Information available

Conceptual cues + Syntactic-semantic knowledge
 Thematic roles and how to use them

Syntax

She melted the ice with a blow dryer.

Subject

Object

Indirect Object



Syntactic frame

NP _____ S_{nonfinite} -surfmorph

NP _____+past S_{nonfinite} +surfmorph

Whether children expect a mapping a priori impacts how they perceive the intake for acquisition

Mapping to Syntax

Theories of prior knowledge

Animacy

+animate

The penguin tried to climb.



-animate

The ice seemed to melt.



Intermediate representations

UTAH

rUTAH

Agent > Experiencer >
 Theme > Patient >
 (Source, Goal, Instrument)

Thematic roles Agent, Experiencer, Patient, Theme, Goal, Source, Instrument...

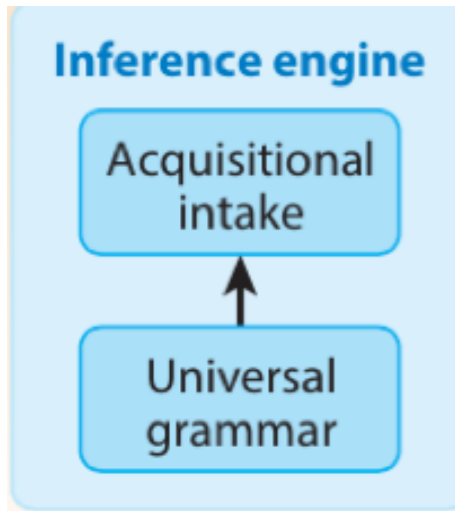

Information available

+expect a mapping

Salient when mapping doesn't hold:
Interpreted as movement



Syntax

The ice was melted by the girl.

Subject

Indirect Object

done-to

doer

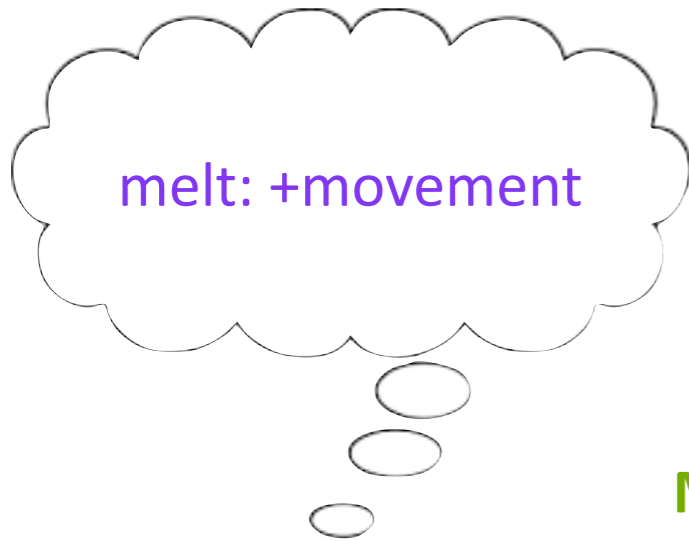

Mapping to Syntax

Theories of prior knowledge

Unexpected by UTAH

Intermediate representations

UTAH

rUTAH

Agent > Experiencer >
Theme > Patient >
(Source, Goal, Instrument)



Thematic roles Agent, Experiencer, Patient, Theme, Goal, Source, Instrument...

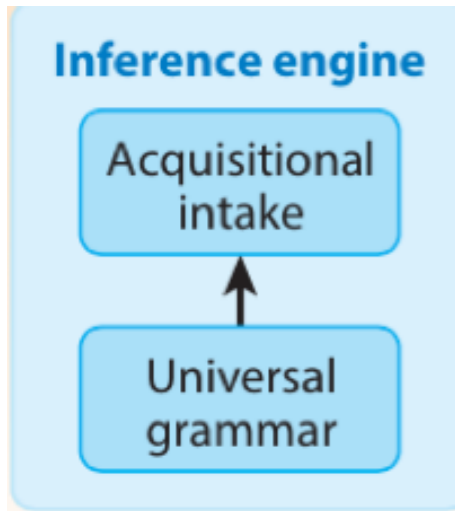

Information available

+expect a mapping

Salient when mapping doesn't hold:
Interpreted as movement

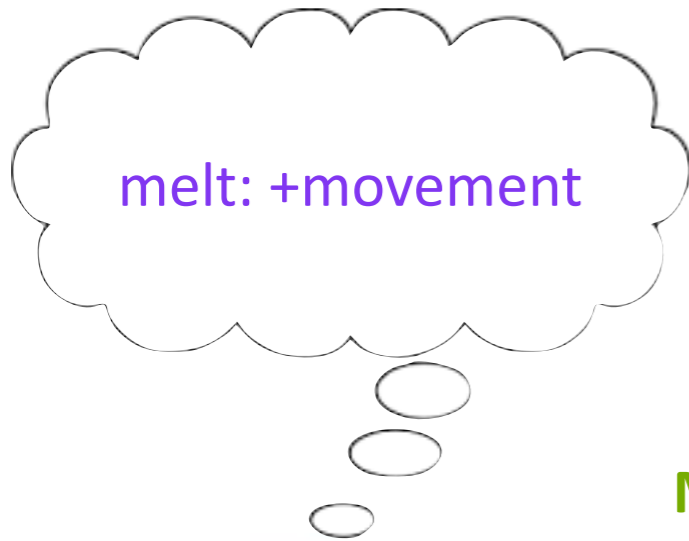

Syntax

The ice was melted by the girl.

Subject

Indirect Object

2nd highest

Highest



Mapping to Syntax

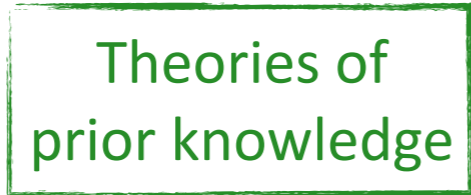

Intermediate representations

UTAH

rUTAH



Agent > Experiencer >

Theme > Patient >

(Source, Goal, Instrument)

Thematic roles Agent, Experiencer, Patient, Theme, Goal, Source, Instrument...



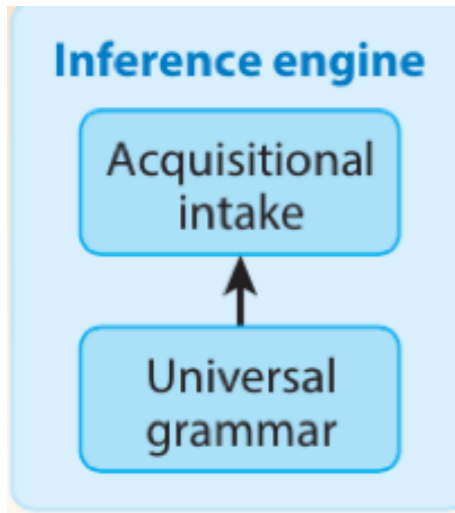

Information available

-expect a mapping

Children track grammatical positions of intermediate representations



Syntax

The ice was **melted** by the girl.

Subject

Indirect Object

done-to

doer

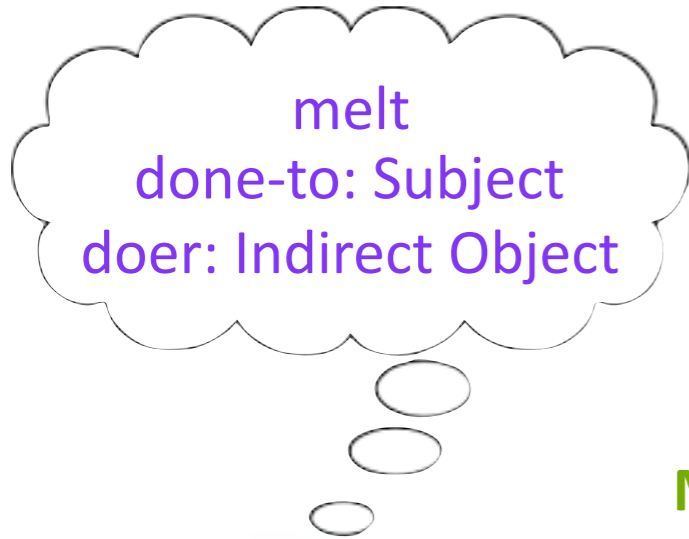

Mapping to Syntax

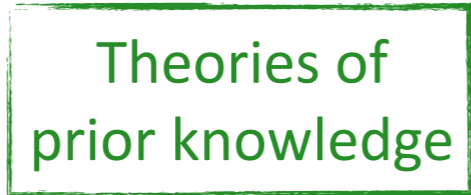

Intermediate representations

UTAH

rUTAH



Agent > Experiencer >
Theme > Patient >
(Source, Goal, Instrument)

Thematic roles Agent, Experiencer, Patient, Theme, Goal, Source, Instrument...



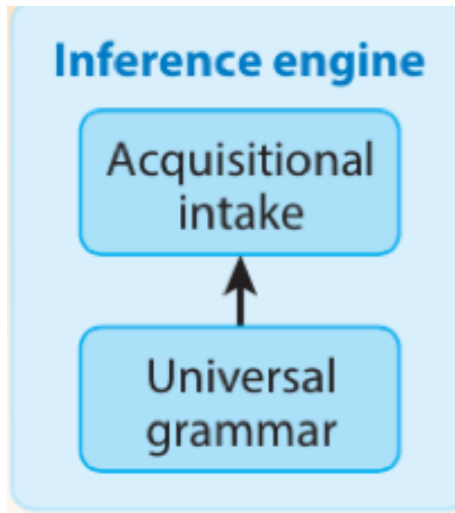

Information available

-expect a mapping

Children track grammatical positions of intermediate representations

Syntax

The ice was **melted** by the girl.

Subject

Indirect Object

2nd highest

Highest



Mapping to Syntax

Theories of prior knowledge

Intermediate representations

UTAH

rUTAH

Agent > Experiencer >

Theme > Patient >

(Source, Goal, Instrument)

Thematic roles Agent, Experiencer, Patient, Theme, Goal, Source, Instrument...



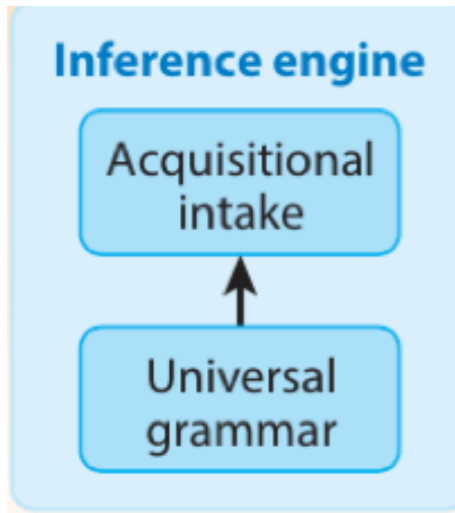

Information available

Conceptual cues + Syntactic-semantic knowledge
 Thematic roles and how to use them



Syntax

The ice was melted by the girl.

Subject

Indirect Object

Mapping to Syntax

+expmap

-expmap

Intermediate representations

UTAH

rUTAH

Agent > Experiencer >

Theme > Patient >

(Source, Goal, Instrument)

Thematic roles Agent, Experiencer, Patient, Theme, Goal, Source, Instrument...

Information available

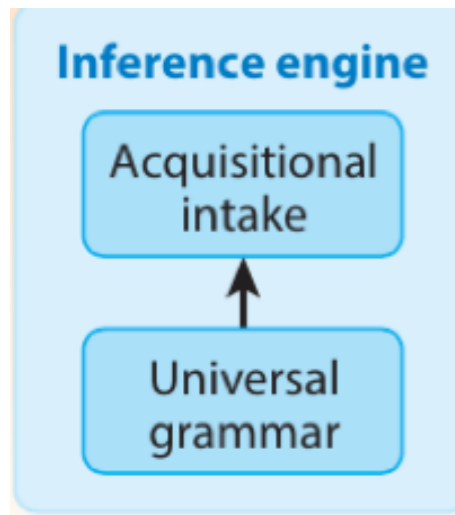

Syntactic frame

NP ____ S_{nonfinite} -surfmorph
 NP ____+past S_{nonfinite} +surfmorph

Animacy

+animate

The penguin tried
to climb.



-animate

The ice seemed
to melt.



Thematic roles and how to use them

UTAH

Agent > Experiencer > rUTAH

Theme > Patient >

(Source, Goal, Instrument)

-expmap

Subject Object Indirect Object

+expmap

Subject Object Indirect Object



Potential learning strategies

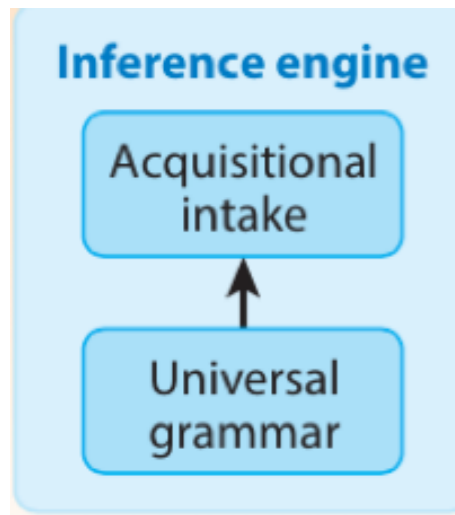

Animacy

+animate
The penguin tried
to climb.



-animate
The ice seemed
to melt.



Syntactic frame

NP ____ S_{nonfinite} -surfmorph
NP ____+past S_{nonfinite} +surfmorph

Thematic roles and how to use them

   UTAH

-expmap

Subject *Object* *Indirect Object*

Agent > Experiencer > rUTAH

+expmap

Subject *Object* *Indirect Object*

Theme > Patient >

(Source, Goal, Instrument)

  
movement?

Potential learning strategies

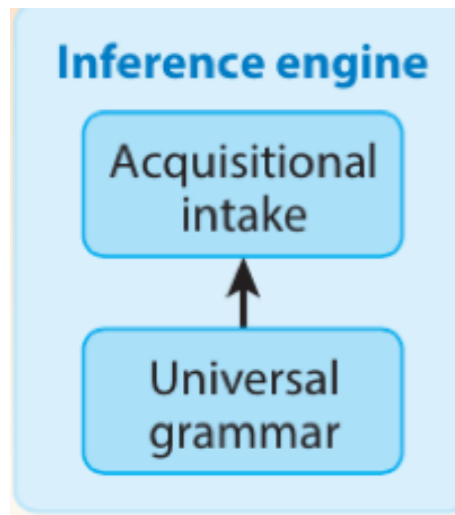

Animacy

+animate
The penguin tried
to climb.



-animate
The ice seemed
to melt.



Syntactic frame

Choice 1

NP _____ S_{nonfinite} -surfmorph
NP _____+past S_{nonfinite} +surfmorph

Thematic roles and how to use them

   UTAH

Agent > Experiencer > rUTAH
Theme > Patient >
(Source, Goal, Instrument)

-expmap

Subject Object Indirect Object

+expmap

Subject Object Indirect Object



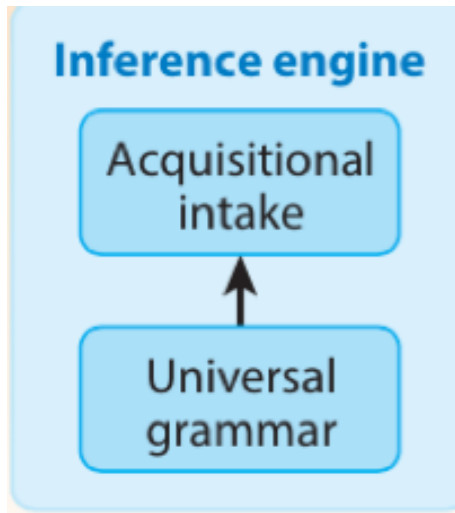

Potential learning strategies

Animacy

+animate
The penguin tried
to climb.



-animate
The ice seemed
to melt.



Syntactic frame

Choice 1

NP ____ S_{nonfinite} -surfmorph
NP ____+past S_{nonfinite} +surfmorph

Thematic roles and how to use them

UTAH

Choice 2

Agent > Experiencer > rUTAH
Theme > Patient >
(Source, Goal, Instrument)

-expmap	<i>Subject</i>	<i>Object</i>	<i>Indirect Object</i>
+expmap	<i>Subject</i>	<i>Object</i>	<i>Indirect Object</i>
	↑	↑	↑
	<i>movement?</i>		

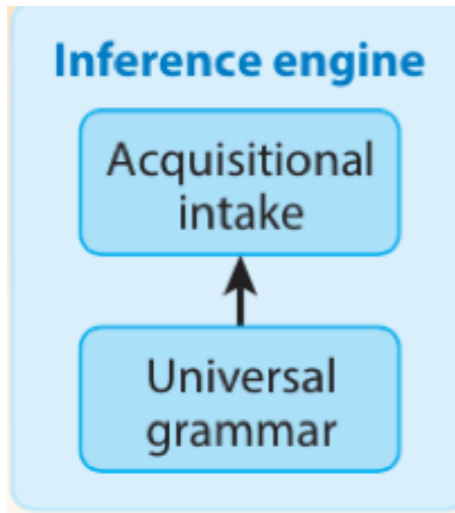

Potential learning strategies

Animacy

+animate
The penguin tried
to climb.



-animate
The ice seemed
to melt.



Syntactic frame

Choice 1

NP _____ S_{nonfinite} -surfmorph
 NP _____+past S_{nonfinite} +surfmorph

Thematic roles and how to use them

■ ■ ■ UTAH

Choice 2

Agent > Experiencer > rUTAH
 Theme > Patient >
 (Source, Goal, Instrument)

Choice 3

Subject Object Indirect Object -expmap
 Subject Object Indirect Object
 ↑ ↑ ↑
 movement?



3 binary choices = 8 strategies

Today's plan

Computational modeling

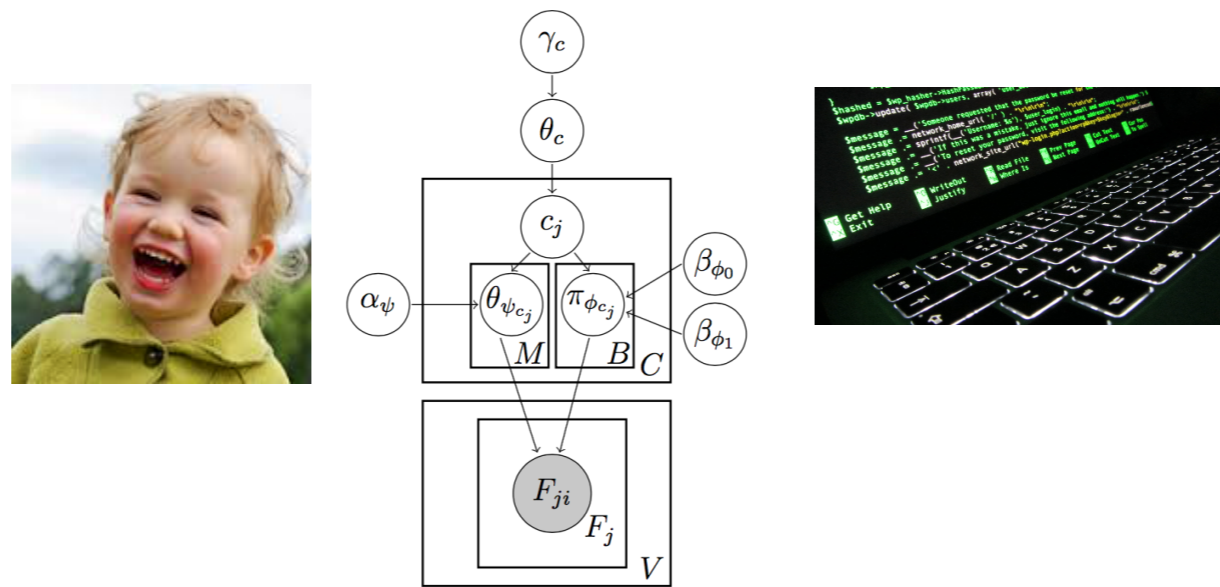

How do we model this?

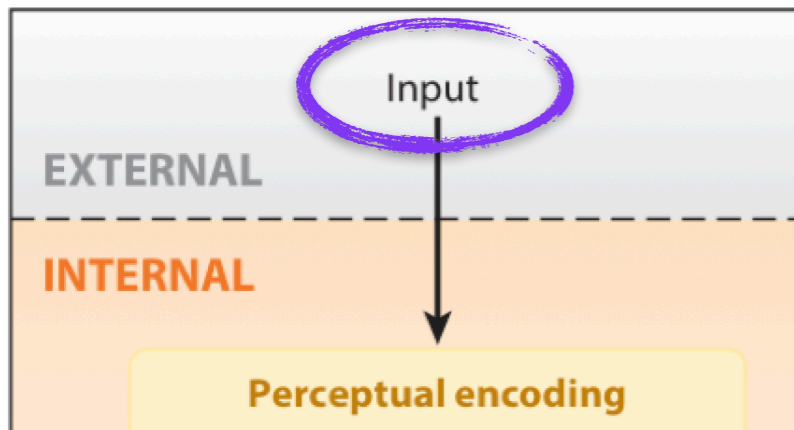

Goal: Model the developmental trajectory from 3 to 4 to 5 years old

“it’s falling off”

Input

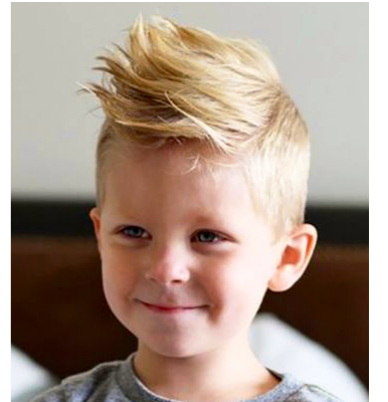

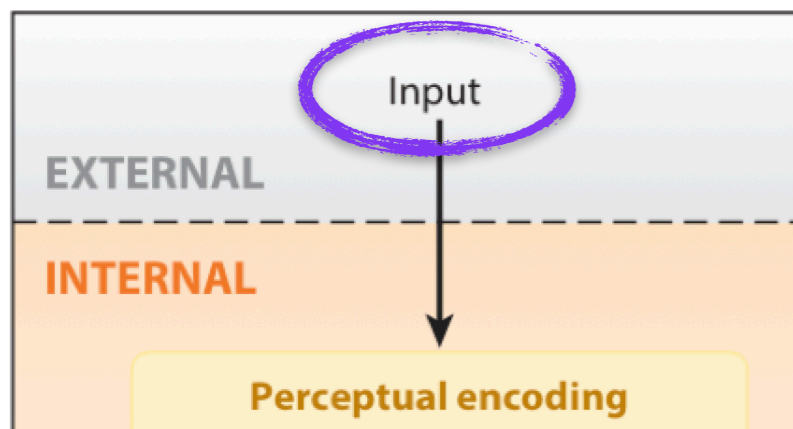

CHILDES Treebank

Goal: Model the developmental trajectory from 3 to 4 to 5 years old



Input:
Samples of child-directed speech

<3yrs



18 and 32 months
~40,000 utterances
239 verbs

<4yrs



18 and 48 months
~51,000 utterances
267 verbs

<5yrs



18 and 58 months
~56,500 utterances
284 verbs

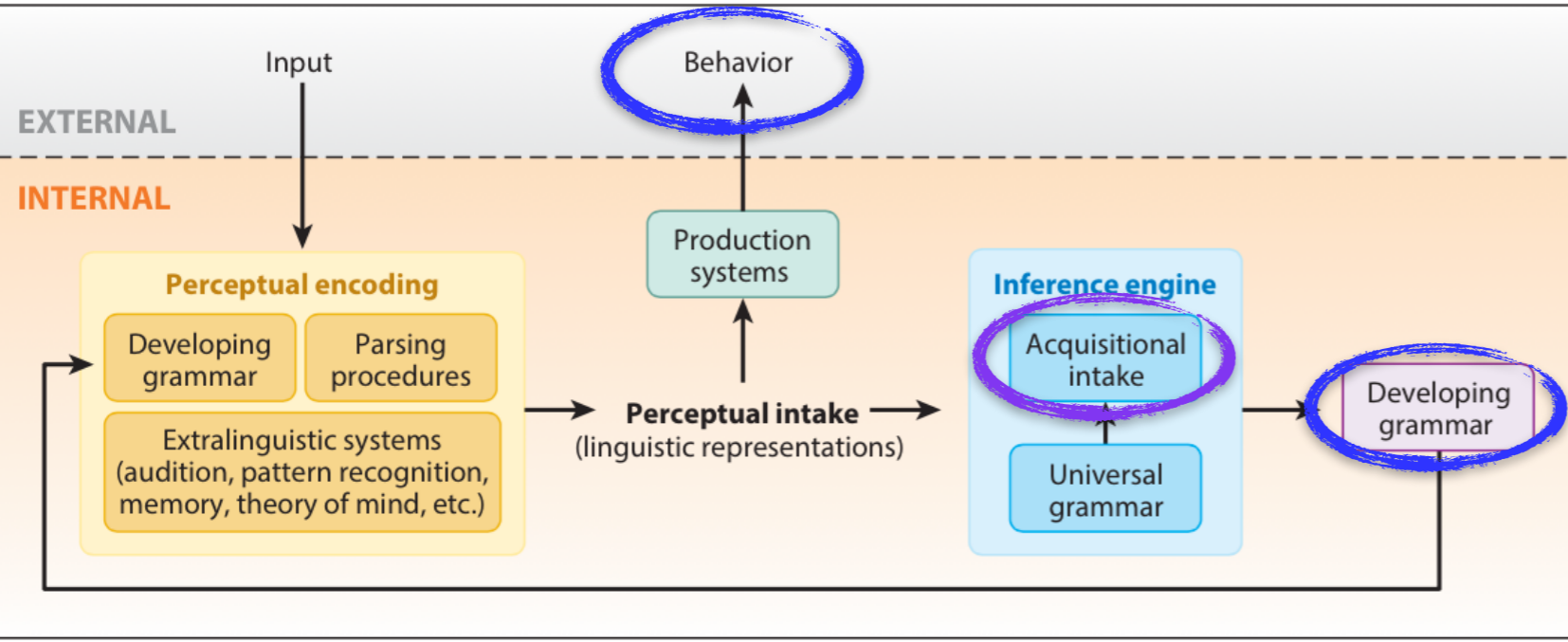

Goal: Model the developmental trajectory from 3 to 4 to 5 years old

<3yrs <4yrs <5yrs



Basic question: Is it possible for the child to use the **acquisitional intake** to achieve the **target knowledge/behavior**?

- +animate  -surfmorph
NP ____ S_{nonfinite}
- +surfmorph
NP ____+past S_{nonfinite}
- UTAH
- rUTAH Agent > Experiencer >
Theme > Patient >
(Source, Goal, Instrument)
- expmap Subject Object Indirect Object
- +expmap movement?

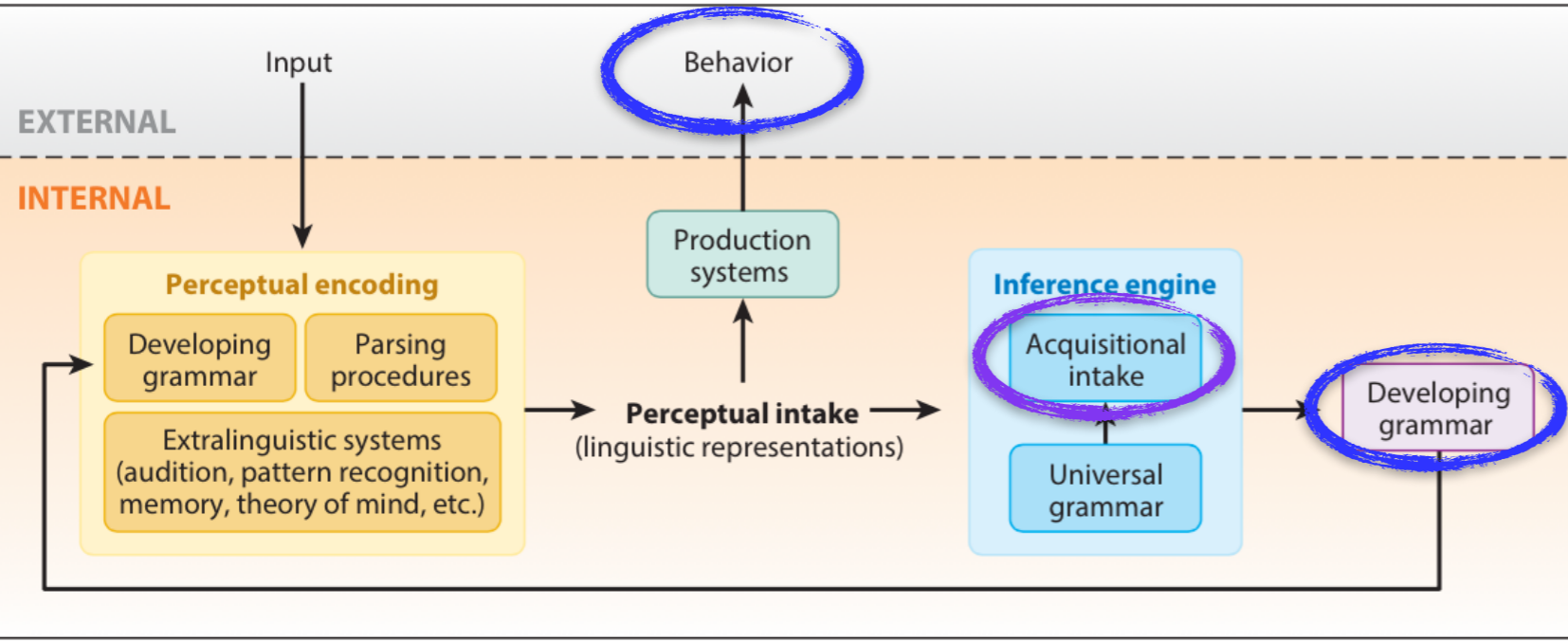

Goal: Model the developmental trajectory from 3 to 4 to 5 years old

<3yrs <4yrs <5yrs



Basic question: Is it possible for the child to use the **acquisitional intake** to achieve the **target knowledge/behavior**?

Ideal learner model: not concerned with the cognitive limitations and incremental learning restrictions children have.

Concerned with what **assumptions** are **useful** for children to have.



- surfmorph
- +surfmorph
- UTAH
- rUTAH
- expmap
- +expmap

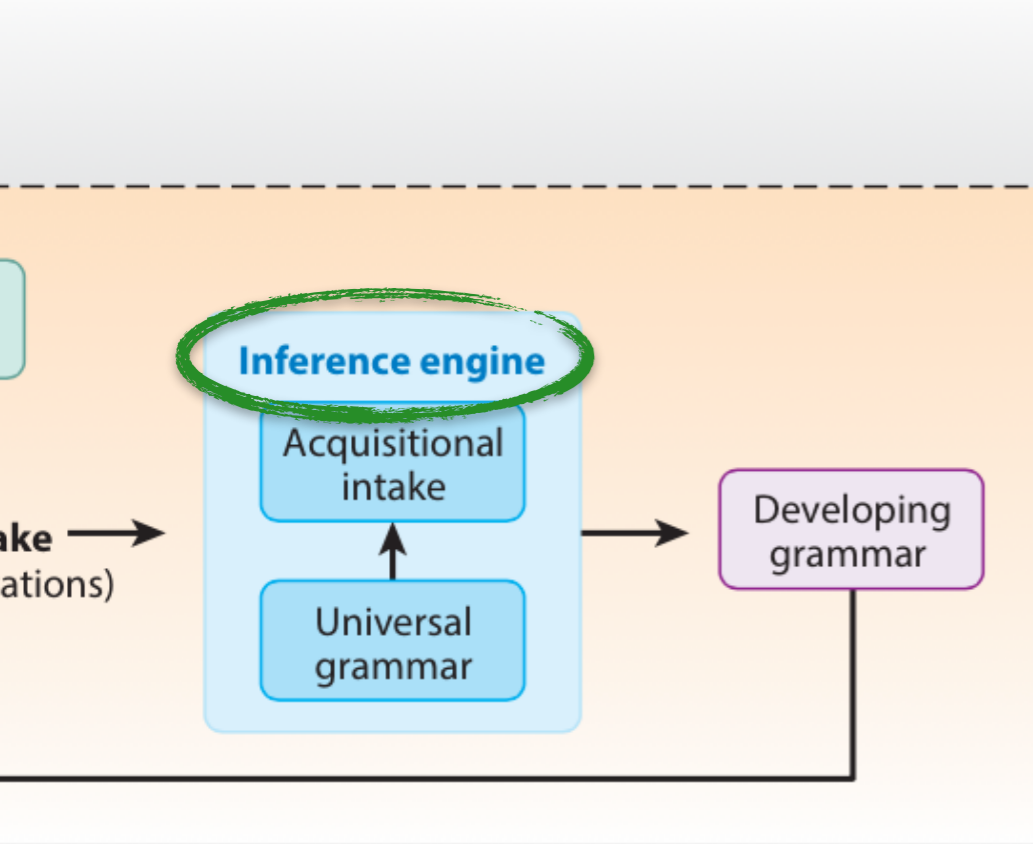

Learners use a generative model of how the observable data for each verb are created.

Goal: Model the developmental trajectory from 3 to 4 to 5 years old
 <3yrs <4yrs <5yrs

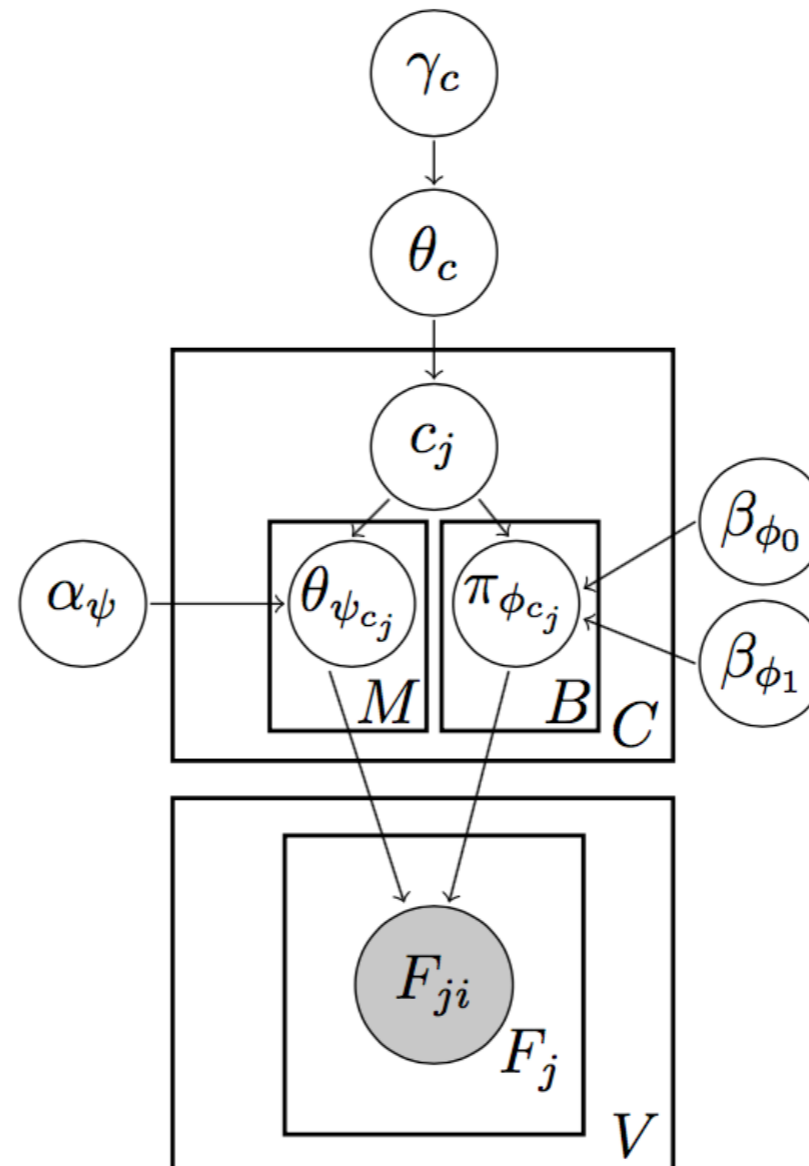
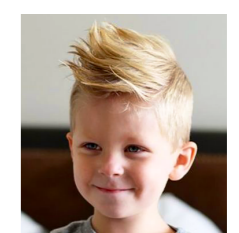

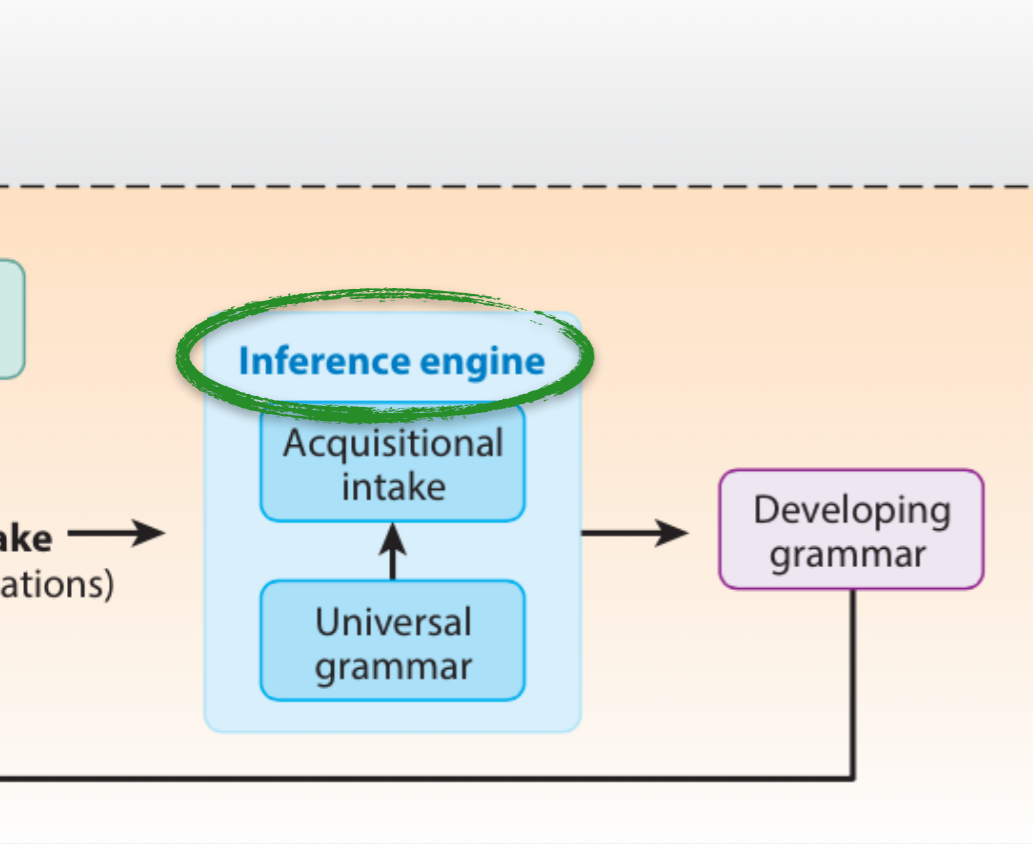

Learners use a generative model of how the observable data for each verb are created.

FALL

Goal: Model the developmental trajectory from 3 to 4 to 5 years old

<3yrs <4yrs <5yrs

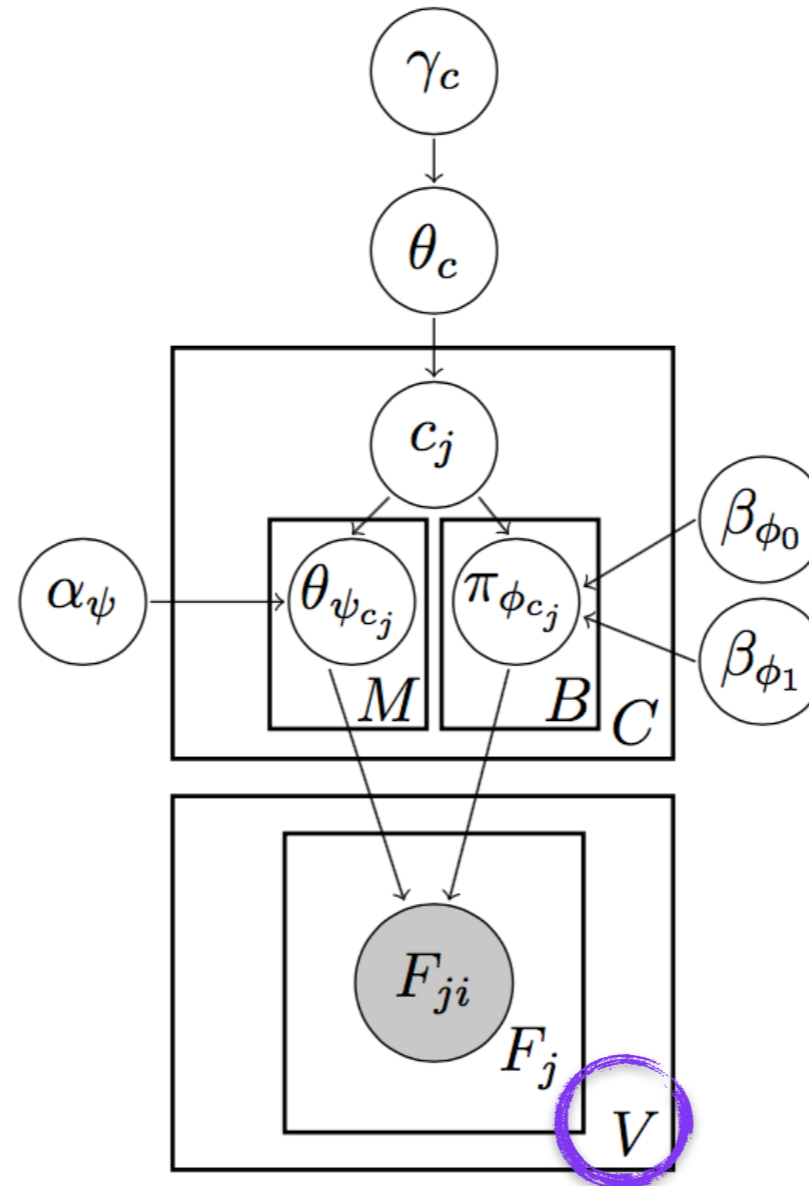
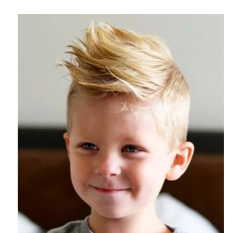

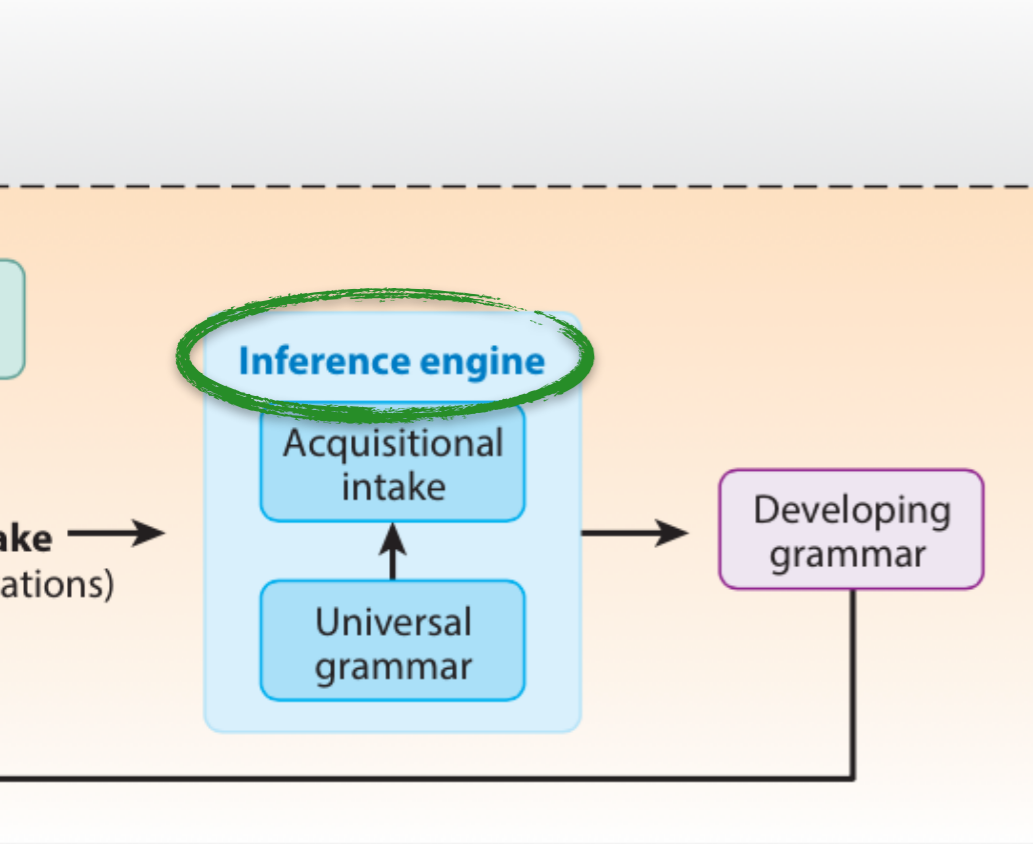

Goal: Model the developmental trajectory from 3 to 4 to 5 years old

<3yrs <4yrs <5yrs



Each verb appears in a certain number of instances in the input.

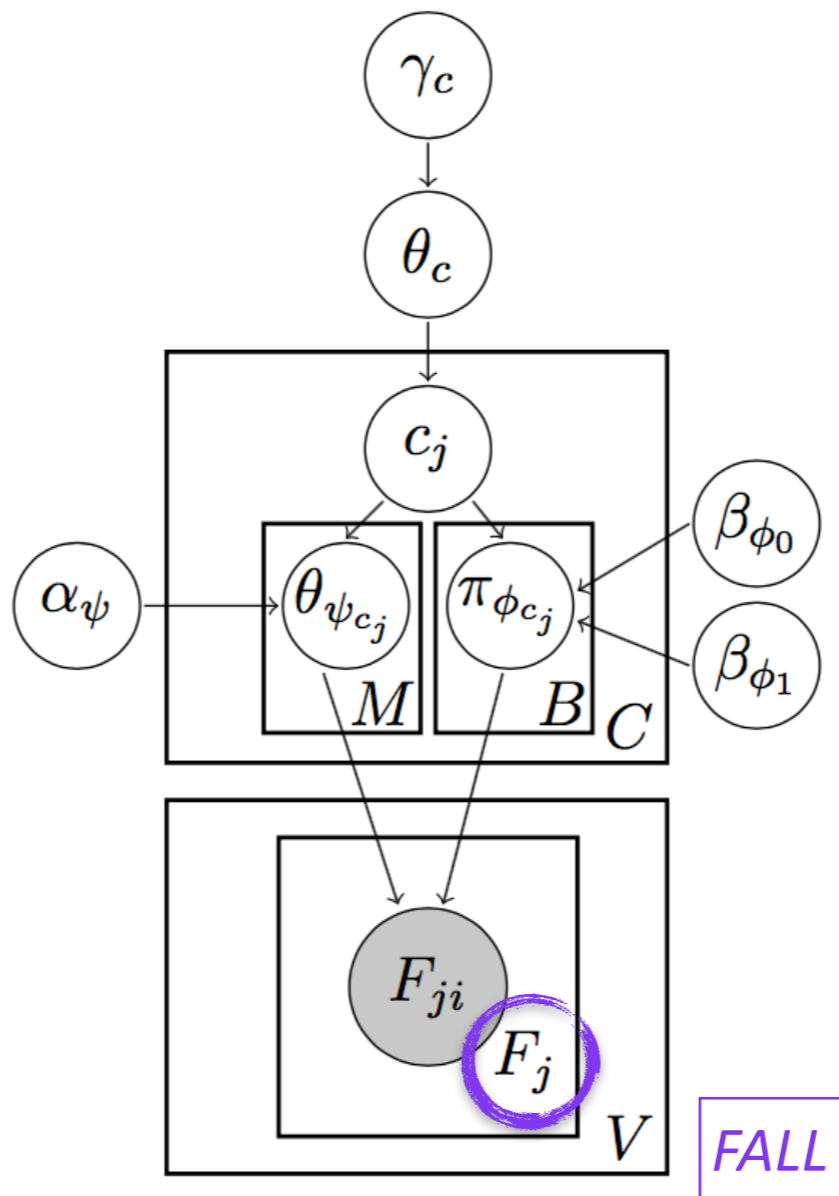
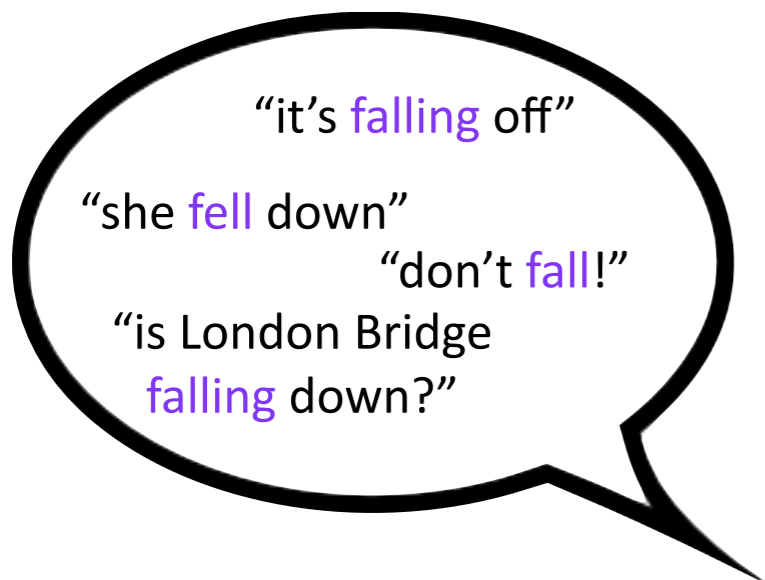

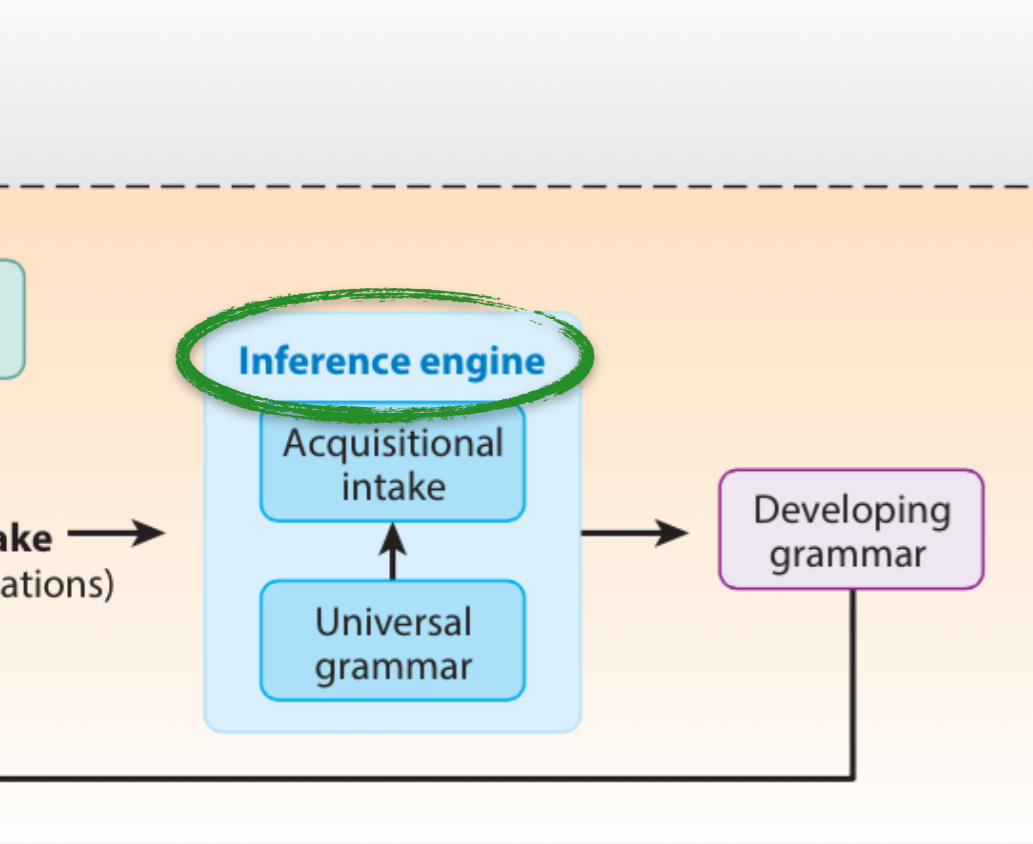

Goal: Model the developmental trajectory from 3 to 4 to 5 years old

<3yrs

<4yrs

<5yrs

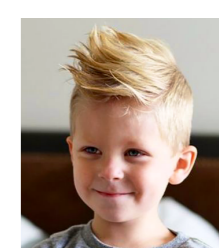

Each instance is observed some number of times.

“it’s falling off”
 (3x) “it’s falling off”
 “it’s falling off”

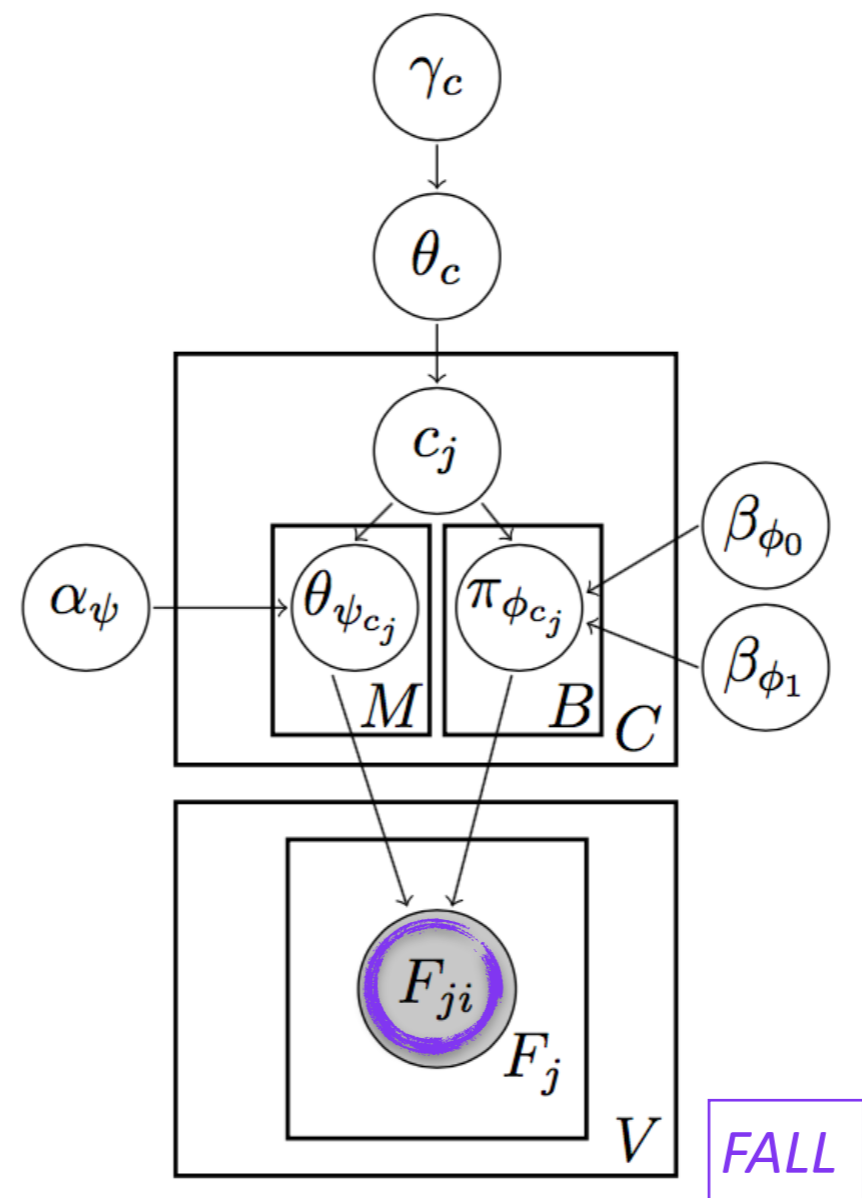

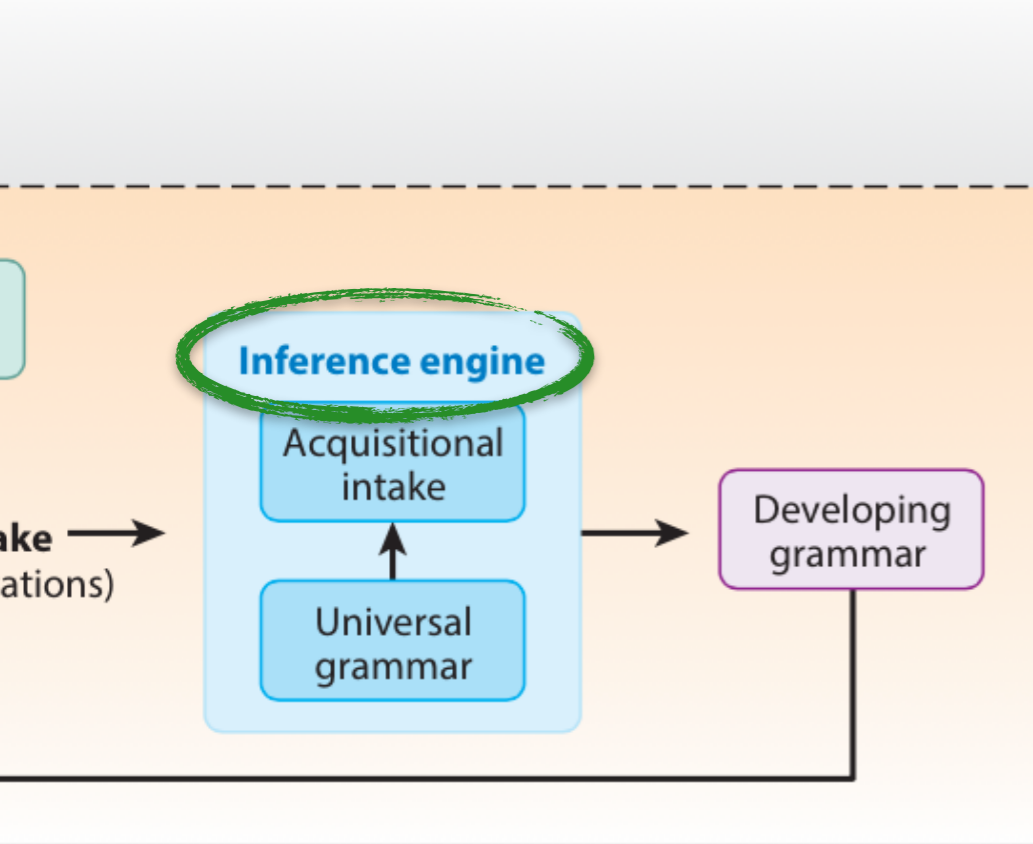

Goal: Model the developmental trajectory from 3 to 4 to 5 years old

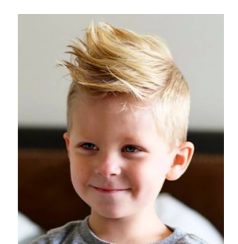

Each verb belongs to some class which determines its linguistic behavior.

The learner doesn't know beforehand how many classes there are or which verbs belong to which.

Objective: Infer verb class

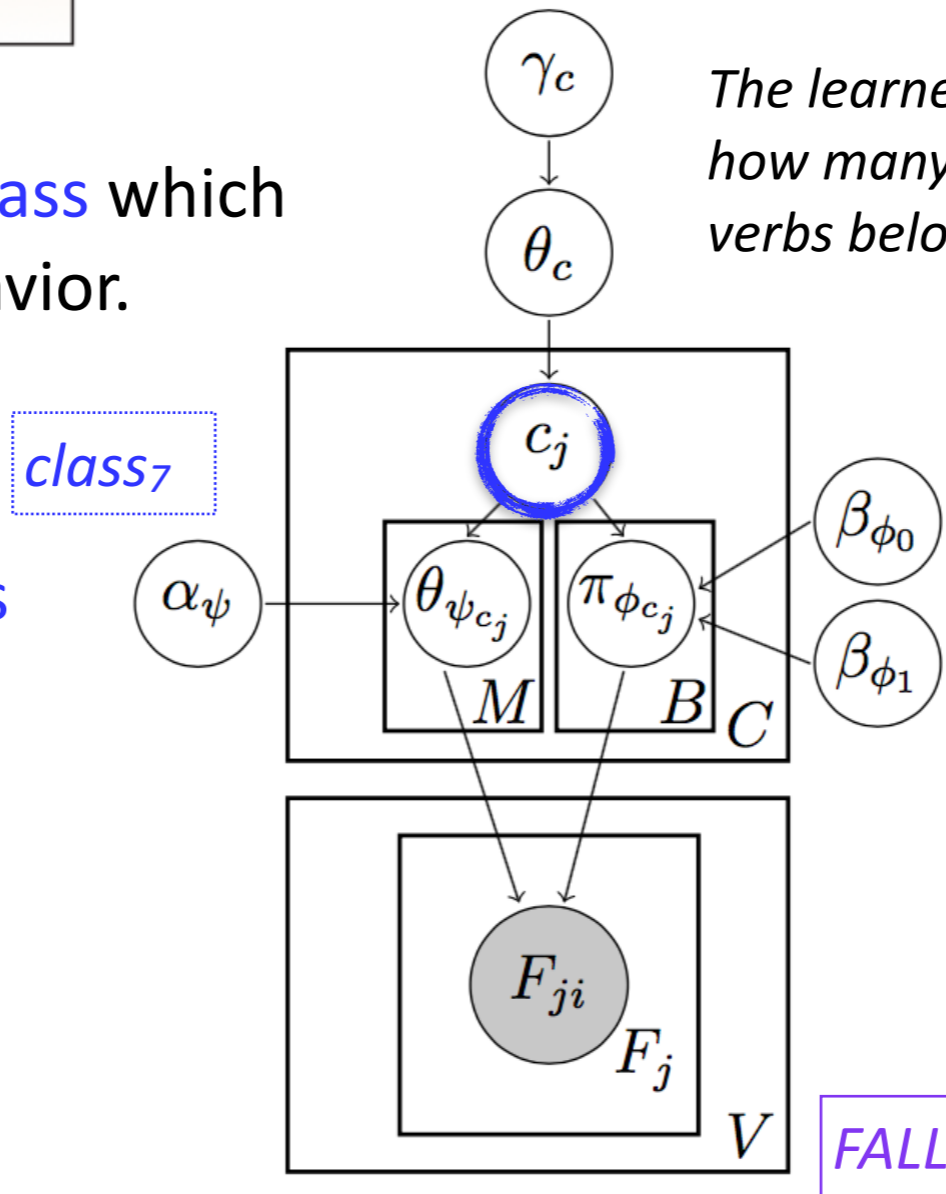

“it’s falling off”
 (3x) “it’s falling off”
 “it’s falling off”

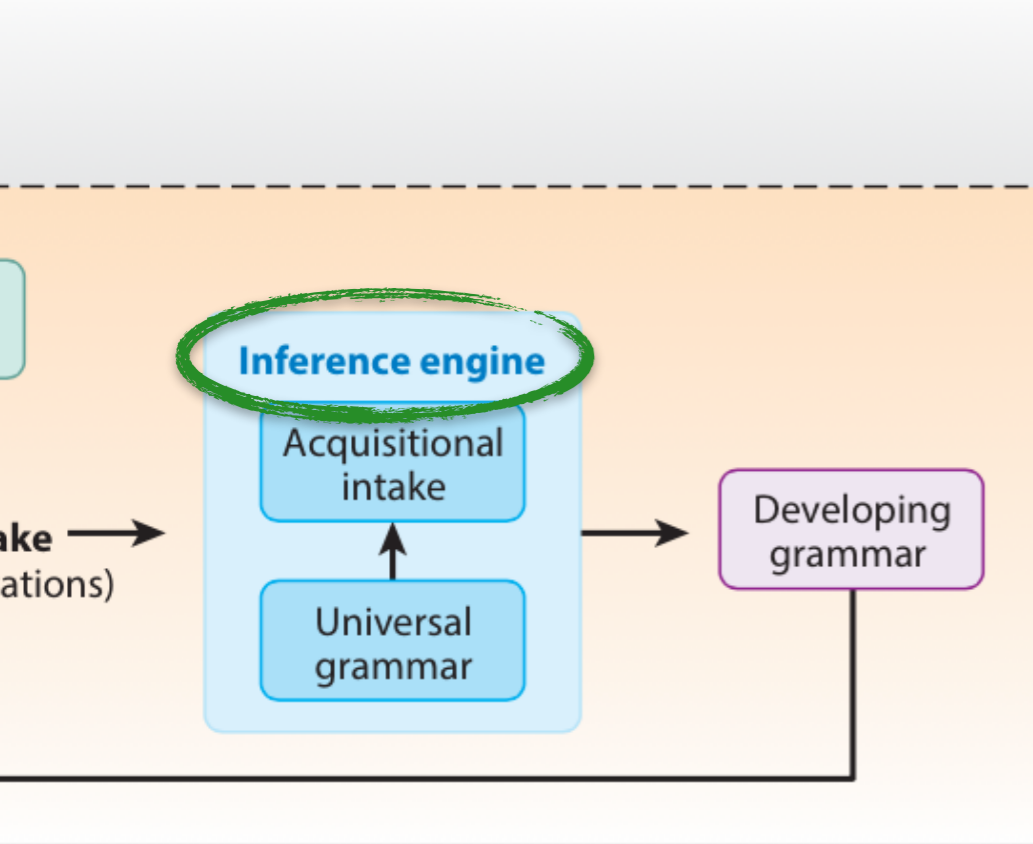

Depending on the verb **class**, the **observed usage** will have **certain characteristics**.

Goal: Model the **developmental trajectory** from 3 to 4 to 5 years old

<3yrs

<4yrs

<5yrs

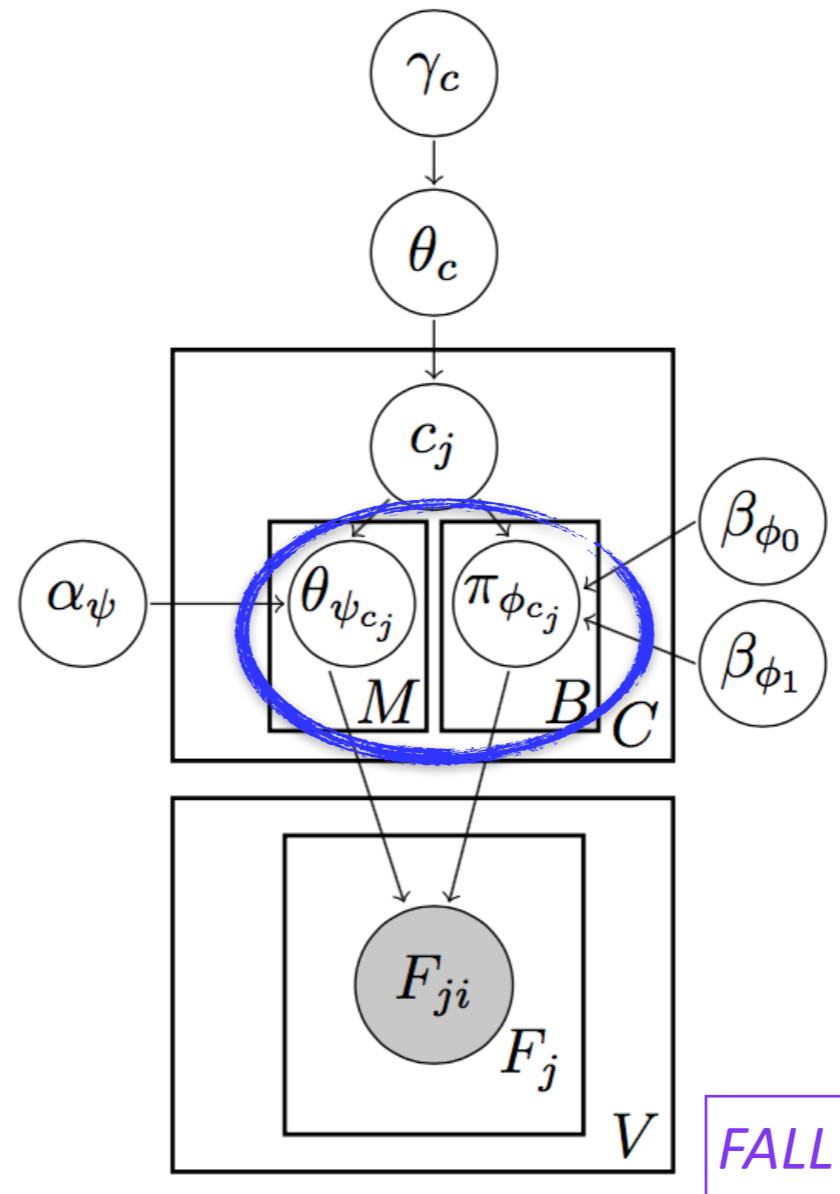
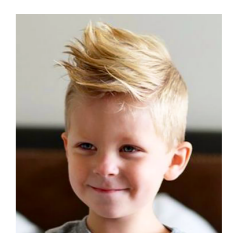

class₇

FALL

“it’s falling off”
 (3x) “it’s falling off”
 “it’s falling off”

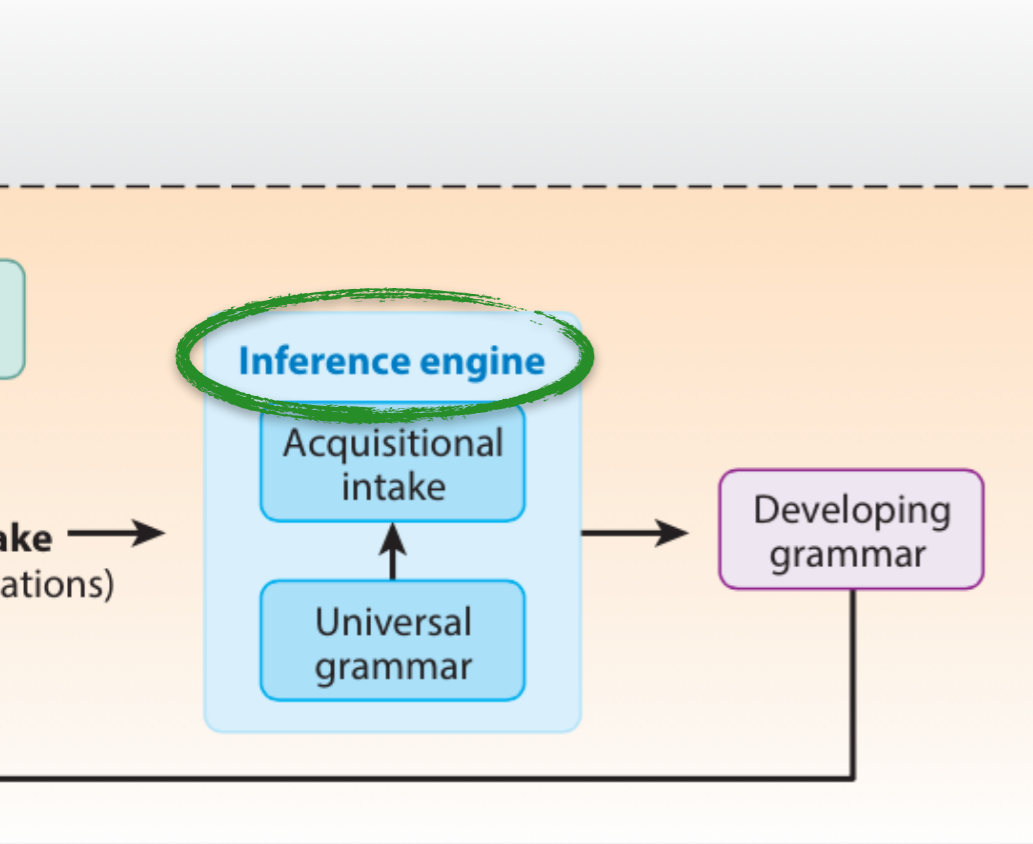

These characteristics include binary choices such as whether the subject is animate or not.

Goal: Model the developmental trajectory from 3 to 4 to 5 years old

<3yrs

<4yrs

<5yrs

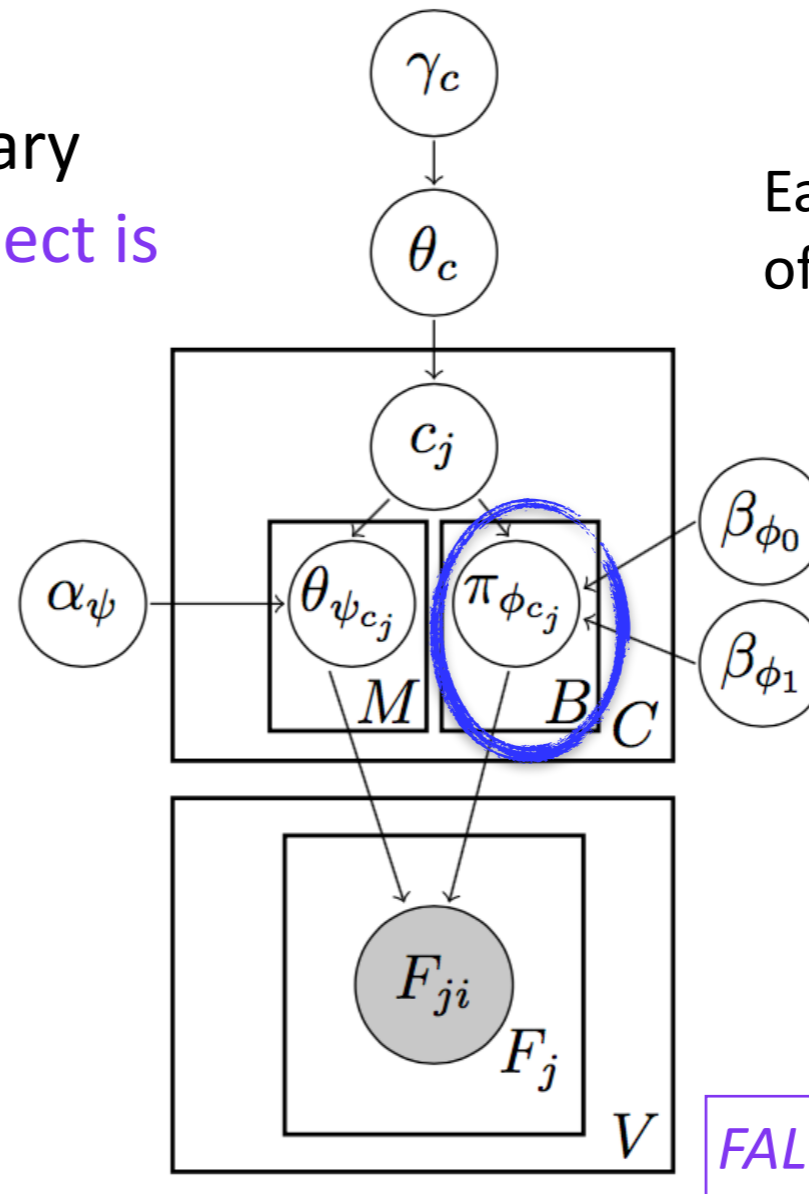
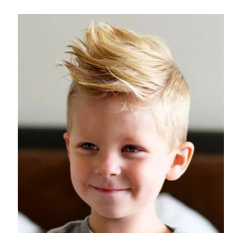

Each class has a probability of preferring each option.

class₇

<i>+anim</i>	<i>Subject</i>	<i>-anim</i>
<i>0.3</i>		<i>0.7</i>

-anim
 "it's falling off"
 (3x) "it's falling off"
 "it's falling off"

FALL

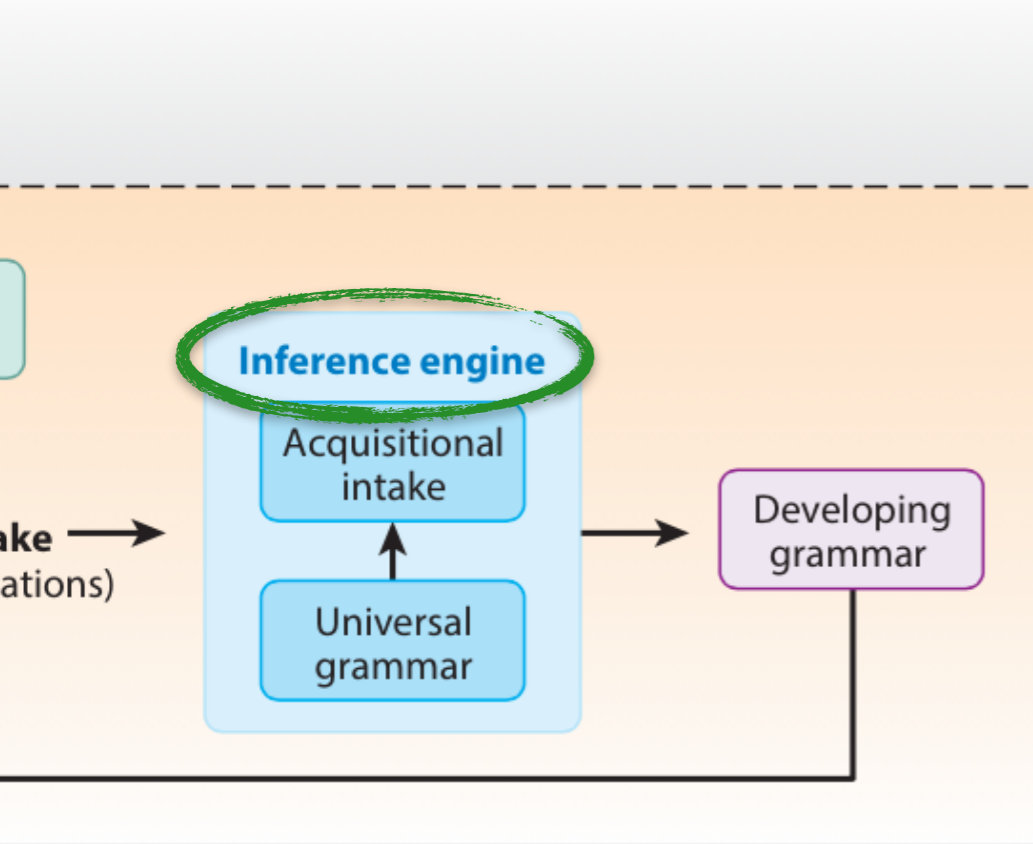

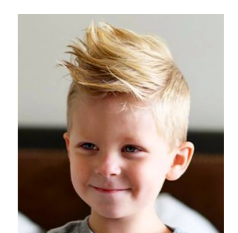

Goal: Model the developmental trajectory from 3 to 4 to 5 years old

<3yrs <4yrs <5yrs



Binary choices:

- +/-animate subject
- +/-animate object
- +/-animate indirect object
- +/-movement (when +exp-mapping)

+animate  -animate 

Subject Object Indirect Object

movement?

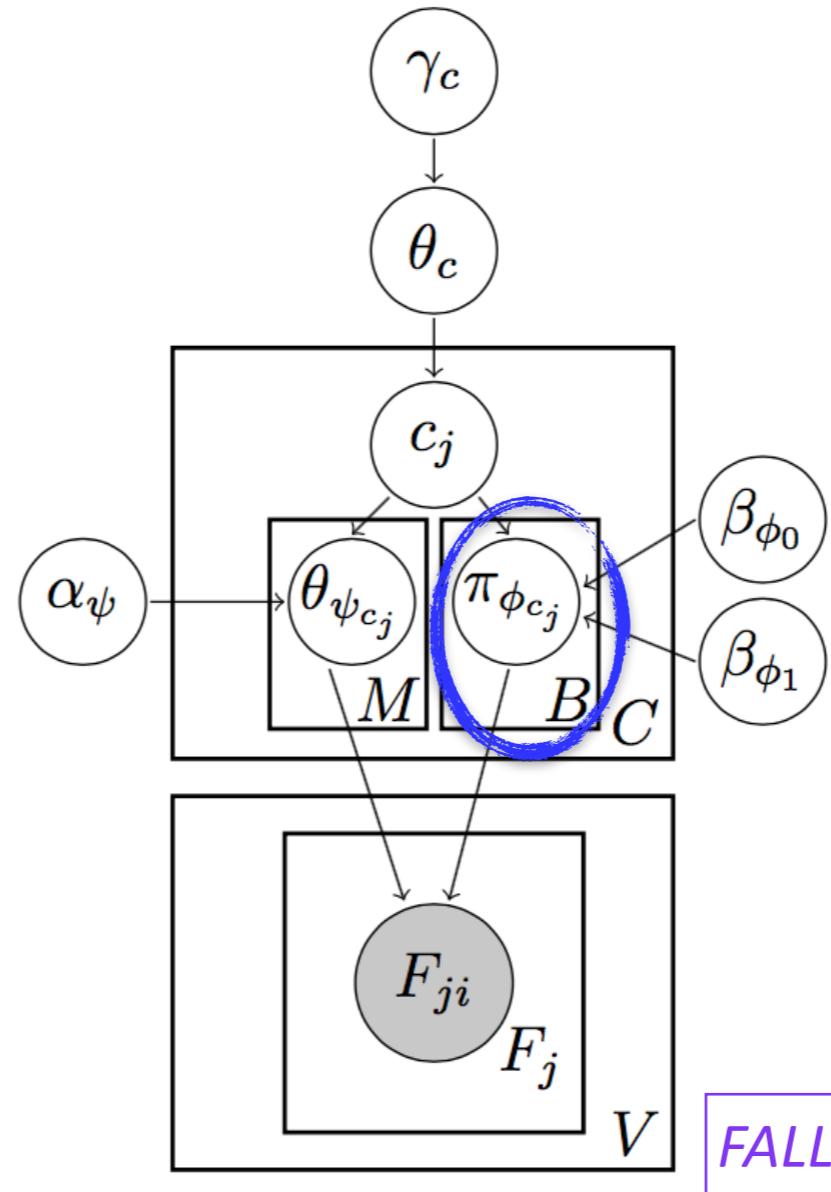

class ₇		
+anim	Subject	-anim
0.3		0.7

-anim
 "it's falling off"
 (3x) "it's falling off"
 "it's falling off"

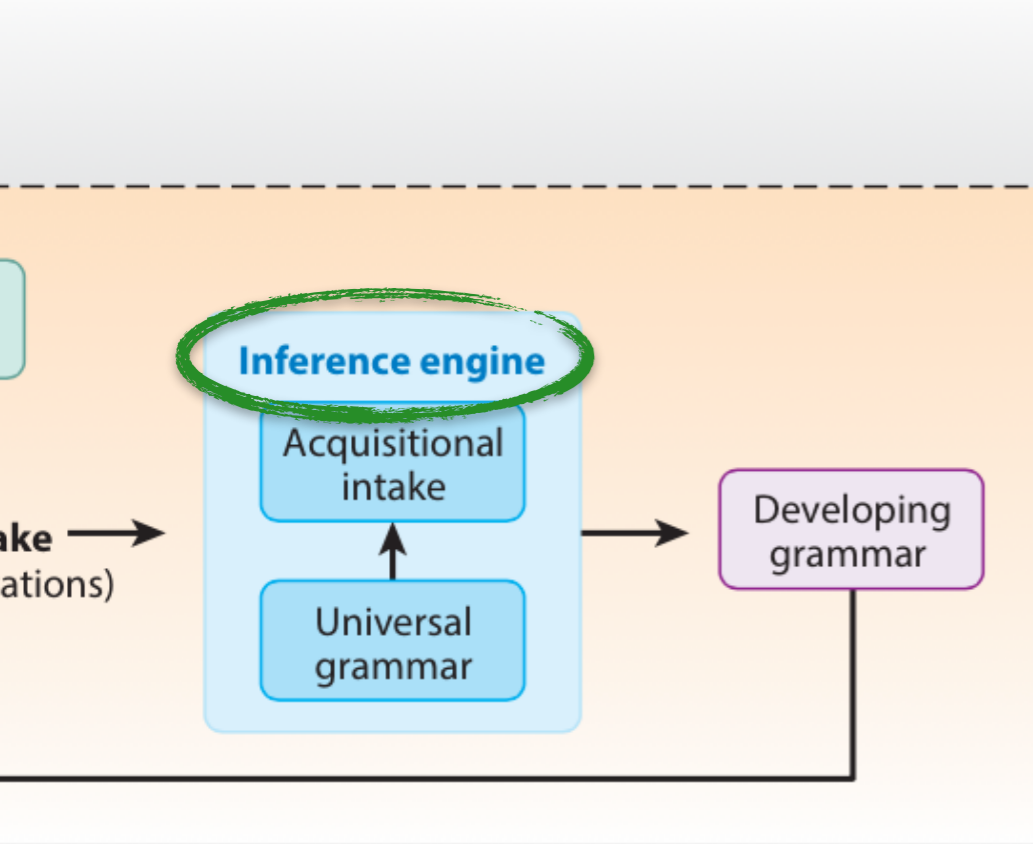

Goal: Model the developmental trajectory from 3 to 4 to 5 years old

<3yrs <4yrs <5yrs

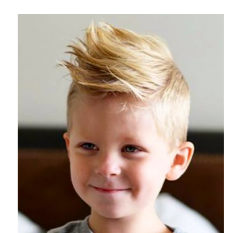

These characteristics include multinomial choices such as which syntactic frame a verb appears in.

Each class has a probability of preferring each option.

- NP V PRT* 0.3
- NP V* 0.25
- ...
- NP V S* 0

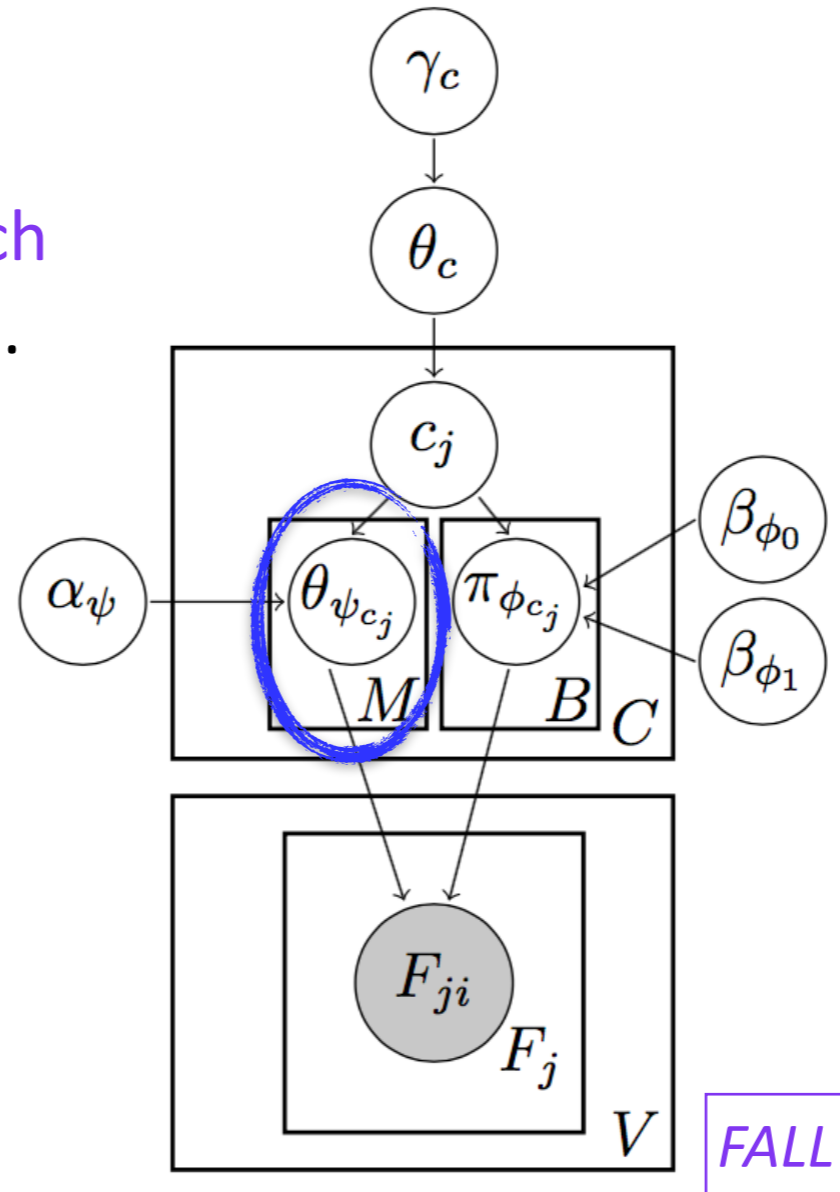

class₇

+anim Subject -anim
0.3 0.7

-anim
"it's falling off"
(3x) *NP V PRT*
"it's falling off"
"it's falling off"

FALL

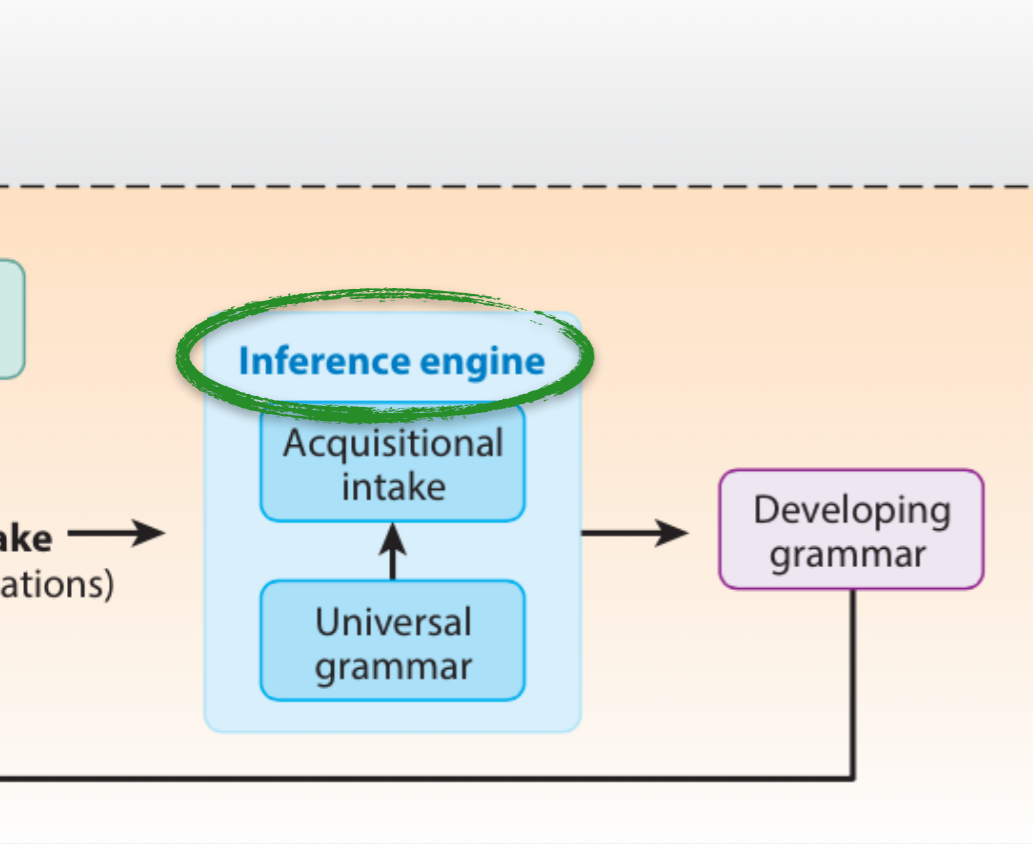

Goal: Model the developmental trajectory from 3 to 4 to 5 years old

<3yrs <4yrs <5yrs

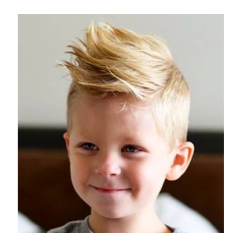

Multinomial choices:

- which syntactic frame is used **NP V PRT** (if -exp-mapping)
- position of **doer/Highest** role
- position of **done-to/next-highest** role
- position of **done-by/third-highest** role



Agent > Experiencer >
 Theme > Patient >
 (Source, Goal, Instrument)

Subject Object Indirect Object

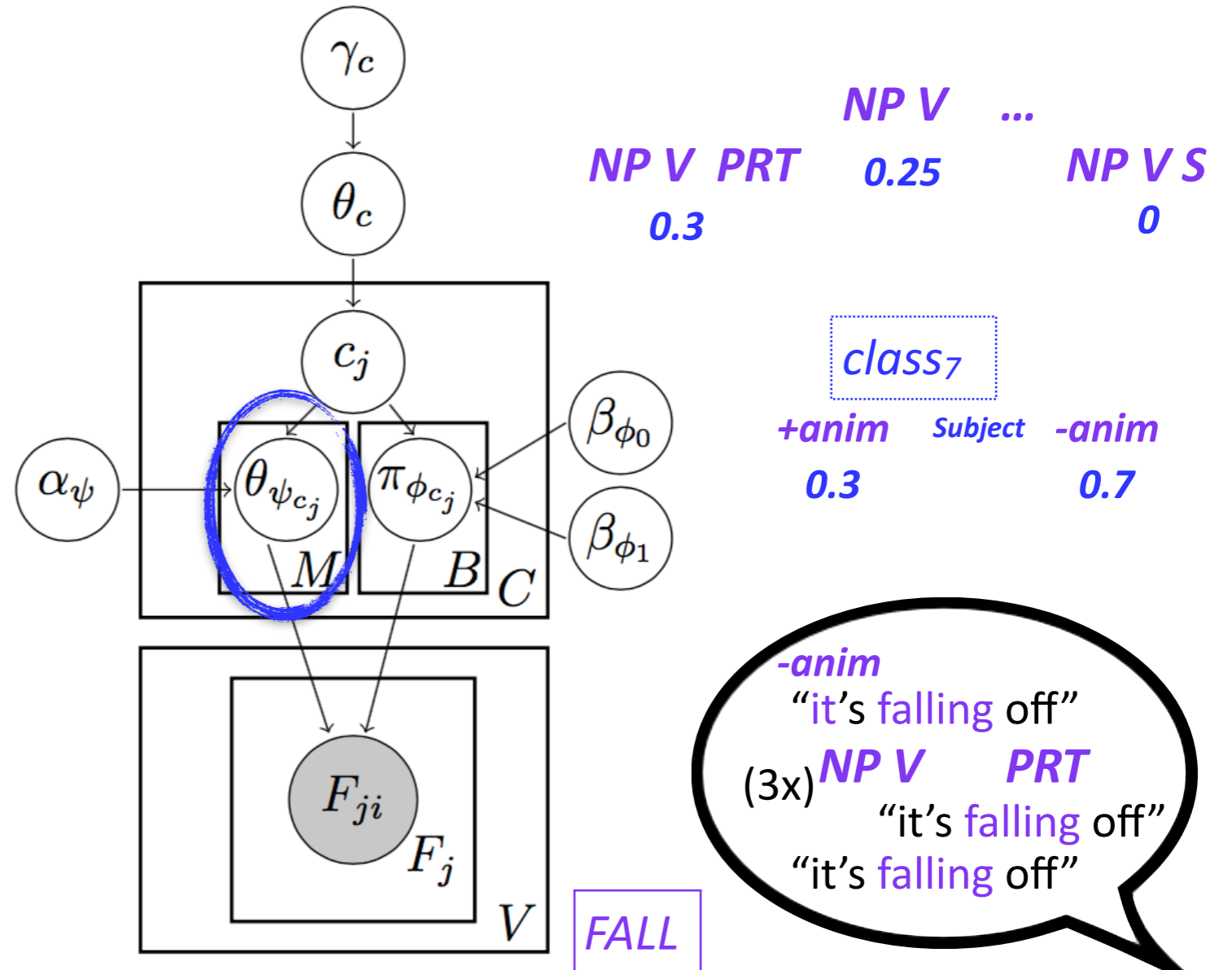

-anim
 "it's falling off"
 (3x) NP V PRT
 "it's falling off"
 "it's falling off"

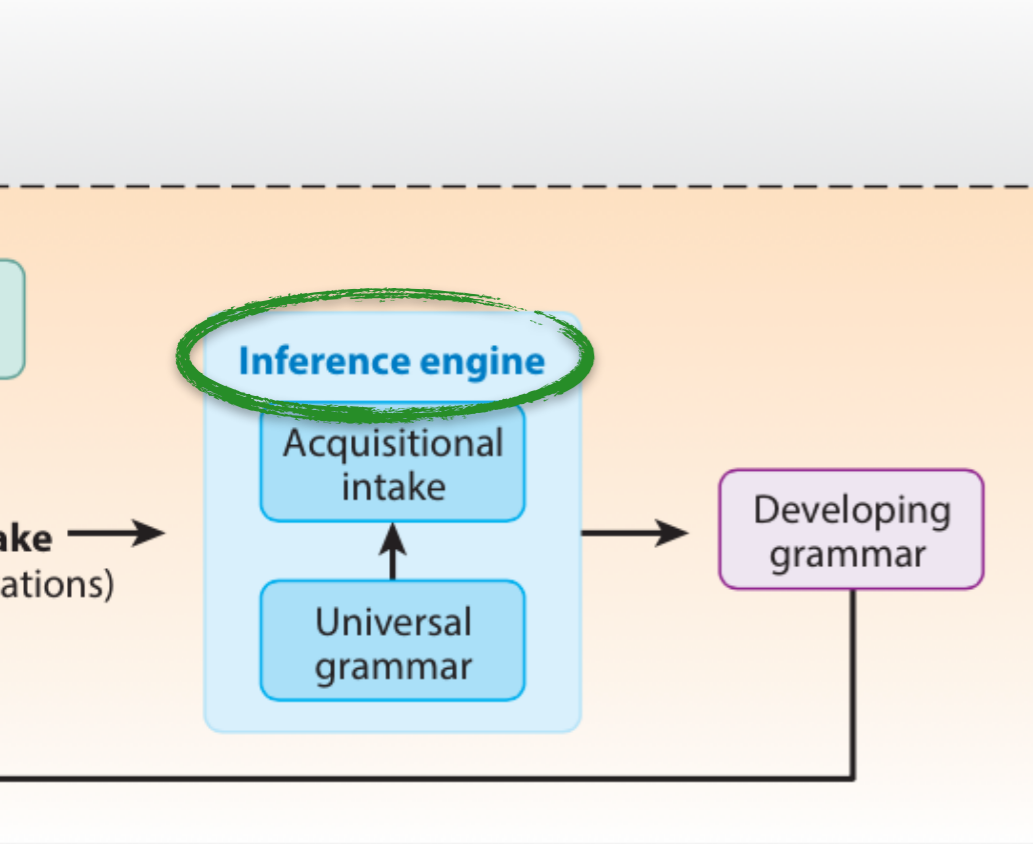

Goal: Model the developmental trajectory from 3 to 4 to 5 years old

<3yrs

<4yrs

<5yrs

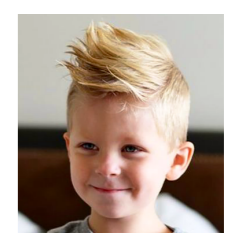

Using the observed instances of verb usage, Bayesian inference can be used to determine ...

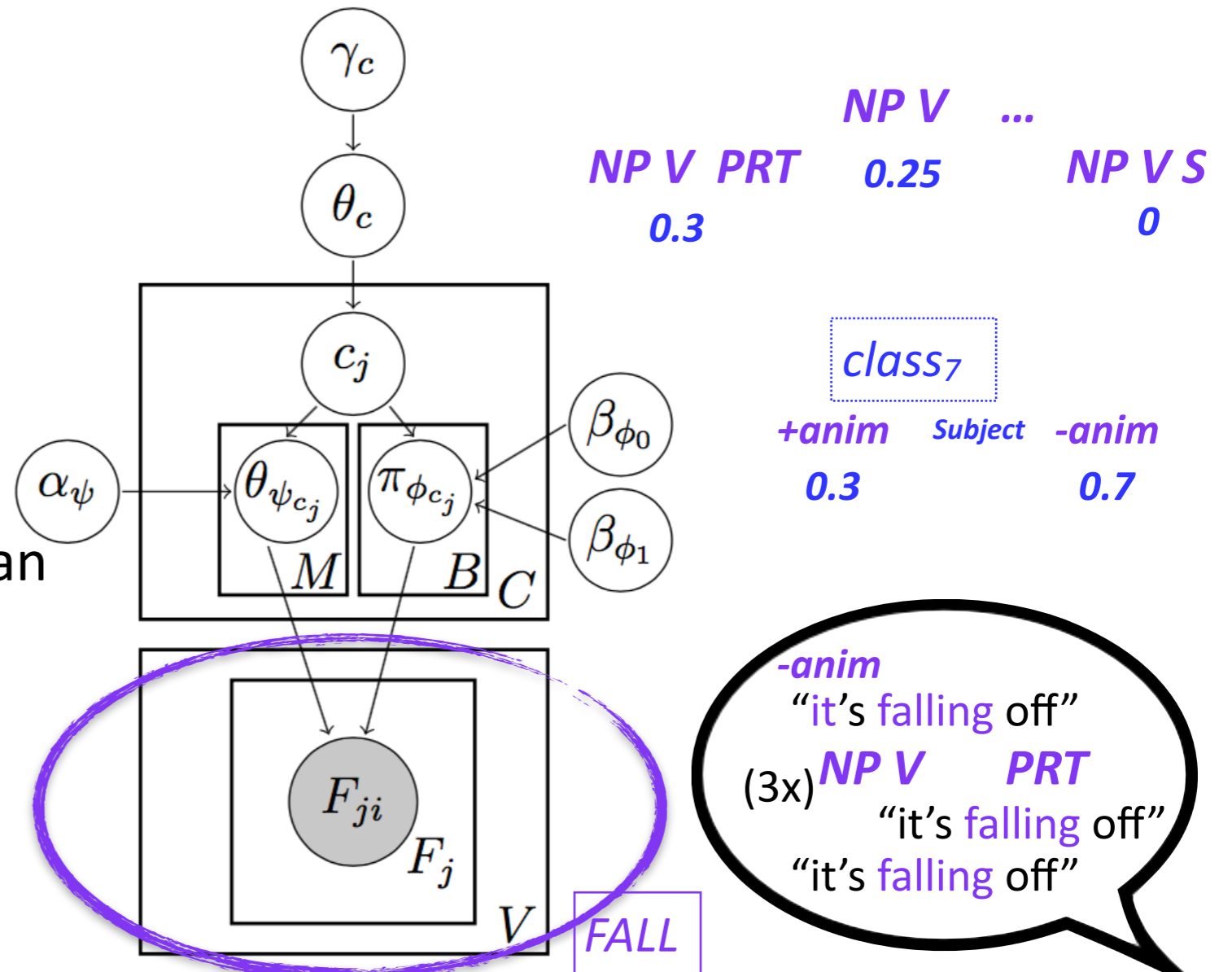

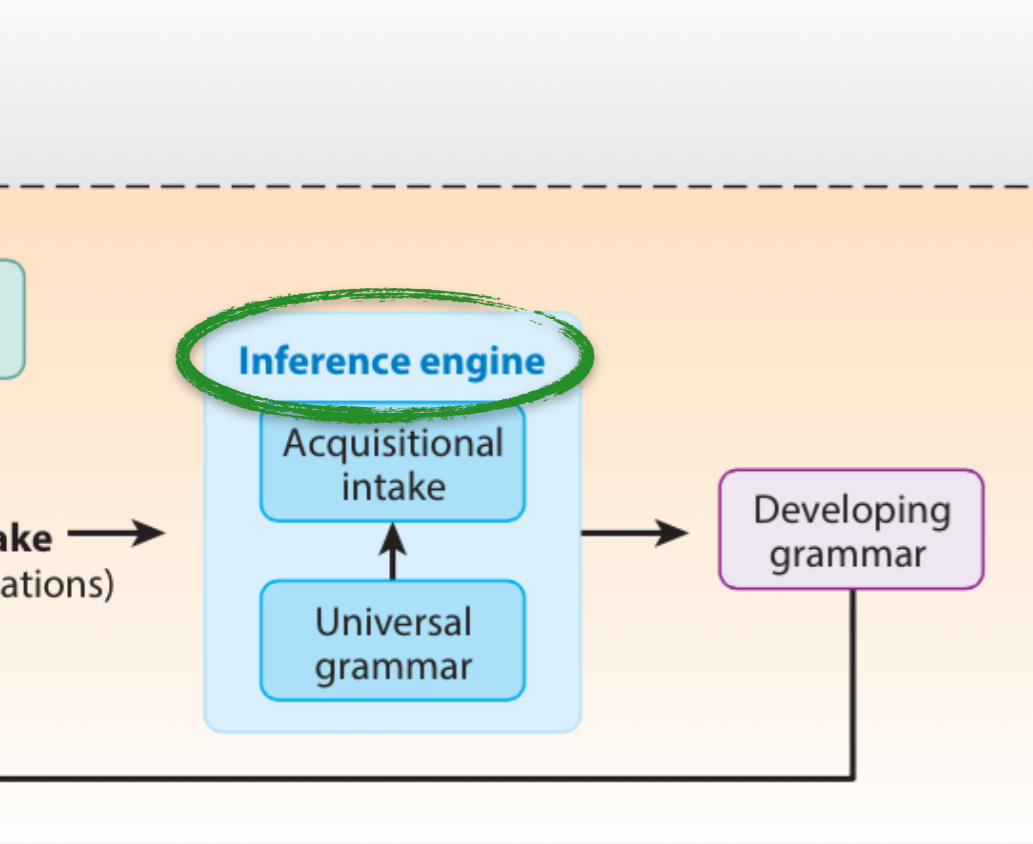

Goal: Model the developmental trajectory from 3 to 4 to 5 years old

<3yrs <4yrs <5yrs

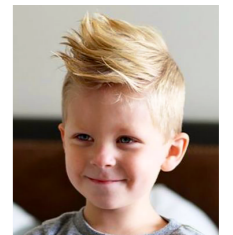

Using the observed instances of verb usage, Bayesian inference can be used to determine

- how many classes there are

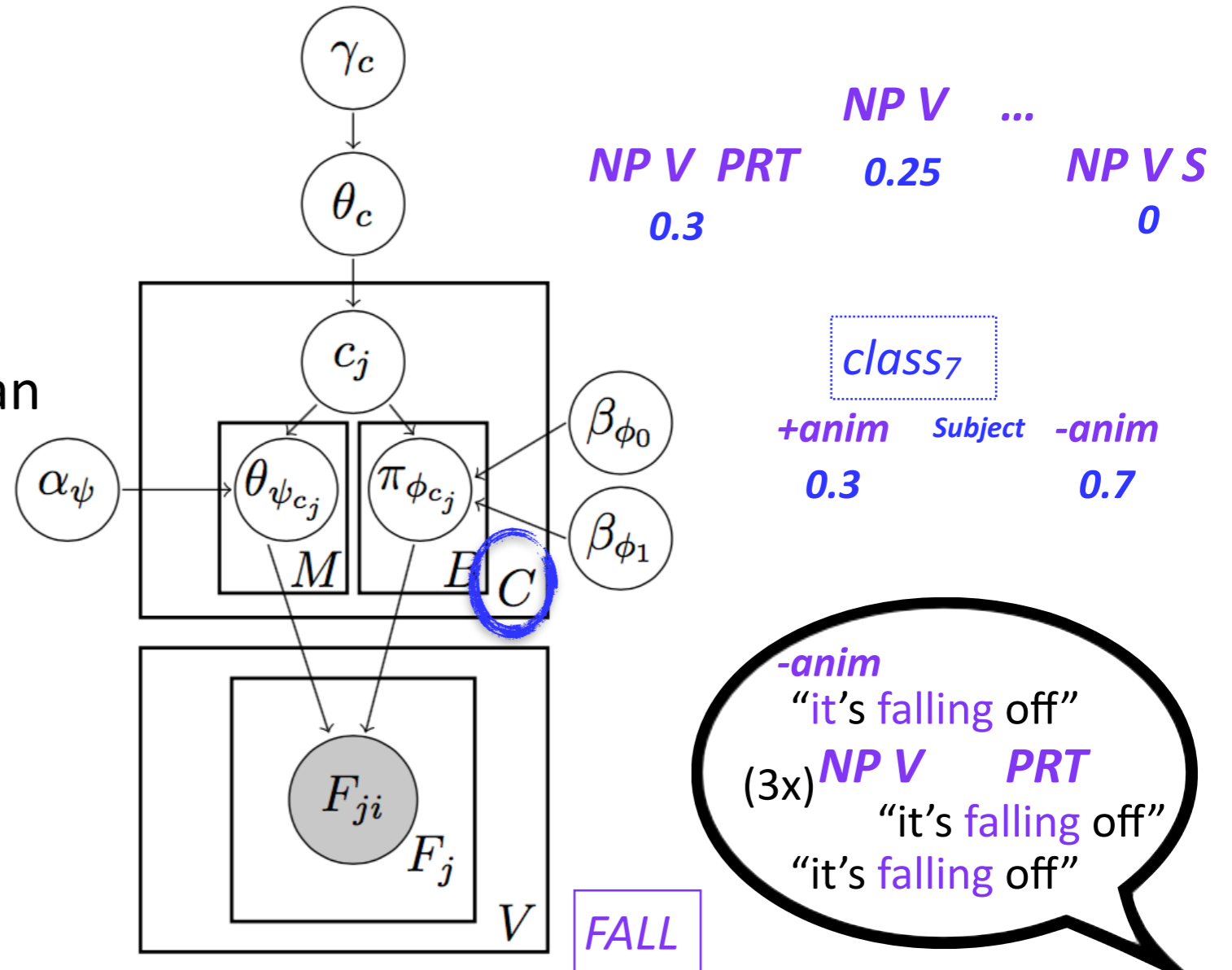

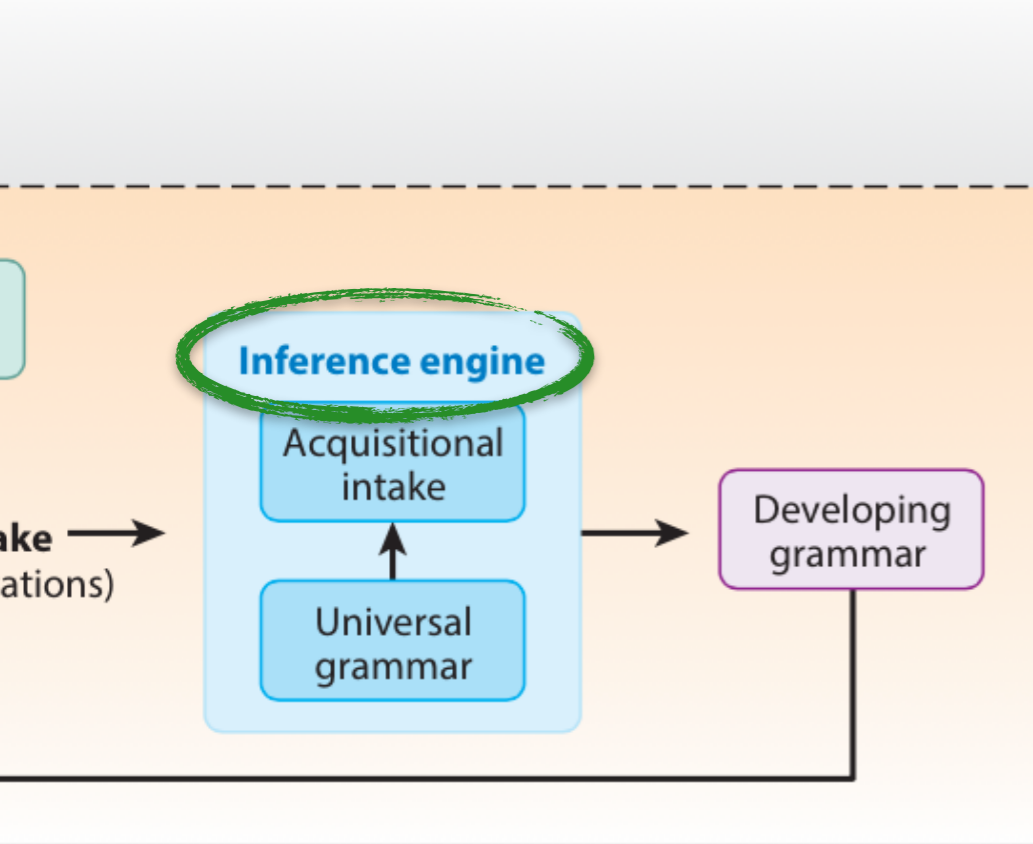

Goal: Model the developmental trajectory from 3 to 4 to 5 years old

<3yrs <4yrs <5yrs

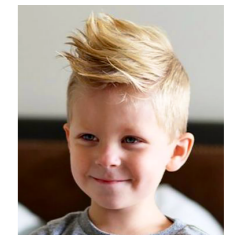

Using the observed instances of verb usage, Bayesian inference can be used to determine

- how many classes there are
- which class each verb belongs to

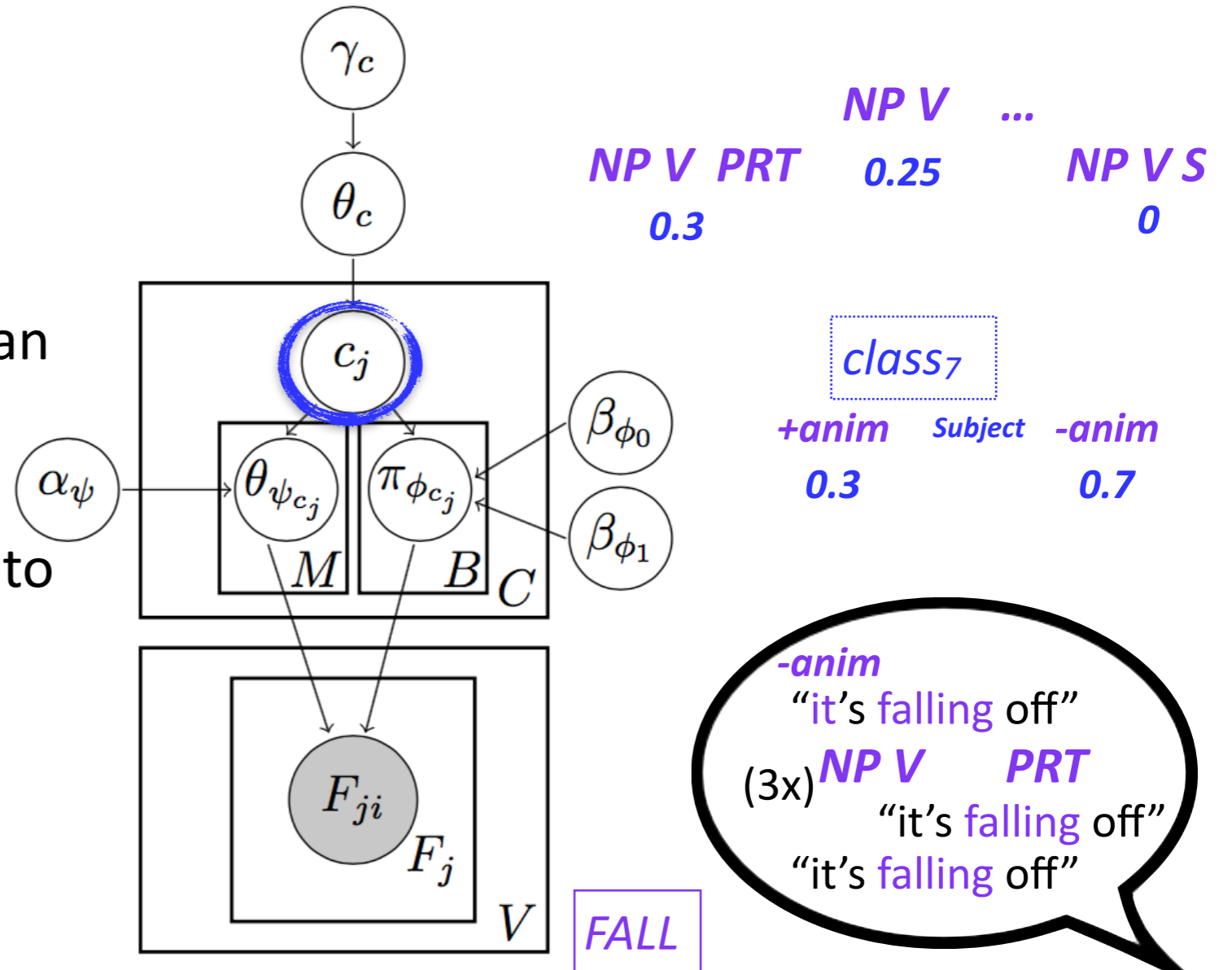

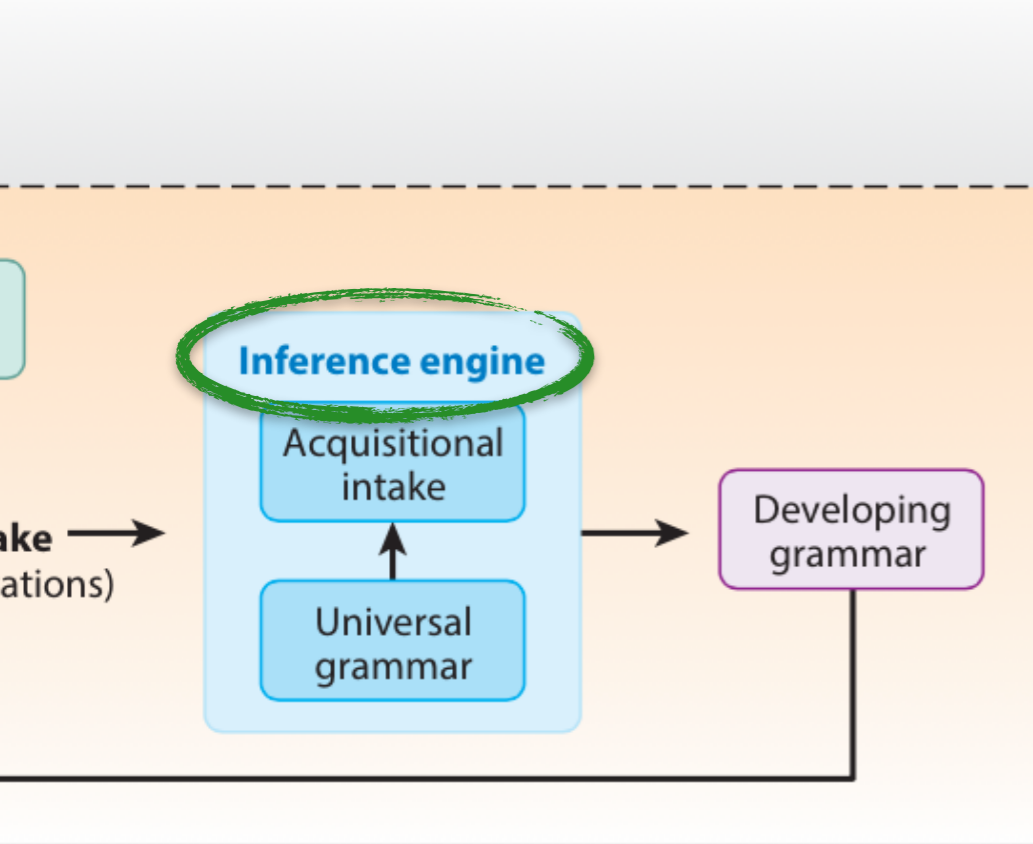

Goal: Model the developmental trajectory from 3 to 4 to 5 years old

<3yrs <4yrs <5yrs

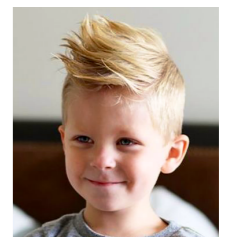

Using the observed instances of verb usage, Bayesian inference can be used to determine

- how many classes there are
- which class each verb belongs to
- what the characteristics are of each class

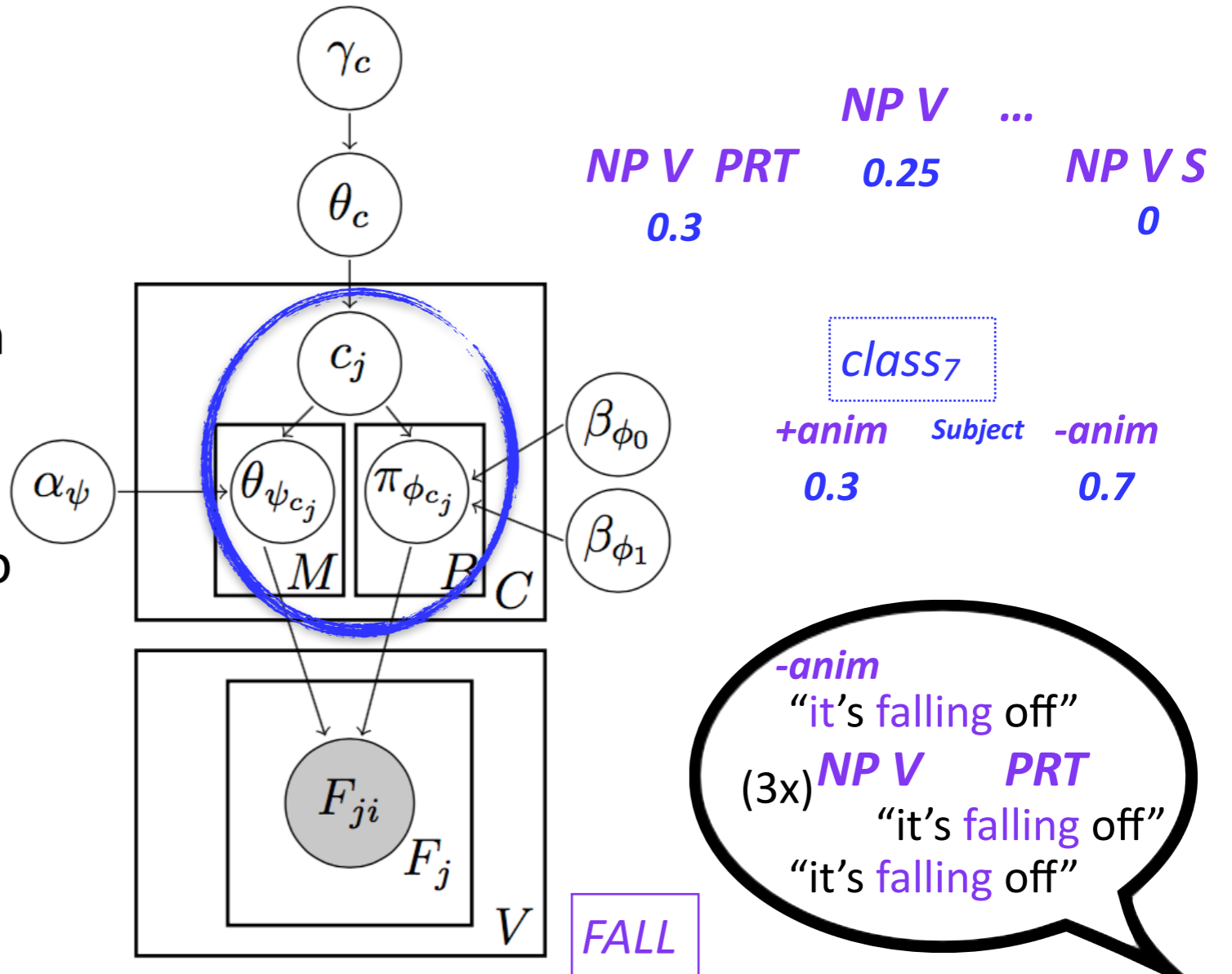

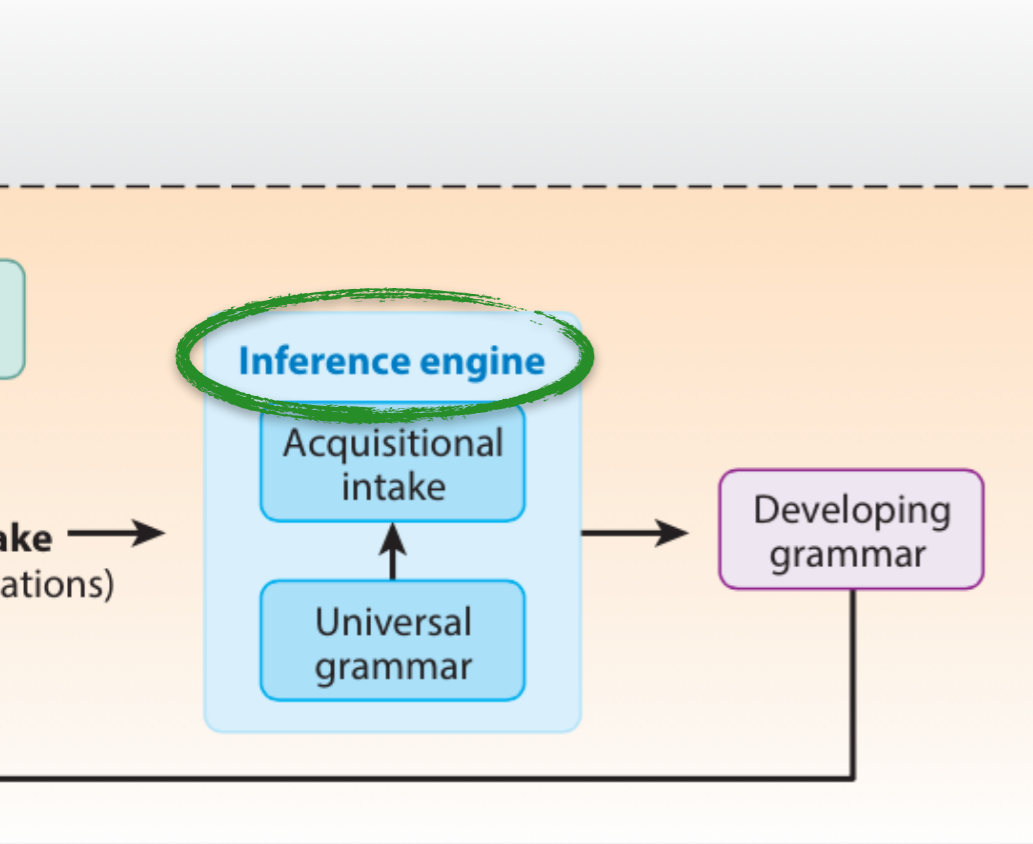

Goal: Model the developmental trajectory from 3 to 4 to 5 years old

<3yrs <4yrs <5yrs



Using the observed instances of verb usage, Bayesian inference can be used to determine

- how many classes there are
- which class each verb belongs to
- what the characteristics are of each class

Best answer: maximizes the probability of the observed data.

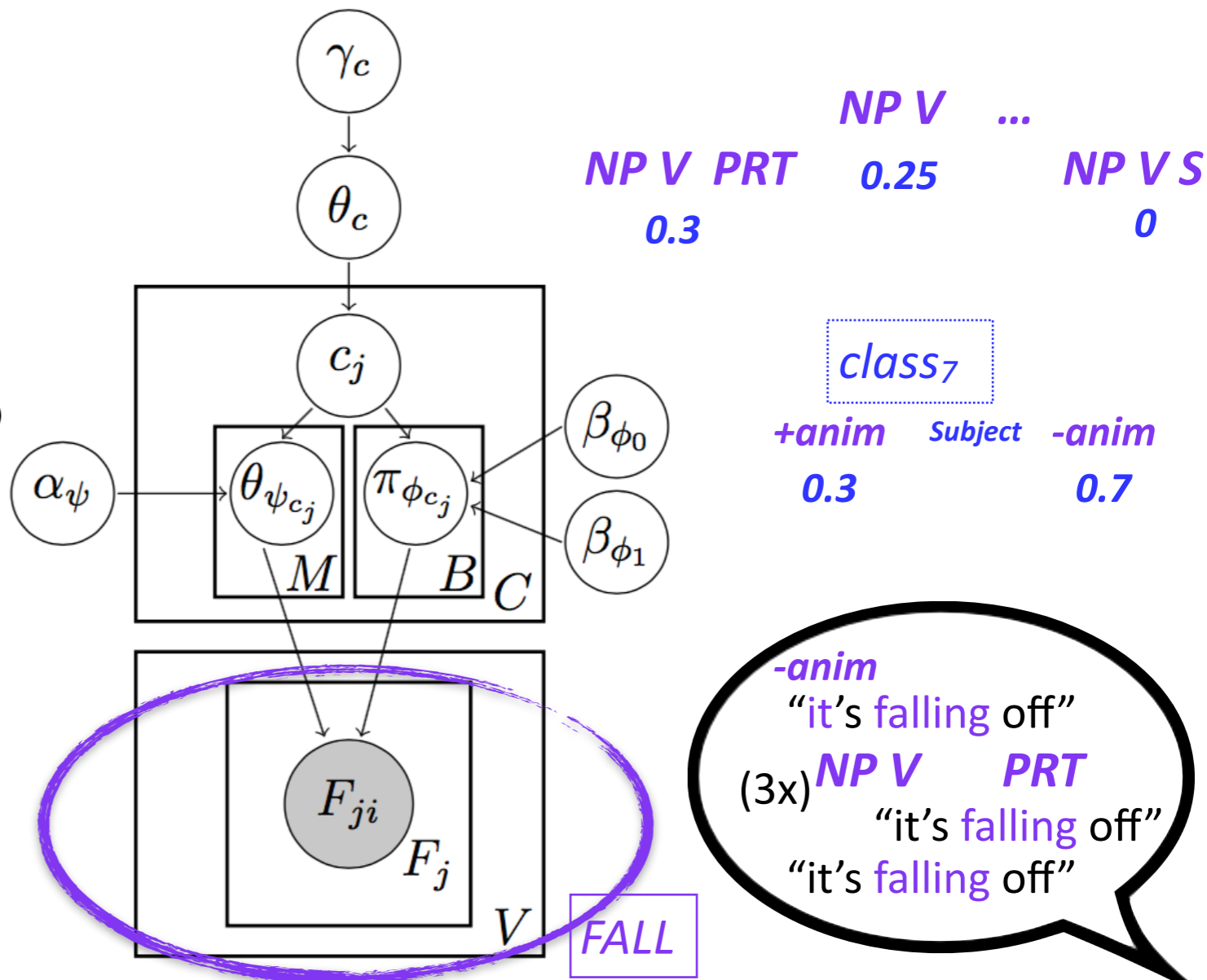

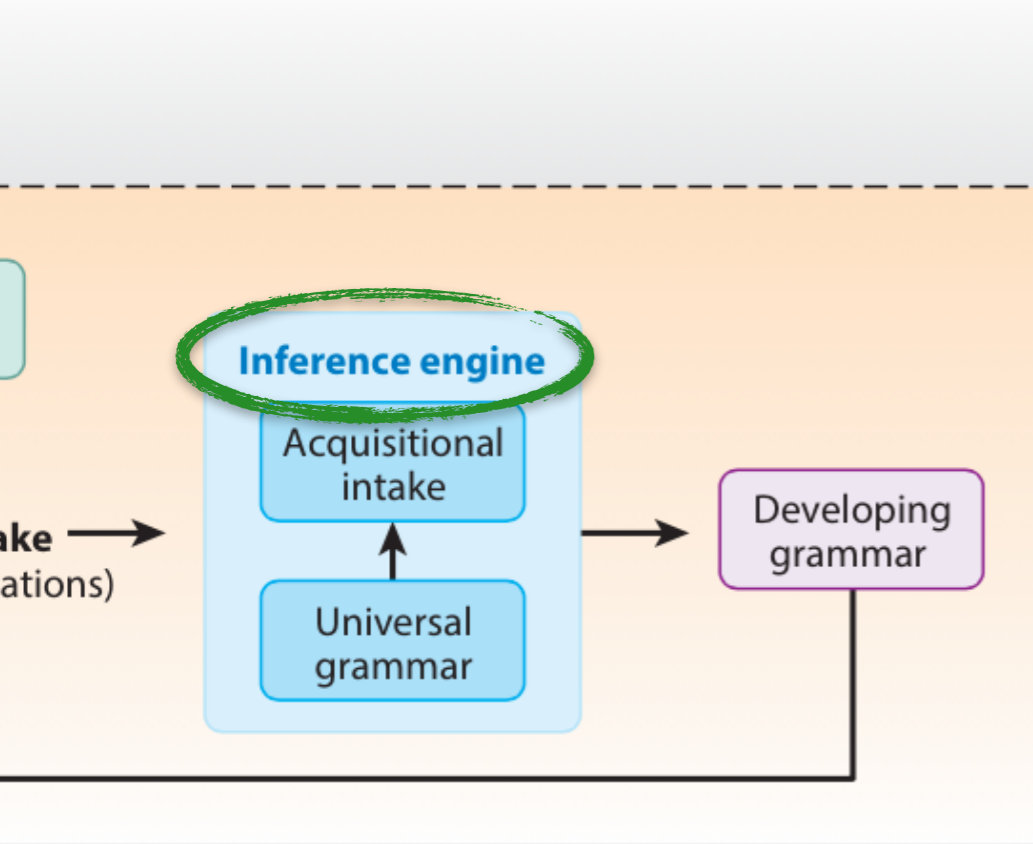

Goal: Model the developmental trajectory from 3 to 4 to 5 years old

<3yrs <4yrs <5yrs



Using the observed instances of verb usage, Bayesian inference can be used to determine

- how many classes there are
- which class each verb belongs to
- what the characteristics are of each class

$$p_{c_j} = P(c_j | c_{-j}, \gamma_c, F_{-j}, \lambda) = p_{cat_j} * p_{binary_{c_j}} * p_{multinomial_{c_j}}$$

+ Gibbs sampling

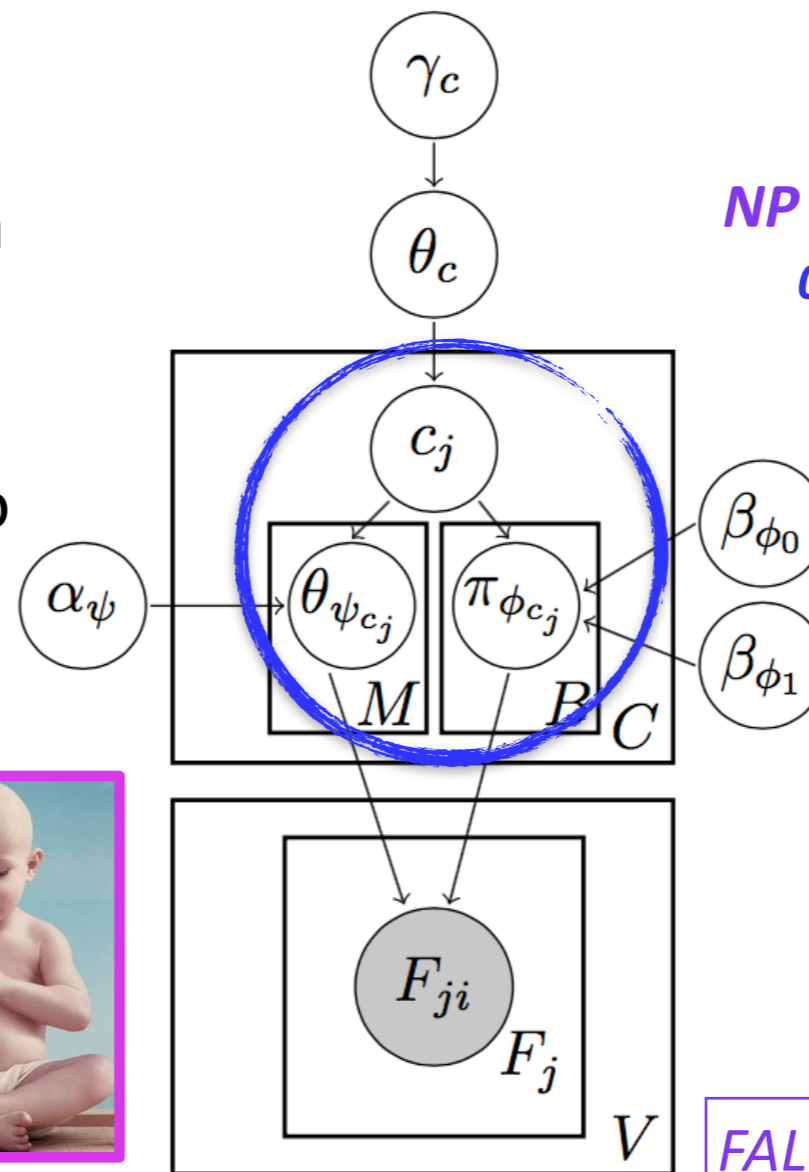

	<i>NP V</i>	...	
<i>NP V PRT</i>	0.25		<i>NP V S</i>
0.3			0

class₇

<i>+anim</i>	<i>Subject</i>	<i>-anim</i>
0.3		0.7

-anim
 "it's falling off"
 (3x) *NP V PRT*
 "it's falling off"
 "it's falling off"

FALL

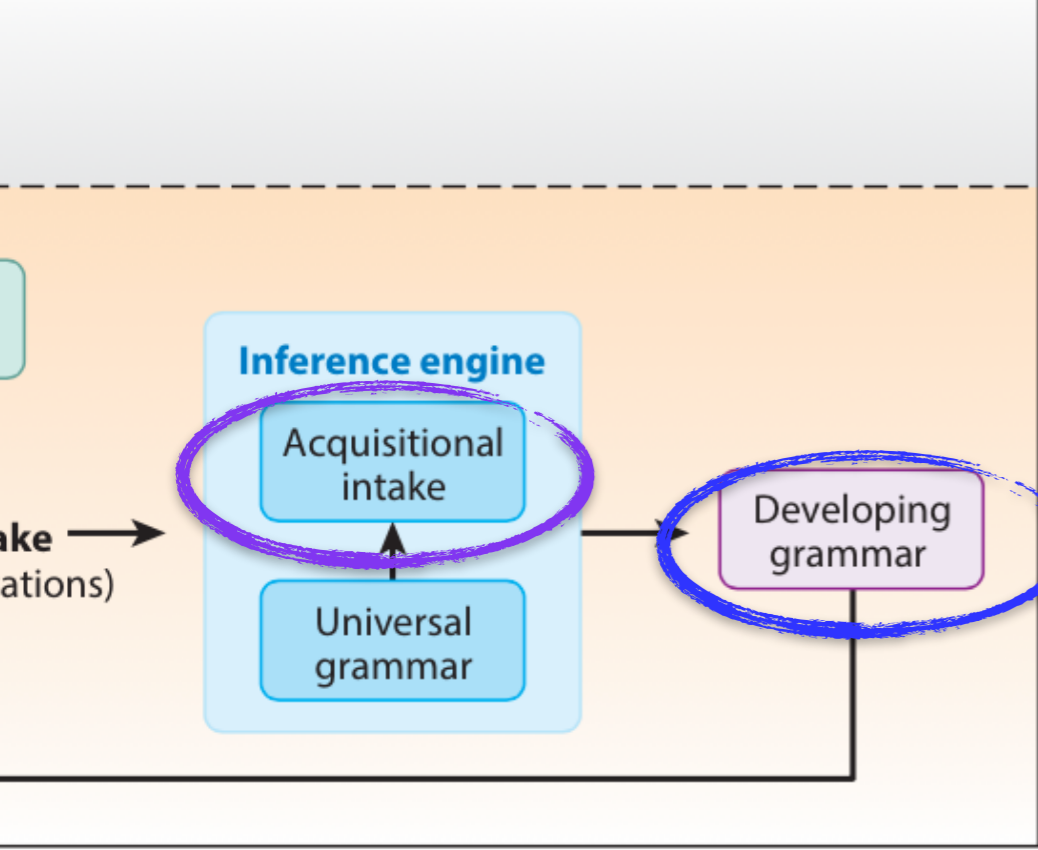

Goal: Model the developmental trajectory from 3 to 4 to 5 years old

<3yrs <4yrs <5yrs



Goal: Determine if the information provided in the modeled learner's **acquisitional intake** is **sufficient** to identify **verb classes** this way.

+surfmorph -surfmorph

UTAH
rUTAH

-expmap

+expmap

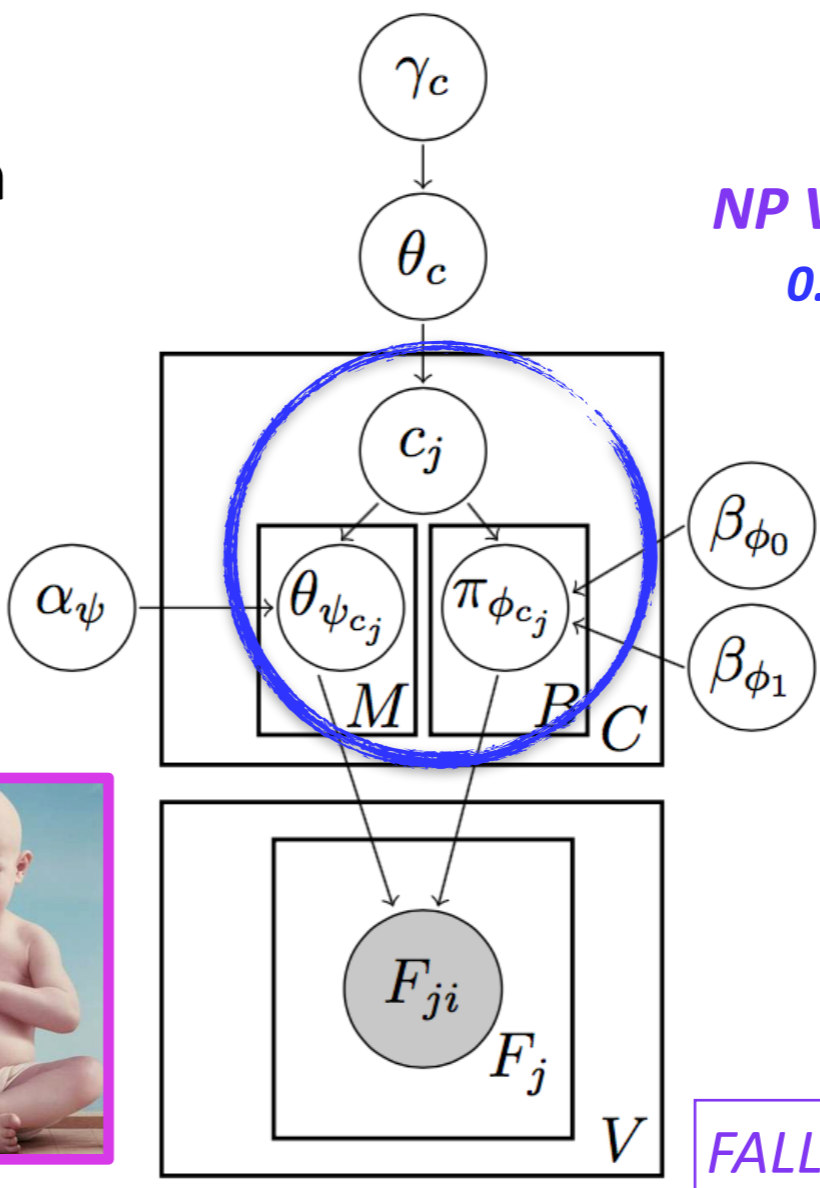

	<i>NP V</i>	...	
<i>NP V PRT</i>	0.25		<i>NP V S</i>
0.3			0

class₇

+anim	Subject	-anim
0.3		0.7

-anim
"it's falling off"
(3x) *NP V PRT*
"it's falling off"
"it's falling off"

FALL

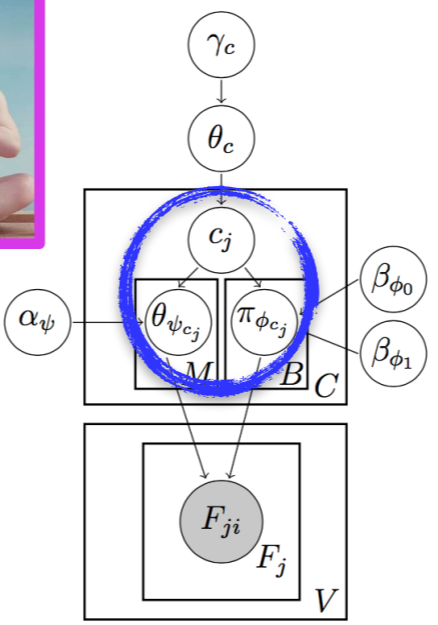
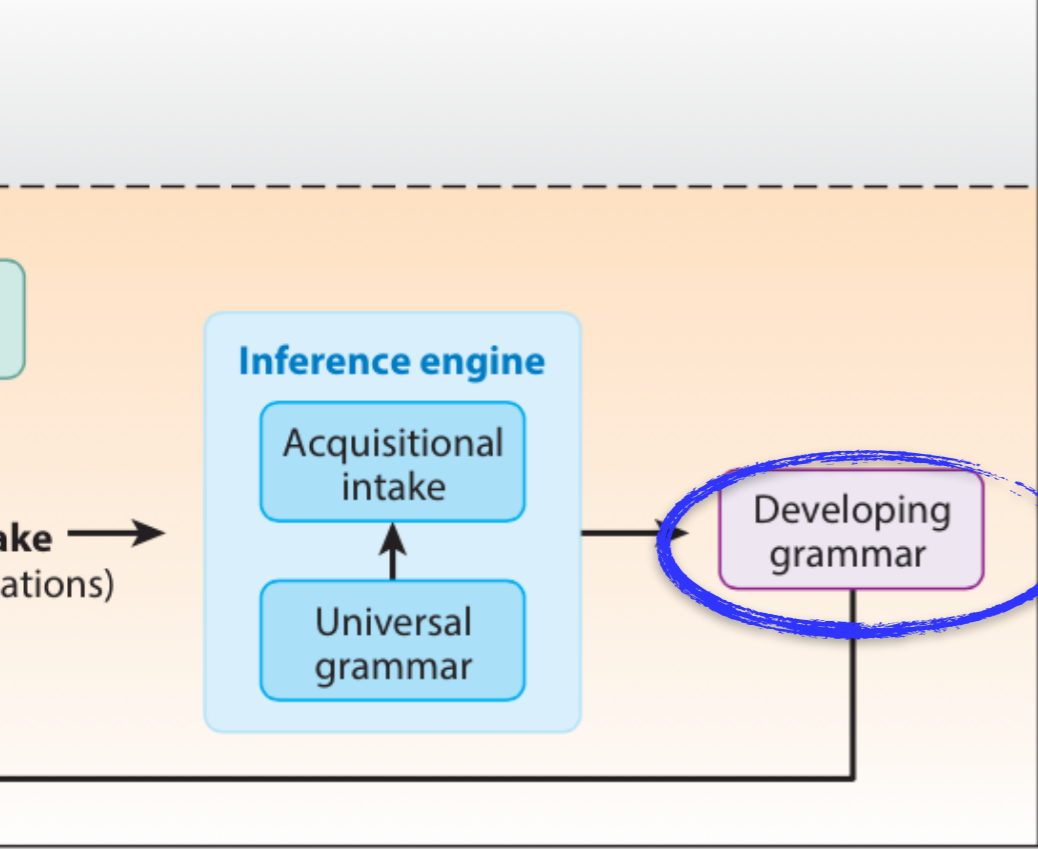

Goal: Model the developmental trajectory from 3 to 4 to 5 years old

<3yrs <4yrs <5yrs

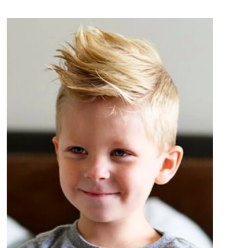

verb classes

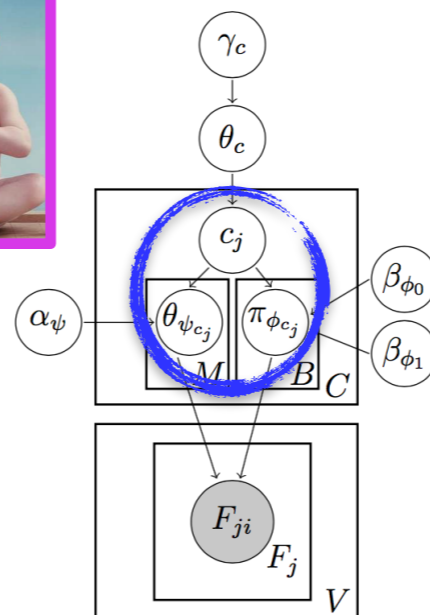
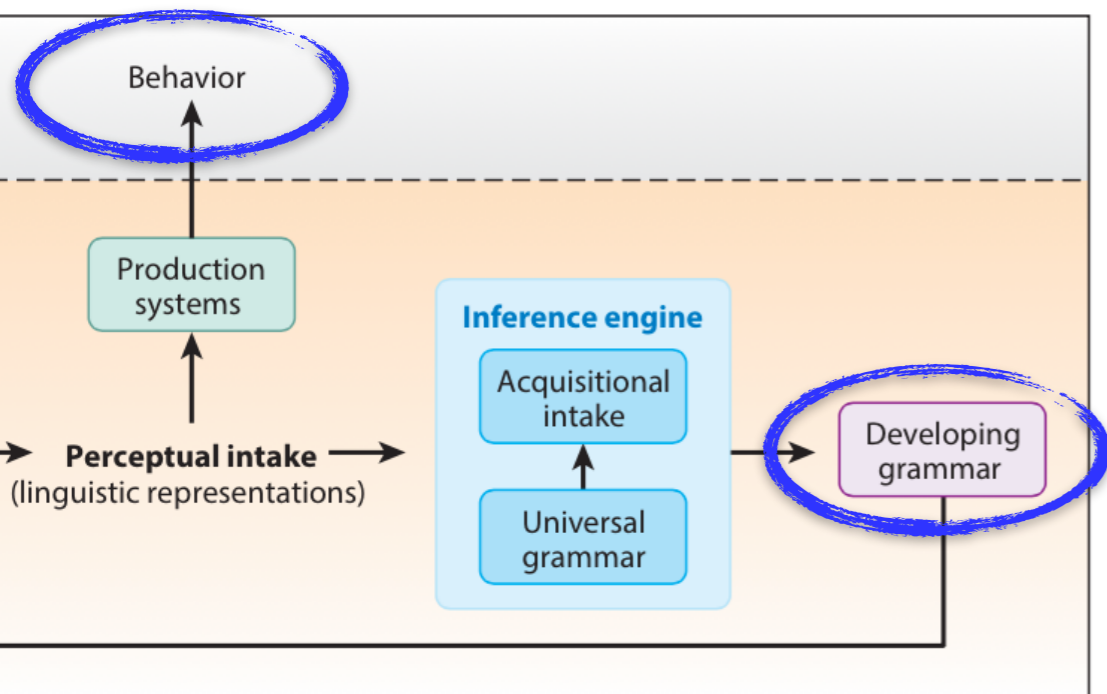

Goal: Model the developmental trajectory from 3 to 4 to 5 years old

<3yrs

<4yrs

<5yrs



verb classes

Survey of 32 experimental studies on children's production and comprehension of specific verbs



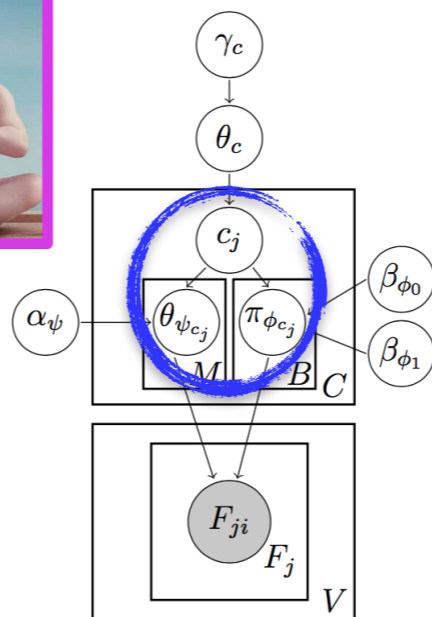
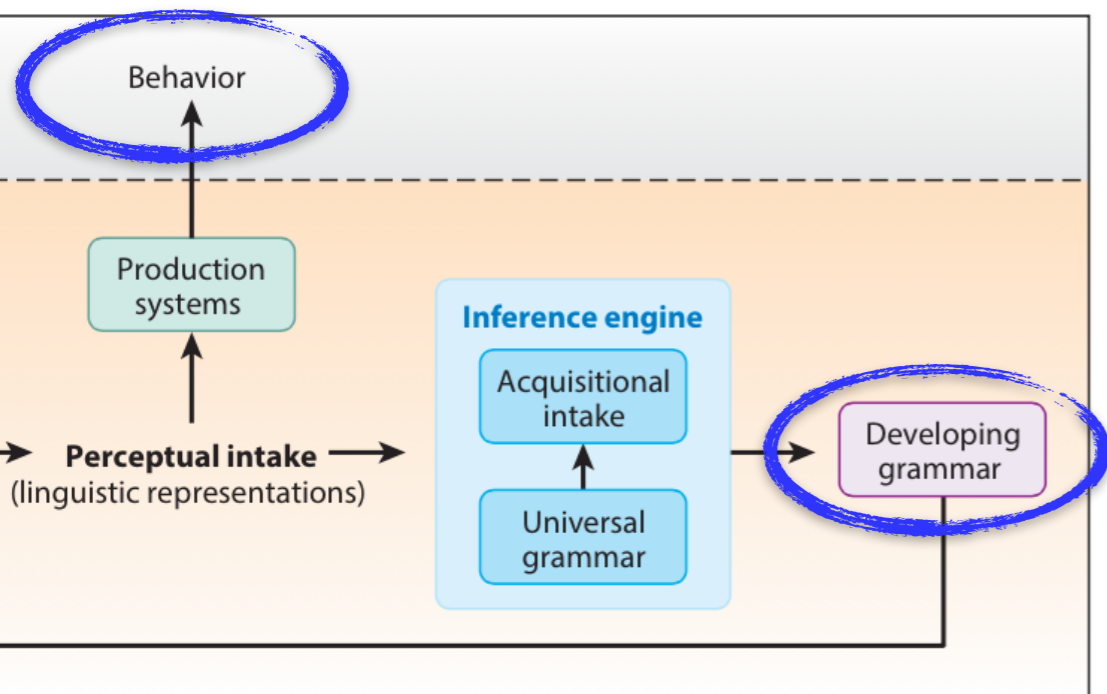

Goal: Model the developmental trajectory from 3 to 4 to 5 years old

<3yrs <4yrs <5yrs



verb classes

Survey of 32 experimental studies on children's production and comprehension of specific verbs

Yields 12 verb behaviors



+/-passive

+unaccusative

+ditransitive

+control-object

+raising-object

+raising-subject

+control-subject

+that-comp

+whether/if-comp

+subject-experiencer

+object-experiencer

+non-finite to-comp

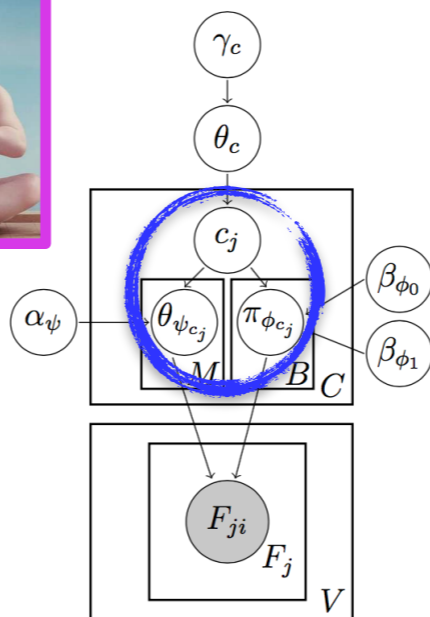
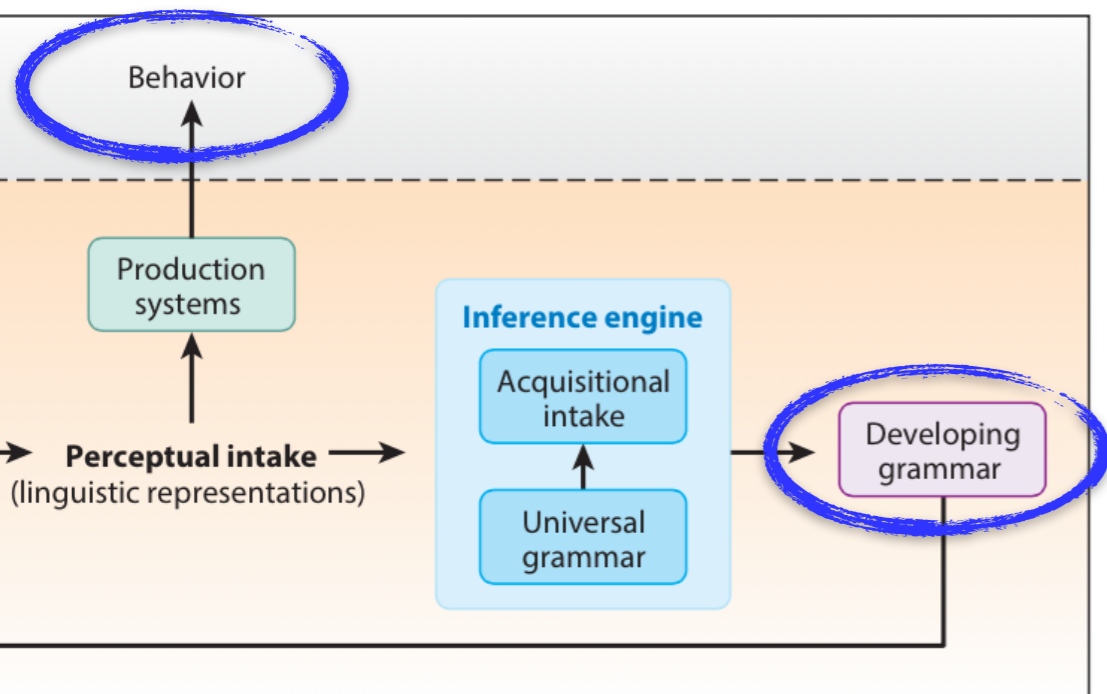

Goal: Model the developmental trajectory from 3 to 4 to 5 years old

<3yrs

<4yrs

<5yrs



These verb behaviors yield a number of verb classes at each age

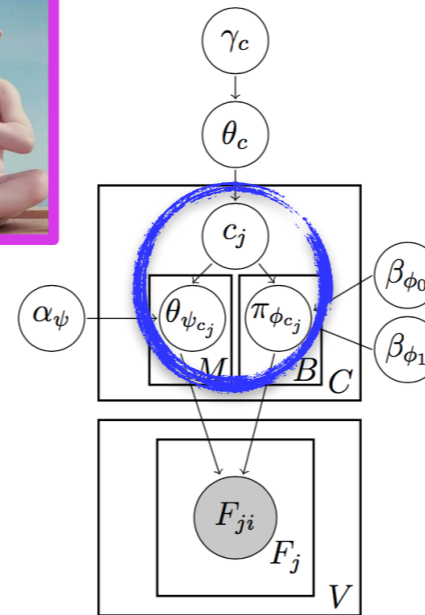
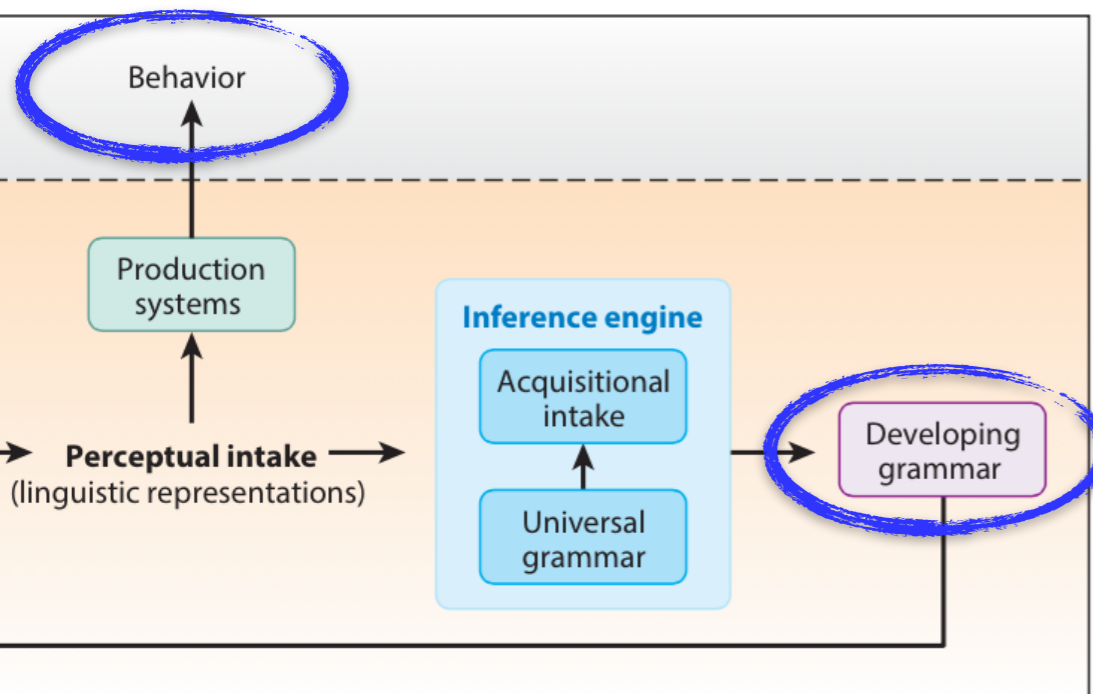

Goal: Model the developmental trajectory from 3 to 4 to 5 years old

<4yrs

<5yrs

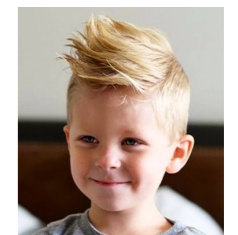

These verb behaviors yield a number of verb classes at each age

Example classes

<3yrs



[+passive]: carry, chase, crash, drop, eat, hit, hold, hurt, jump, kick, kiss, knock, lick, punch, push, scratch, shake, turn, wash, watch

[-passive]: believe, remember

[+non-finite to]: ask, have, need, start, suppose, teach, try, use, want

[+that-comp]: bet, hope, think, wish

[+passive, +non-finite to]: like

[+passive, +that-comp]: see

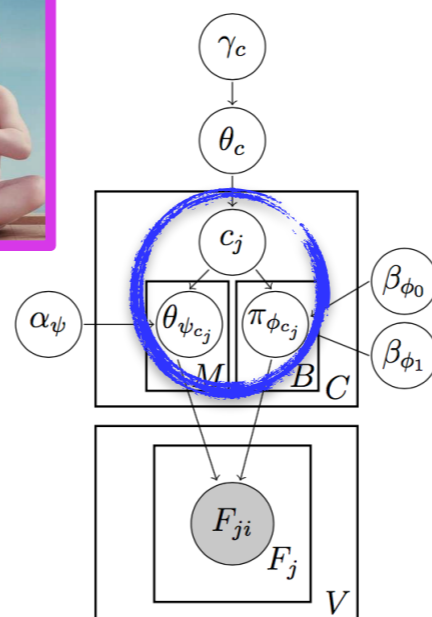
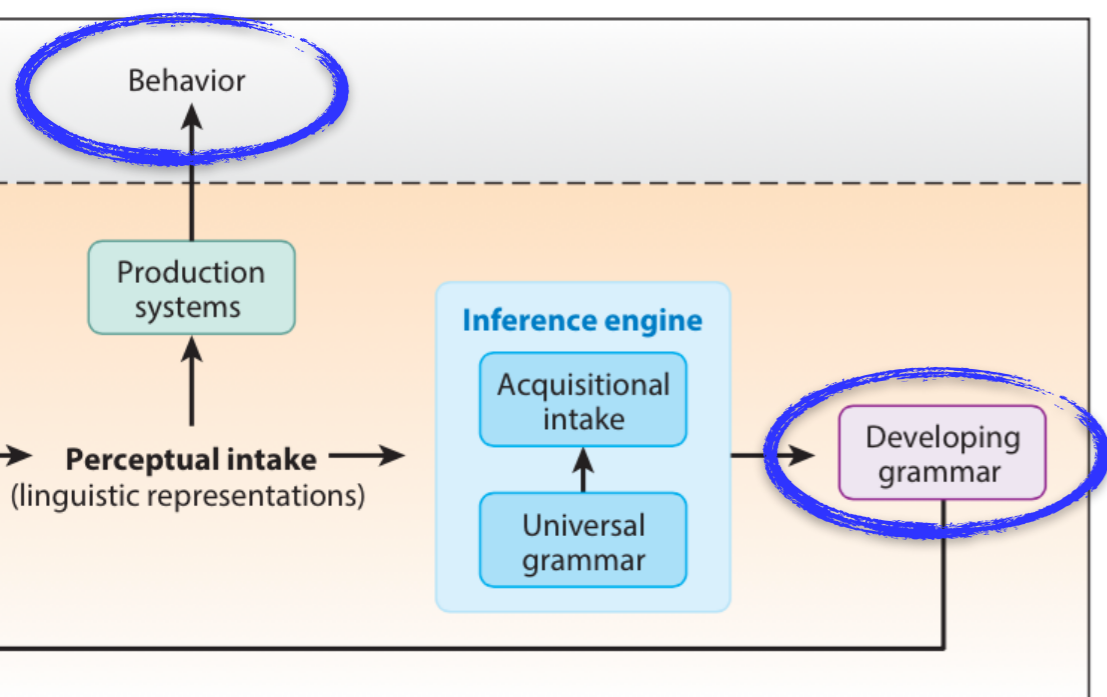

Goal: Model the developmental trajectory from 3 to 4 to 5 years old



These verb behaviors yield a number of verb classes at each age

<4yrs



Example classes

[+passive]: bite, bump, carry, chase, crash, drop, find, hit, hold, hurt, jump, kick, kill, kiss, knock, lick, pull, punch, push, ride, scratch, shake, shoot, turn, wash, watch

[-passive]: believe, remember

[+that-comp]: bet, hope, think, wish

[+non-finite to, +raising-obj]: need

[+non-finite to, +raising-obj, +control-subj]: want

[+passive, +non-finite to, +psych-subj]: like

[+passive, +that-comp]: see

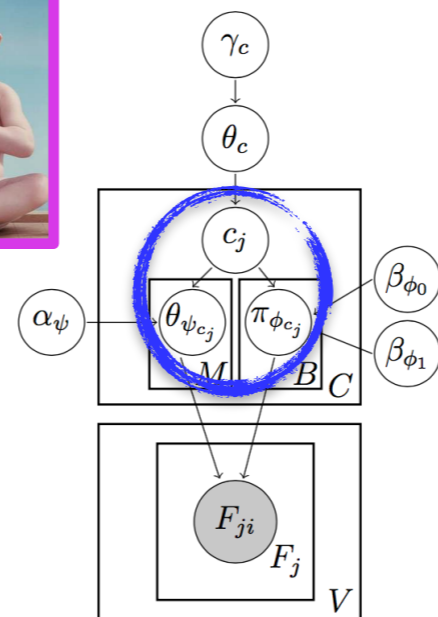
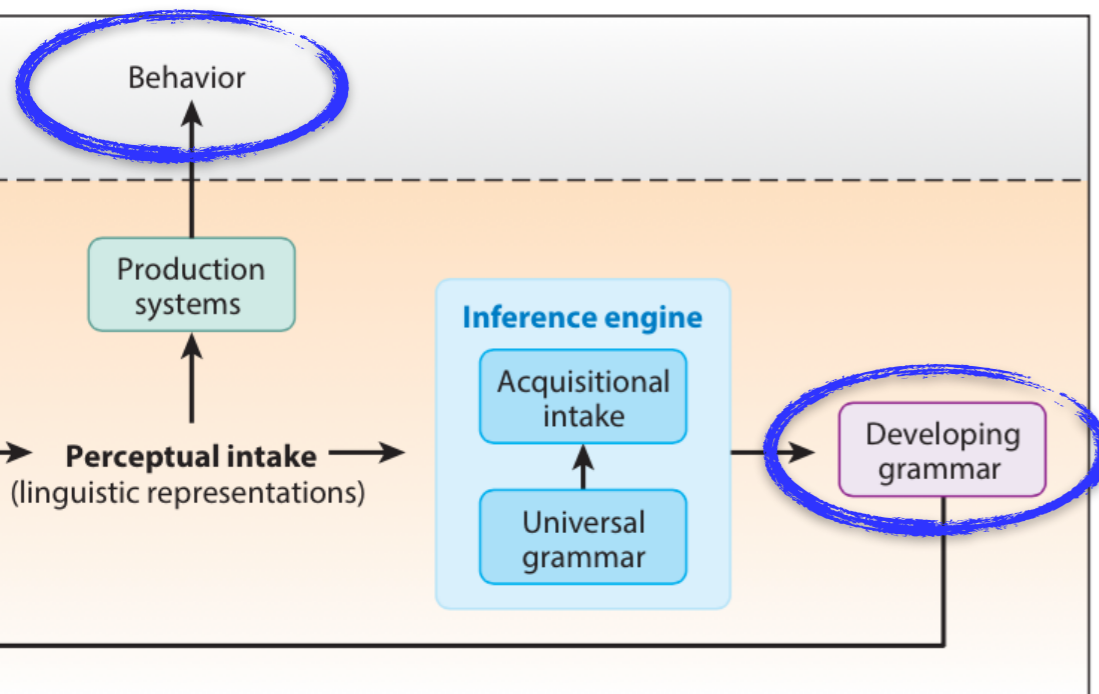

Goal: Model the developmental trajectory from 3 to 4 to 5 years old

<3yrs

<4yrs



These verb behaviors yield a number of verb classes at each age

<5yrs



Example classes

[+passive]: bite, bump, carry, chase, crash, drop, find, hit, hold, hurt, jump, kick, kill, kiss, knock, lick pull, push, ride, scratch, shake, shoot, turn, wash, watch

[-passive]: believe, remember

[+that-comp]: bet, dream, guess, hope, lie, pretend, think, wish

[+non-finite to, +raising-obj]: need

[+non-finite to, +raising-obj, +control-subj]: want

[+passive, +non-finite to, +psych-subj]: like

[+passive, +that-comp, +whether/if-comp]: see

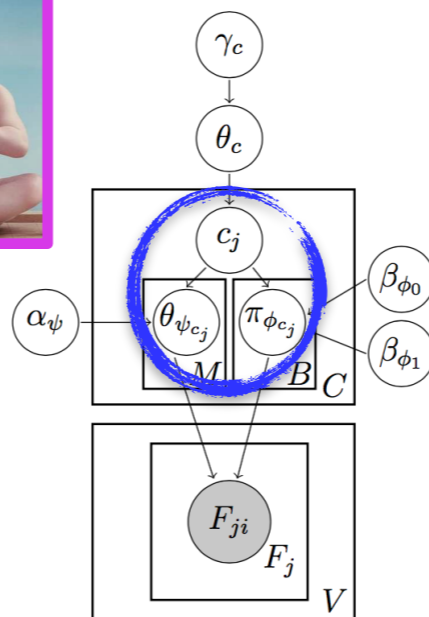
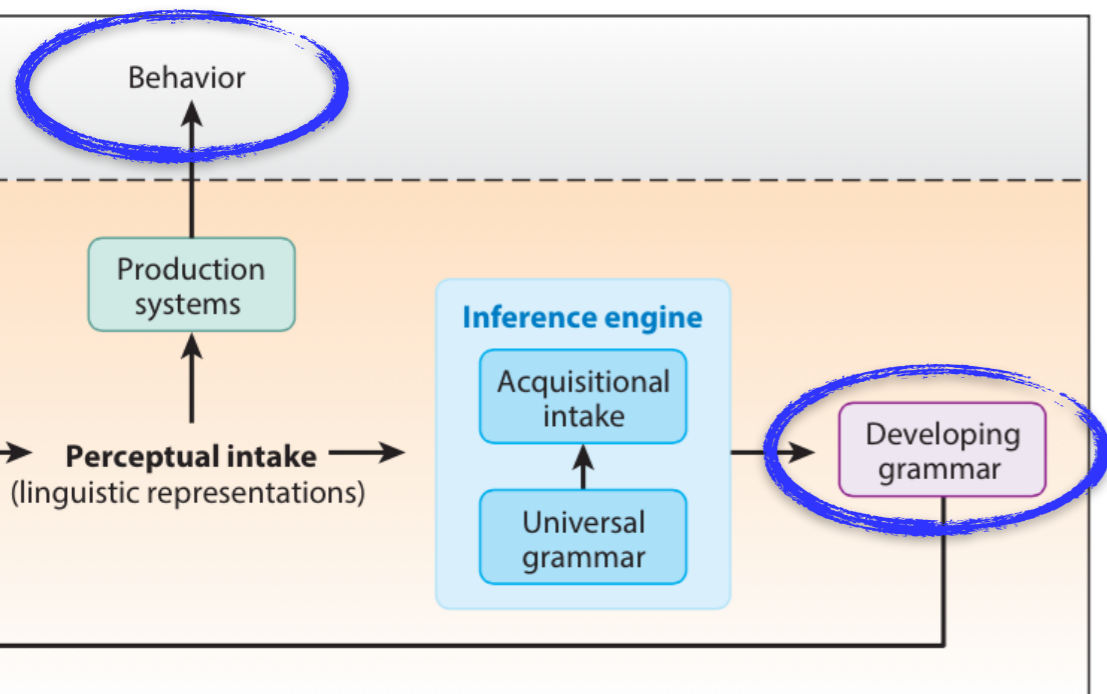

Goal: Model the developmental trajectory from 3 to 4 to 5 years old

These verb behaviors yield a number of verb classes at each age

<3yrs



15 classes of 60 verbs total

<4yrs



23 classes of 76 verbs total

<5yrs



25 classes of 84 verbs total

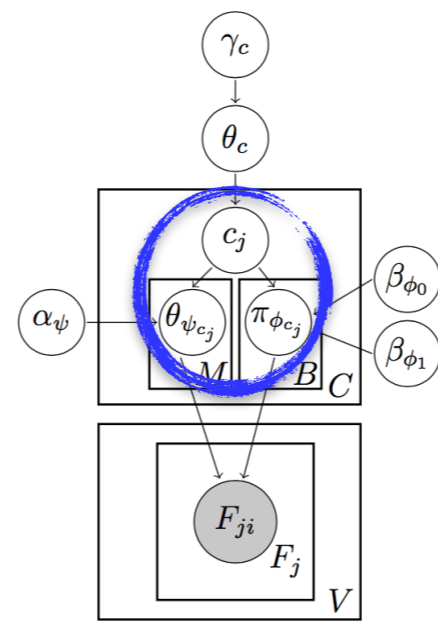
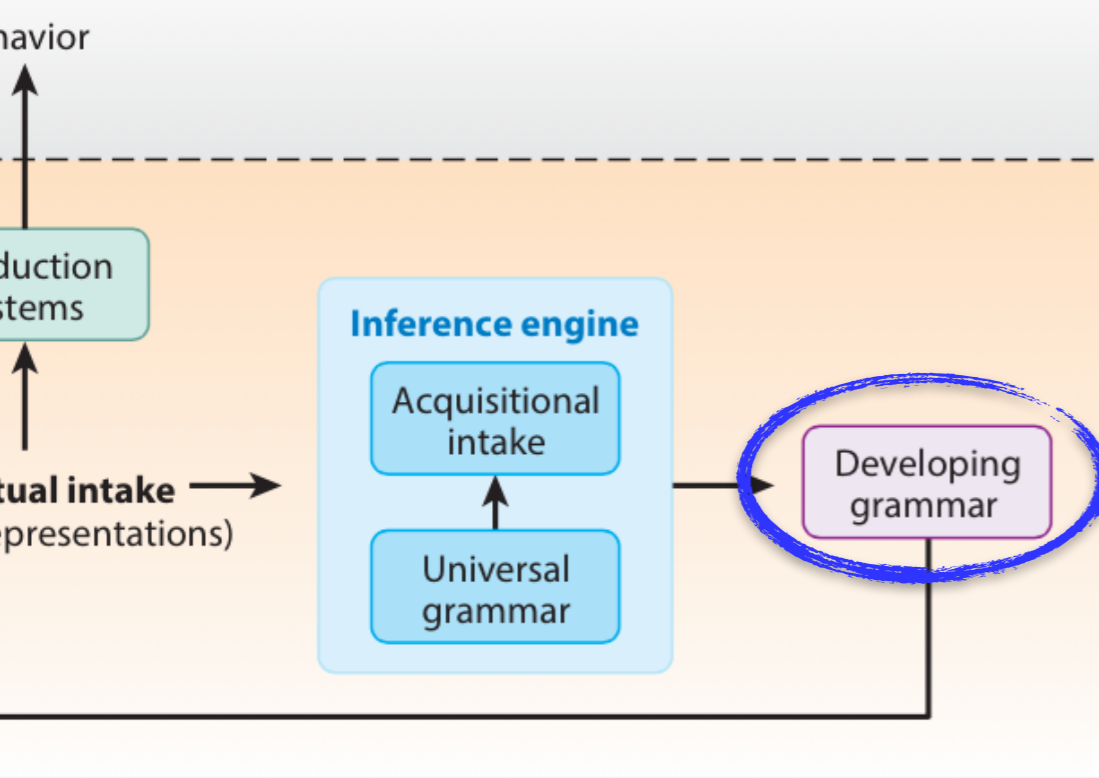

Goal: Model the developmental trajectory from 3 to 4 to 5 years old

<3yrs

<4yrs

<5yrs

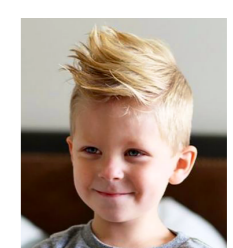

15 classes

23 classes

25 classes

Evaluation:

How well did the modeled learner do at finding these verb classes?



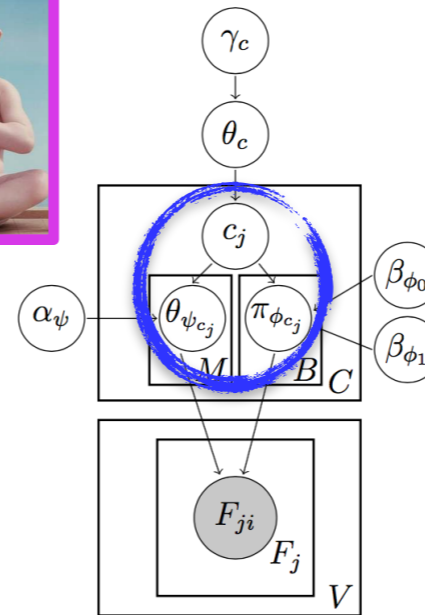
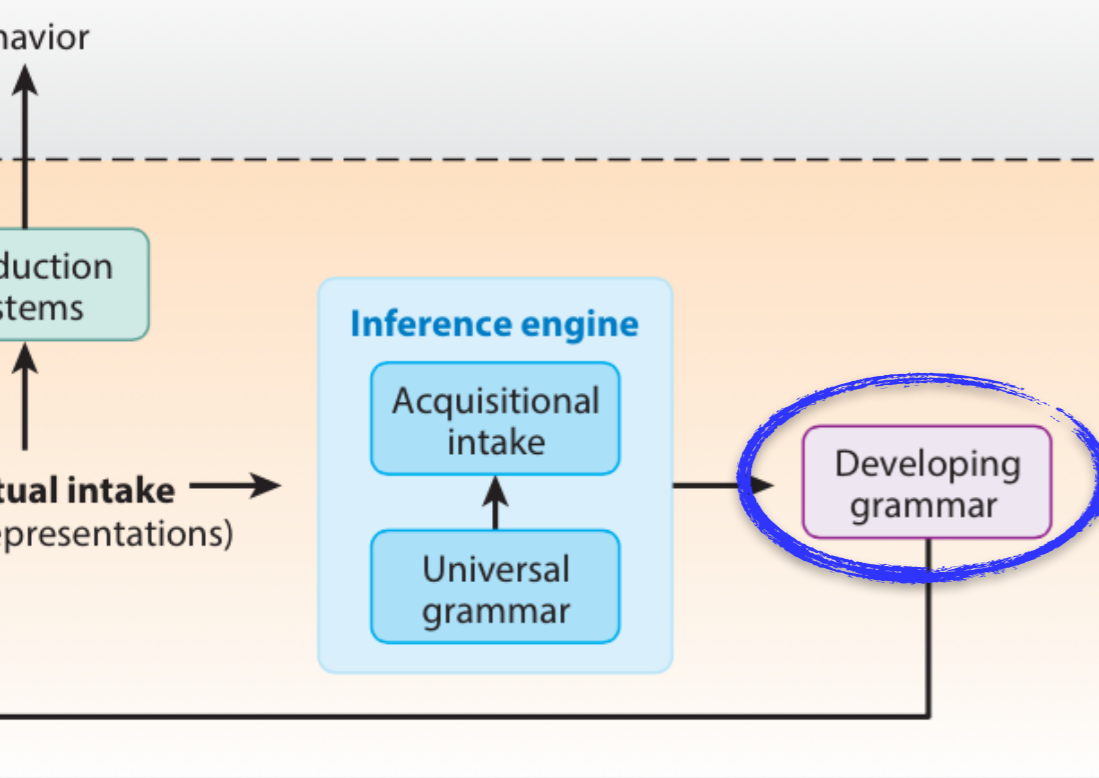

Goal: Model the developmental trajectory from 3 to 4 to 5 years old

<3yrs

<4yrs

<5yrs



15 classes



23 classes

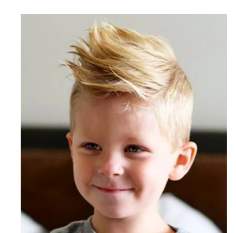

25 classes

Implementation:
Random Index



$$0.0 \leq RI \leq 1.0$$



Intuition: Get credit for putting things together that belong together and keeping things apart that don't belong together.

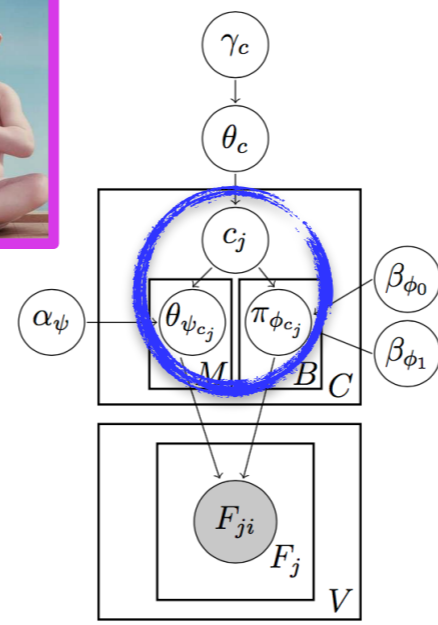
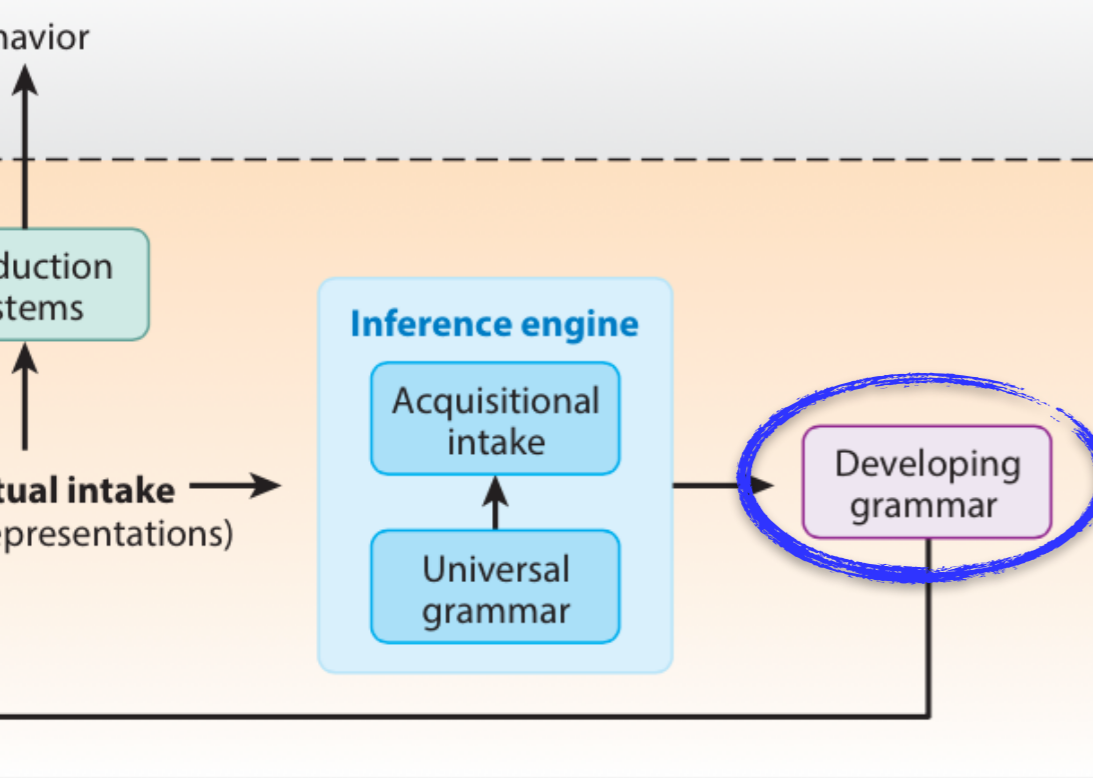

Goal: Model the developmental trajectory from 3 to 4 to 5 years old

<3yrs

<4yrs

<5yrs

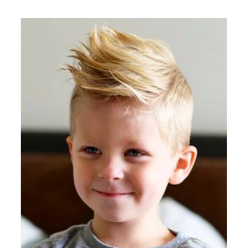

15 classes

23 classes

25 classes

Implementation:
Random Index

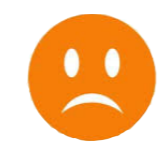

$$0.0 \leq RI \leq 1.0$$

For each pair of verbs in the inferred classes: $verb_i$ $verb_j$



		Inferred Class	
		Same class	Different class
True	Same class	True Positive	False Negative
	Different class	False Positive	True Negative

Intuition: Get credit for putting things together that belong together and keeping things apart that don't belong together.

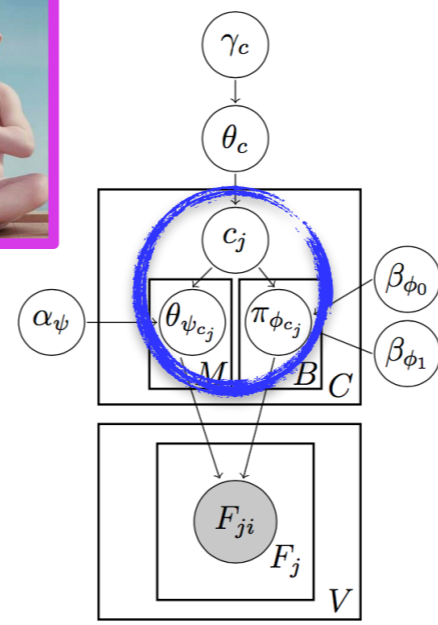
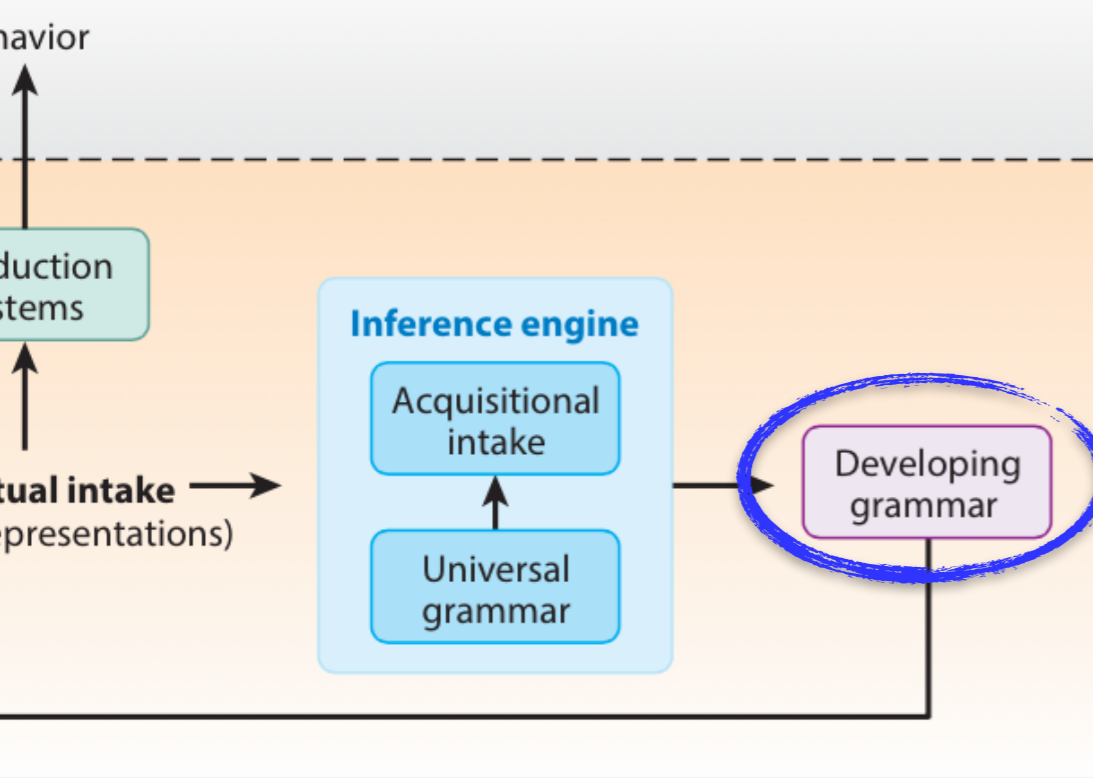

Goal: Model the developmental trajectory from 3 to 4 to 5 years old

<3yrs

<4yrs

<5yrs

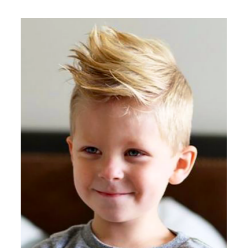

15 classes

23 classes

25 classes

Implementation:
Random Index



$$0.0 \leq RI \leq 1.0$$

$$\frac{\text{True Positives} + \text{True Negatives}}{\text{True Positives} + \text{True Negatives} + \text{False Positives} + \text{False Negatives}}$$

For each pair of verbs in $\text{verb}_i \text{ verb}_j$ the inferred classes:

		Inferred Class	
		Same class	Different class
True	Same class	True Positive	False Negative
	Different class	False Positive	True Negative



Intuition: Get credit for putting things together that belong together and keeping things apart that don't belong together.

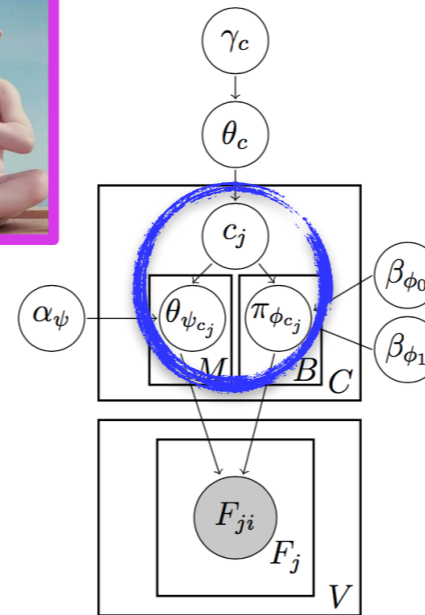
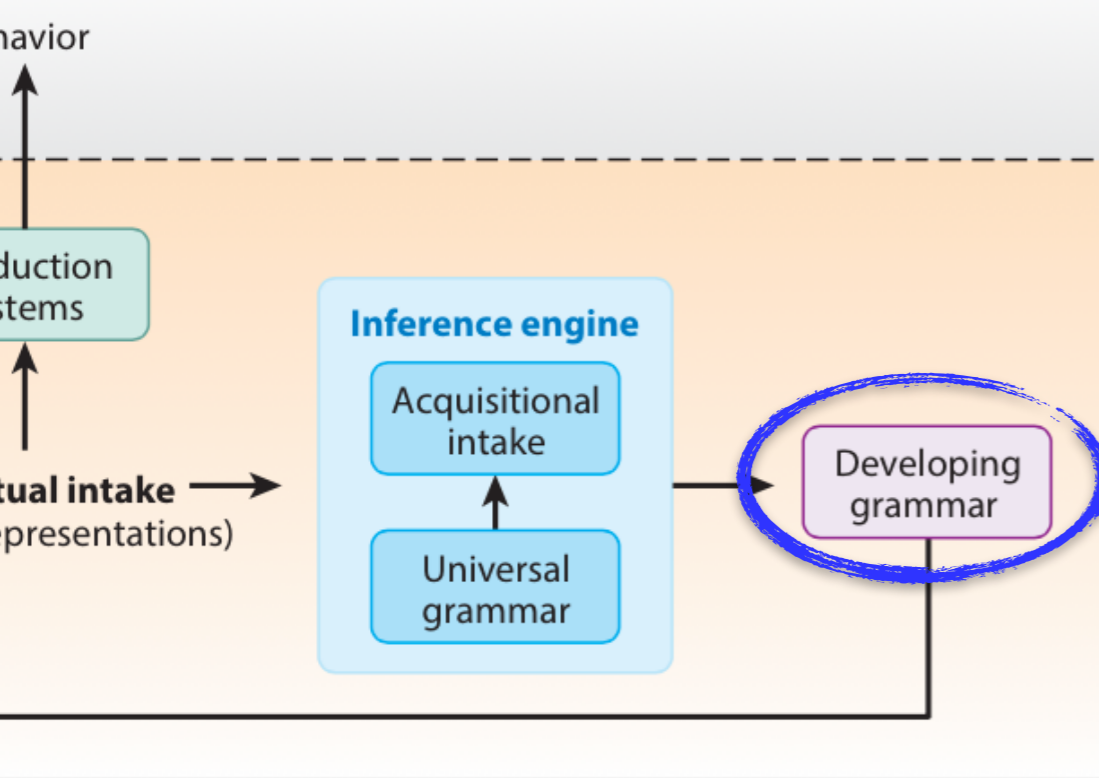

Goal: Model the developmental trajectory from 3 to 4 to 5 years old

<3yrs

<4yrs

<5yrs



15 classes



23 classes

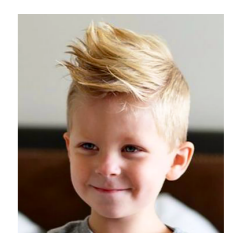

25 classes

Implementation:
Random Index



$$0.0 \leq RI \leq 1.0$$



Intuition: Get credit for putting things together that belong together and keeping things apart that don't belong together.

But how do we know we're doing better than chance?



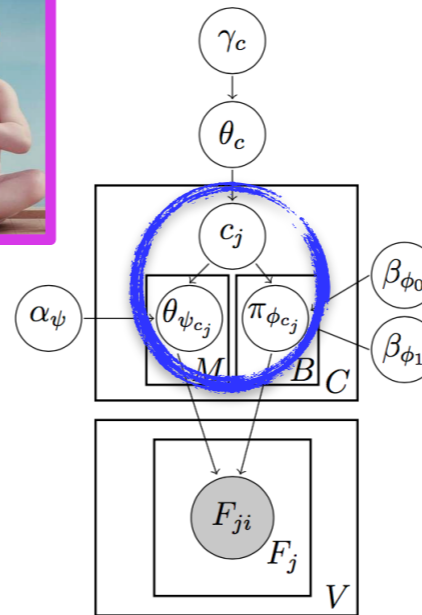
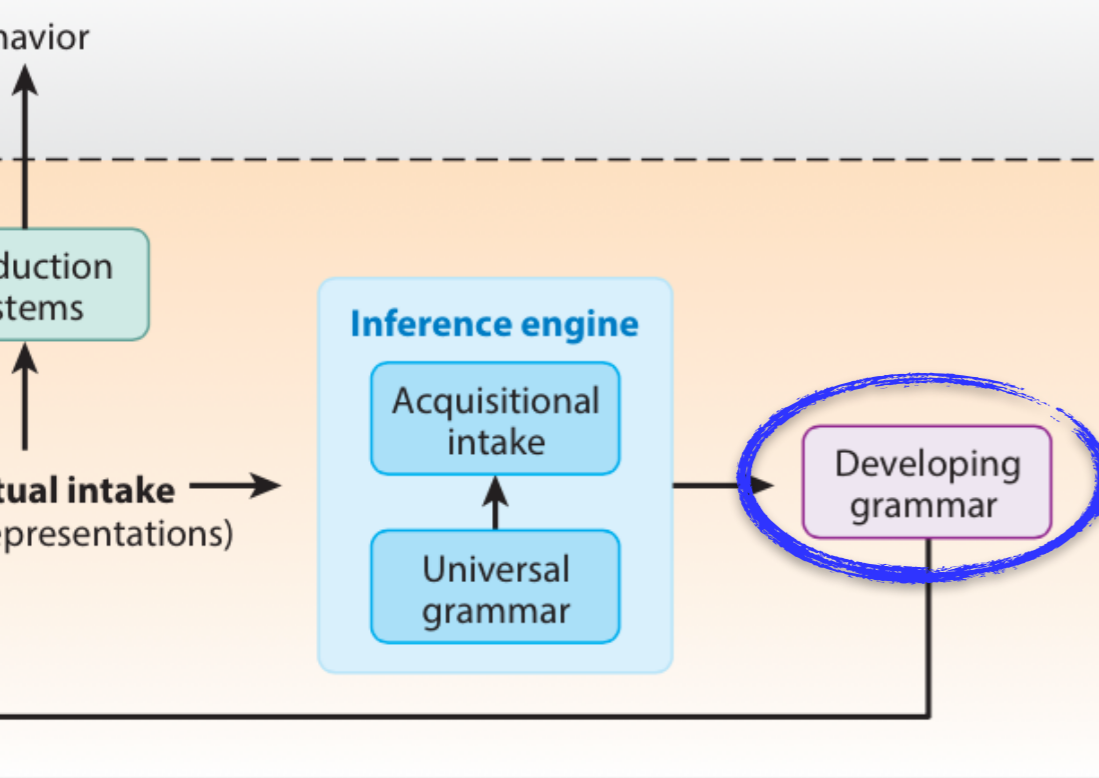

Goal: Model the developmental trajectory from 3 to 4 to 5 years old

<3yrs

<4yrs

<5yrs



15 classes



23 classes

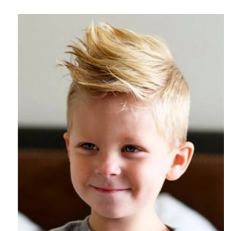

25 classes

Implementation 1:
Bootstrapped confidence intervals for RI, based on class distribution

- 😊 RI > 99% = better than chance
- 😐 RI in between = chance performance
- 😞 RI < 1% = worse than chance

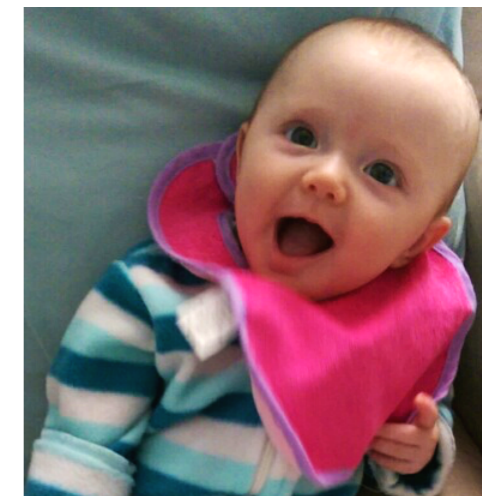

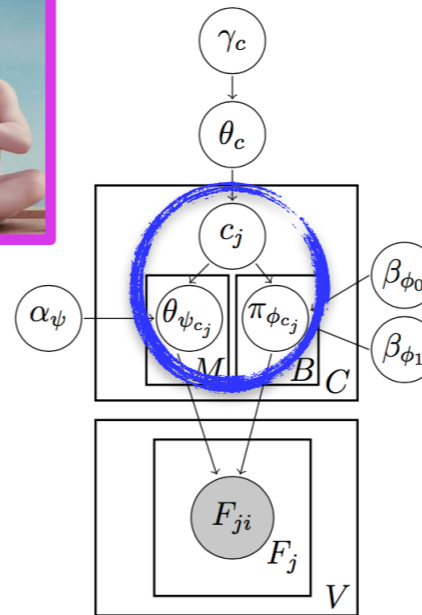
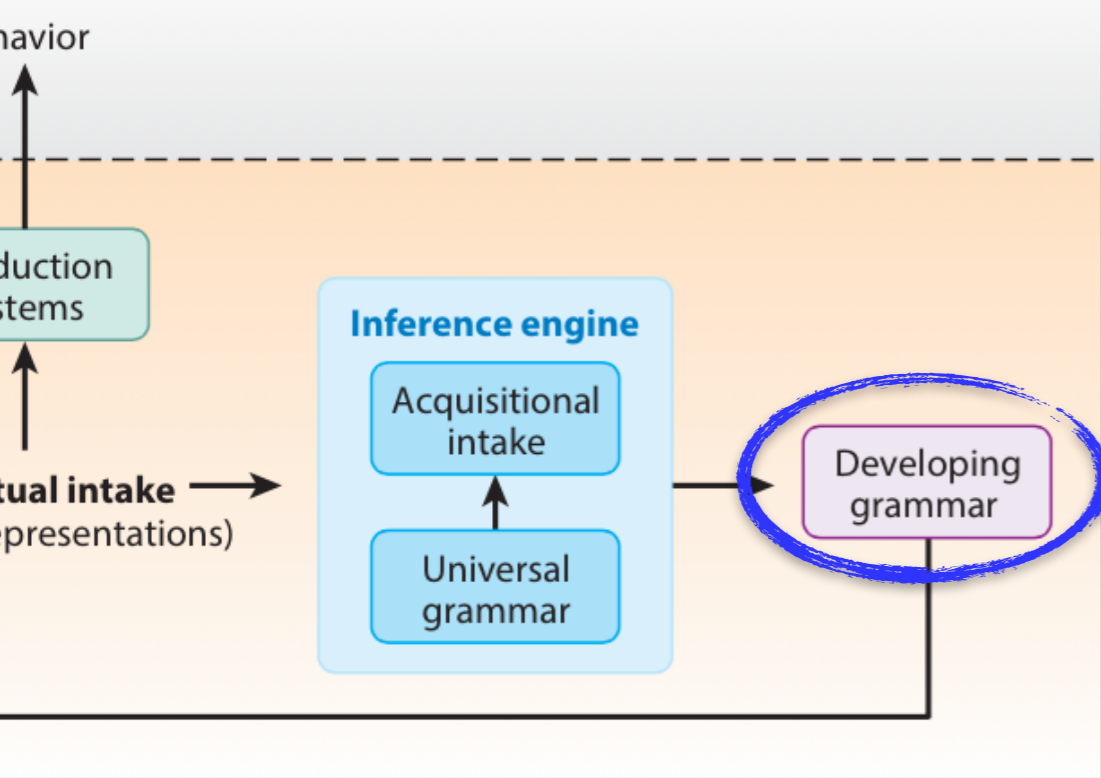

Goal: Model the developmental trajectory from 3 to 4 to 5 years old

<3yrs

<4yrs

<5yrs



15 classes



23 classes

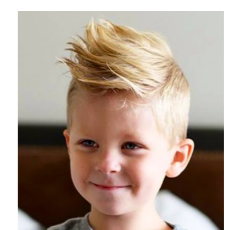

25 classes

Implementation 2:

Adjusted Random Index



$$-1.0 \leq \text{ARI} \leq 1.0$$

Compared against the expected value of the Random Index:

1.0 = perfect classification

>0 = better than chance

0 = chance performance

<0 = worse than chance

-1.0 = perfectly awful classification

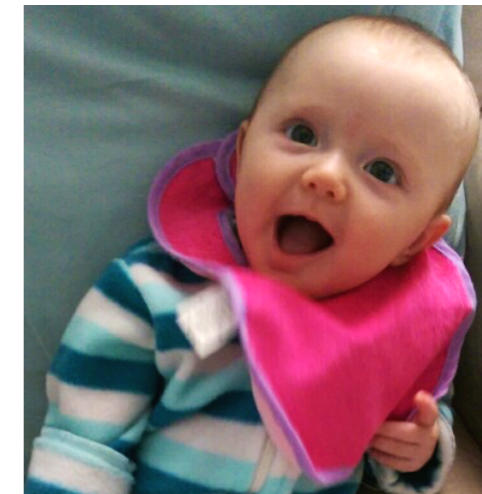

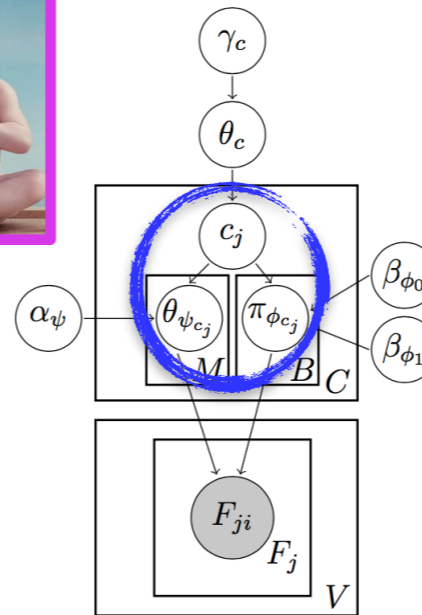
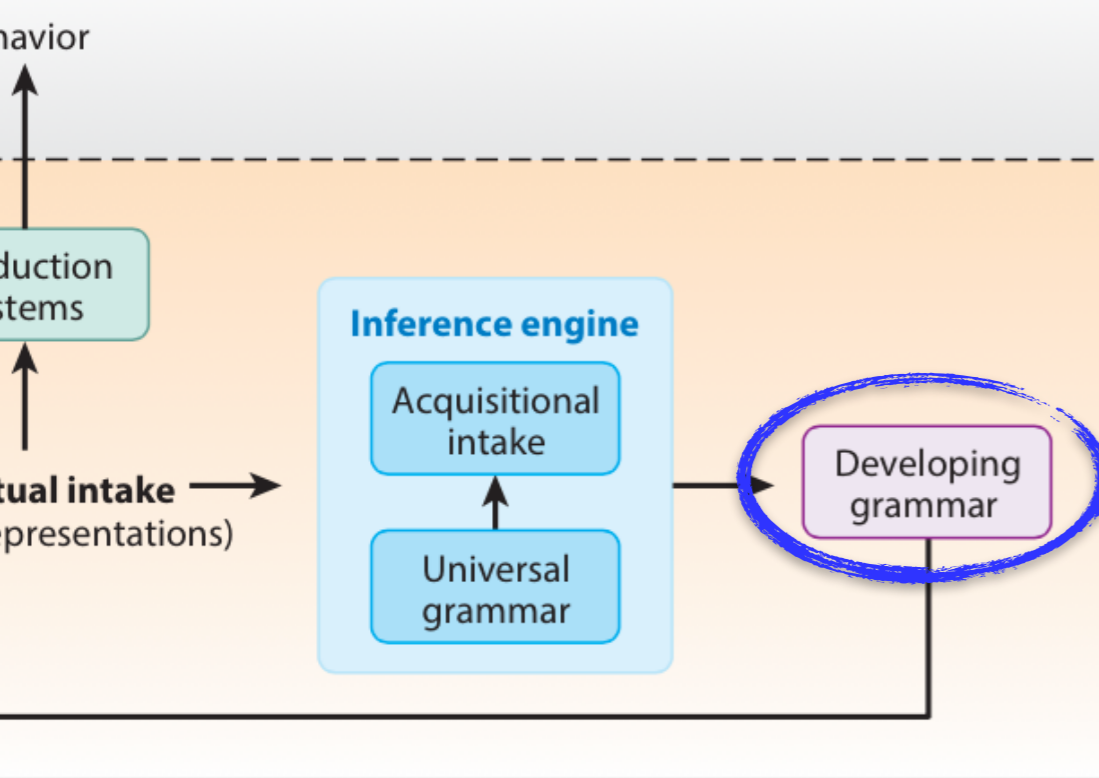

Goal: Model the developmental trajectory from 3 to 4 to 5 years old

<3yrs

<4yrs

<5yrs

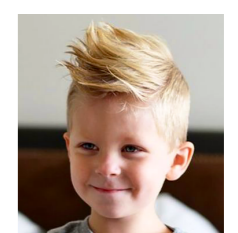

15 classes

23 classes

25 classes

Implementation 1:

Bootstrapped confidence intervals for RI, based on class distribution

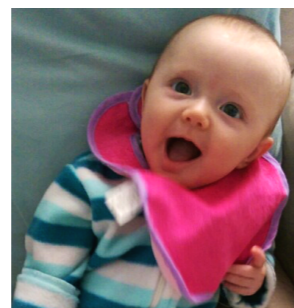

Look for agreement between these two measures as signal of significant difference

RI > 99% = better than chance



1.0 = perfect classification

>0 = better than chance

RI in between = chance performance



0 = chance performance

RI < 1% = worse than chance



<0 = worse than chance

-1.0 = perfectly awful classification

Today's plan

Results & implications

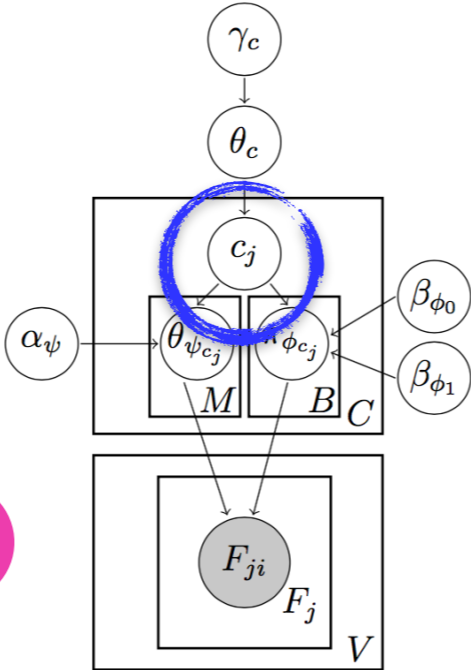

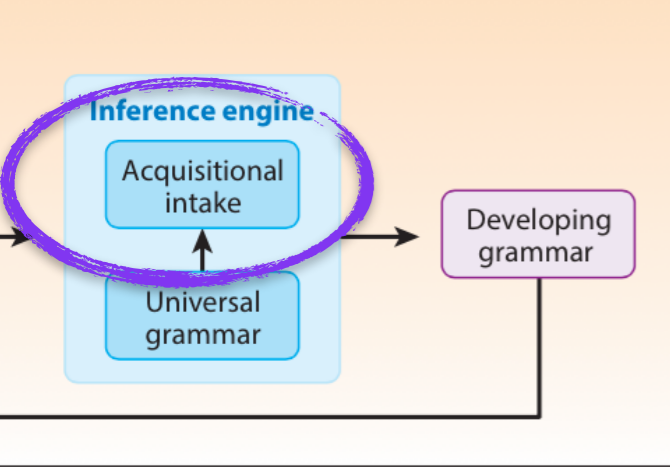

significantly better
than chance

3yrs



-surfmorph
rUTAH

4yrs



+surfmorph
UTAH
-expmap

5yrs

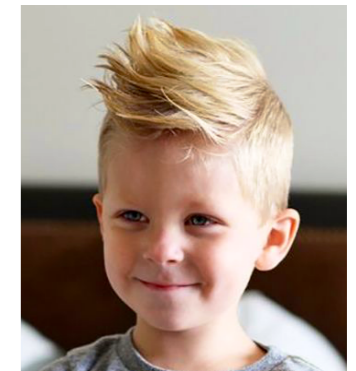

+surfmorph
UTAH rUTAH
+expmap

This is the first articulation of the trajectory of learning assumptions children may have that causes them to group verbs into useful classes the way we observe.

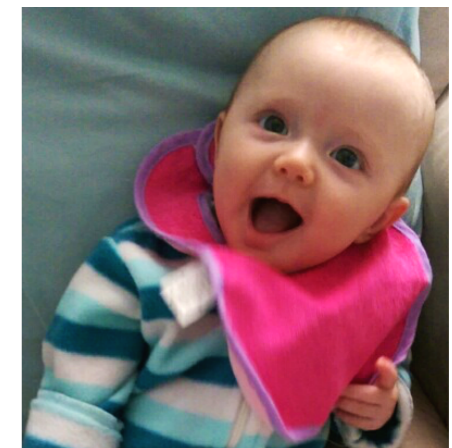

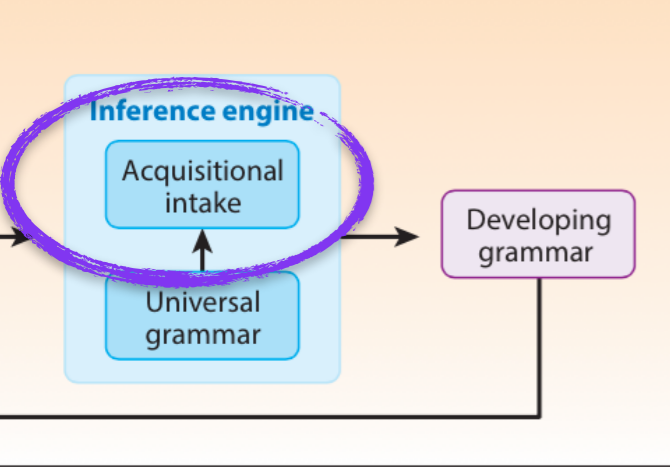

3yrs



-surfmorph

rUTAH

NP ____ S_{nonfinite}

4yrs



+surfmorph

UTAH
-expmap

NP ____ +past S_{nonfinite}

5yrs

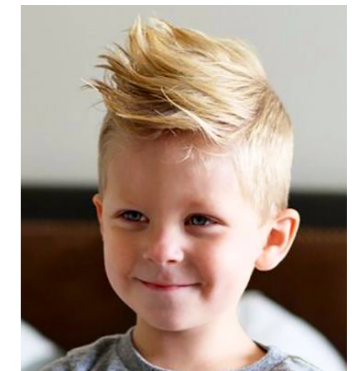

+surfmorph

UTAH rUTAH
+expmap



The ice seemed to melt.

It suggests there are different timelines for
- ignoring vs. heeding surface morphology on verbs ...

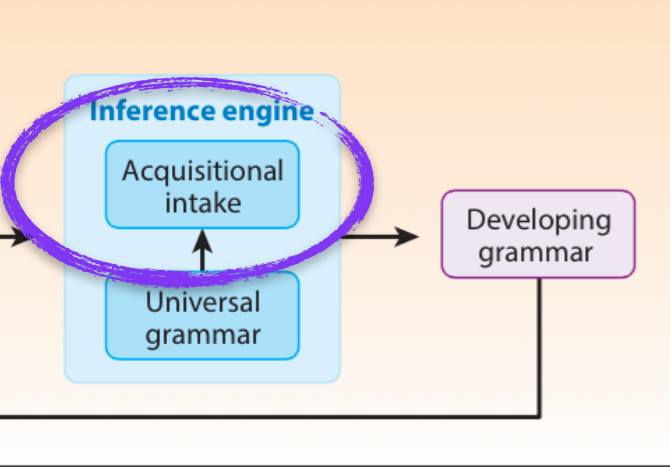

3yrs



-surfmorph

rUTAH

Agent > Experiencer >
 Theme > Patient >
 (Source, Goal, Instrument)



4yrs



+surfmorph

UTAH

-expmap

Agent > Experiencer >
 Theme > Patient >
 (Source, Goal, Instrument)

5yrs

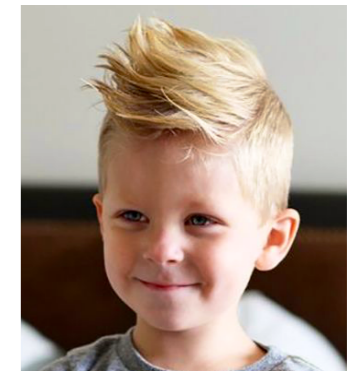

+surfmorph

UTAH rUTAH

+expmap

It suggests there are different timelines for

- ignoring vs. heeding surface morphology on verbs
- a more fixed vs. more relative intermediate thematic representation...

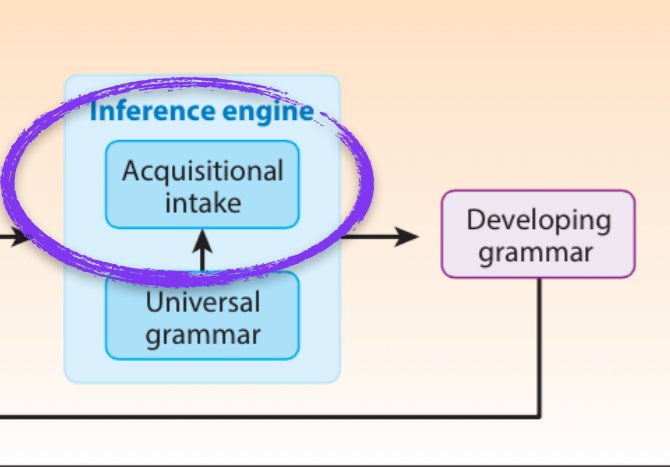

3yrs



-surfmorph
rUTAH

4yrs



+surfmorph
UTAH
-expmap

5yrs

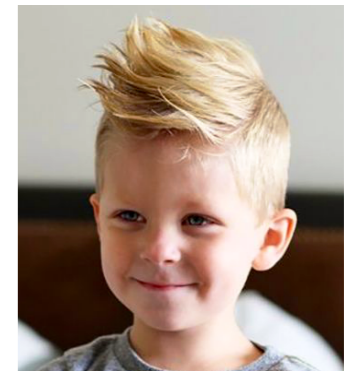

+surfmorph
UTAH rUTAH
+expmap

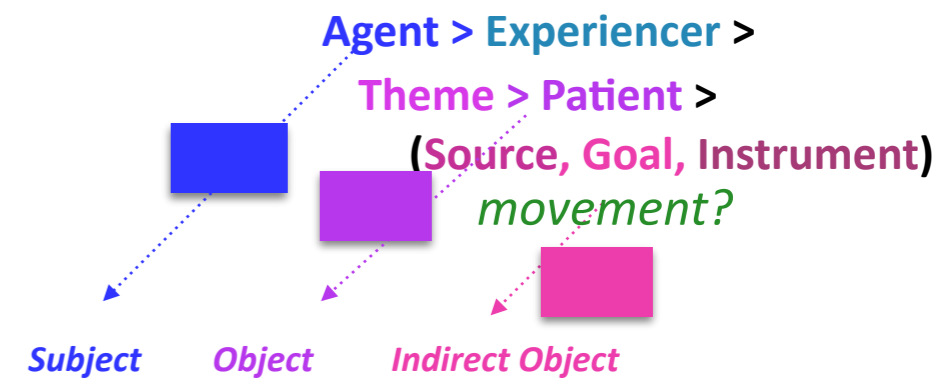

It suggests there are different timelines for

- ignoring vs. heeding surface morphology on verbs
- a more fixed vs. more relative intermediate thematic representation...
- **not expecting vs. expecting a mapping between that intermediate thematic representation and syntactic positions**

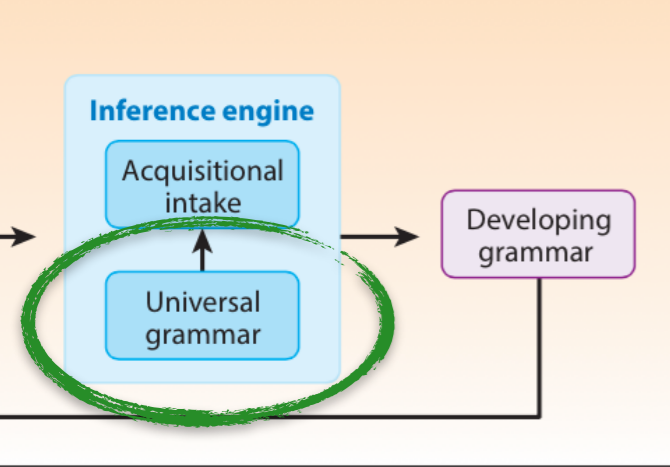

3yrs



-surfmorph
rUTAH

4yrs



+surfmorph
UTAH
-expmap

5yrs

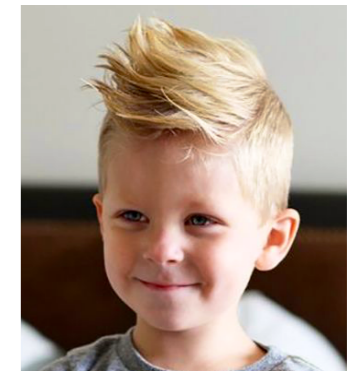

+surfmorph
UTAH rUTAH
+expmap

What does this mean for linguistic theory?



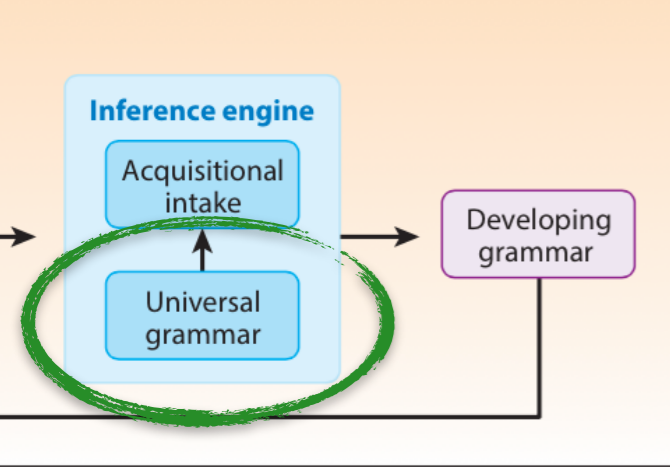

3yrs



-surfmorph
rUTAH

4yrs



+surfmorph
UTAH
-expmap

5yrs



+surfmorph
UTAH rUTAH
+expmap

What doesn't need to be built in

An expectation for how to map between intermediate thematic representations and grammatical positions.

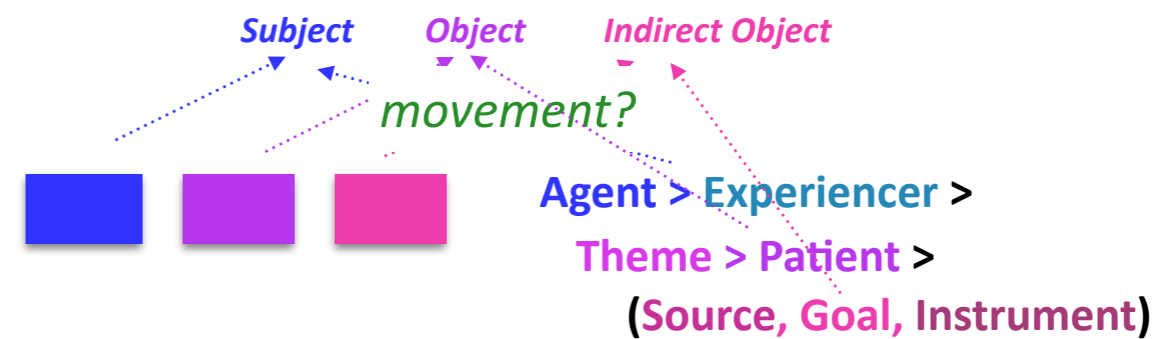
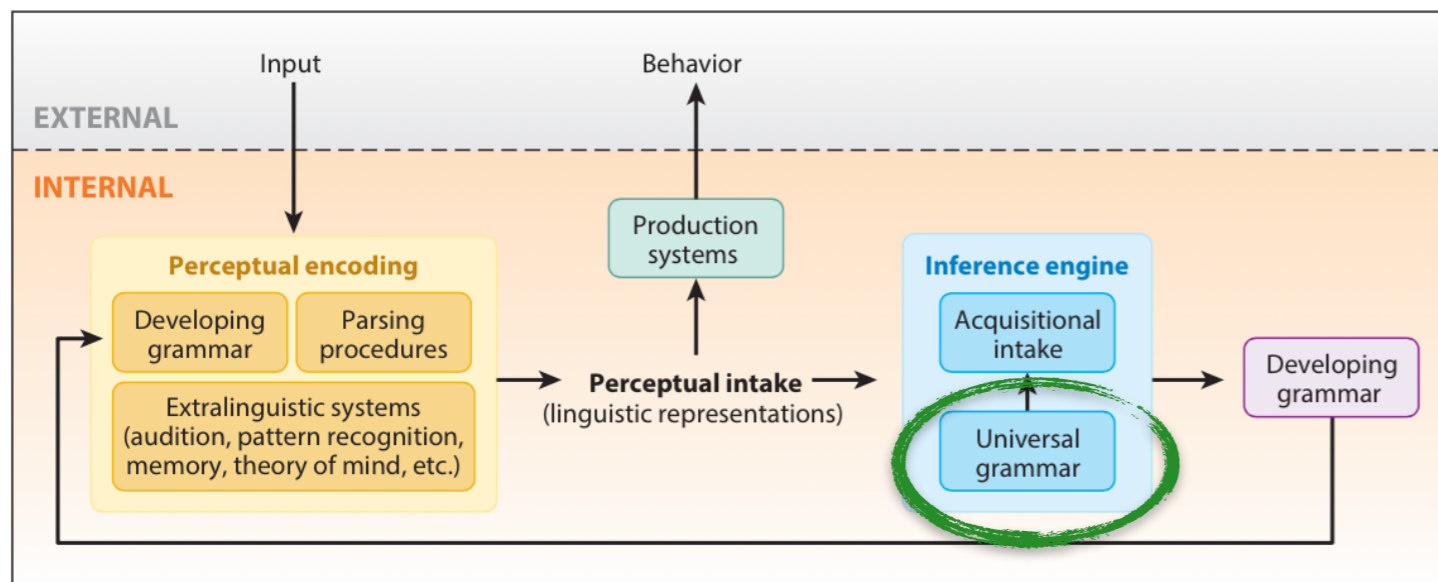

What we saw today

Verb classes



done-to

The ice melted.

The penguin climbed.

doer



Computational modeling

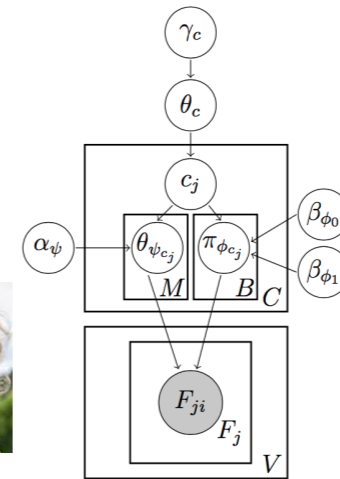
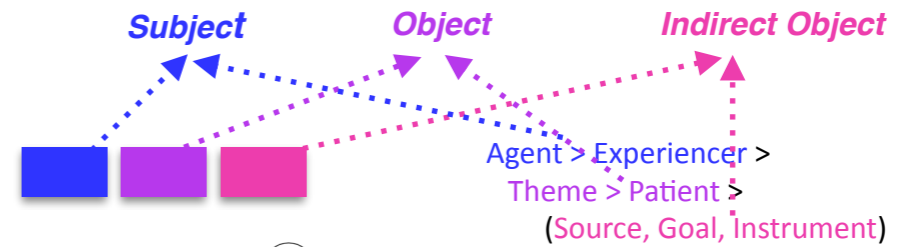
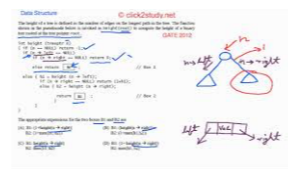

Results & implications

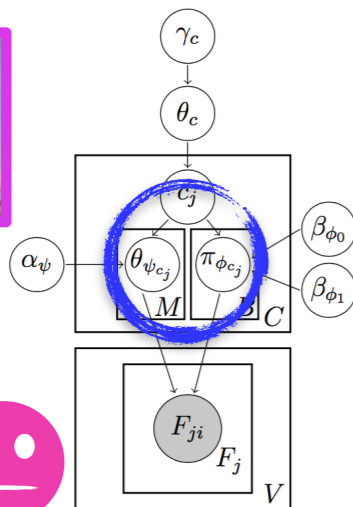

What we saw today

Verb classes: An example of complex linguistic knowledge that children develop, involving several theoretical options for the representations they may be using and how they're integrating conceptual and syntactic information.



done-to

The ice melted.

The penguin climbed.

doer



Computational modeling

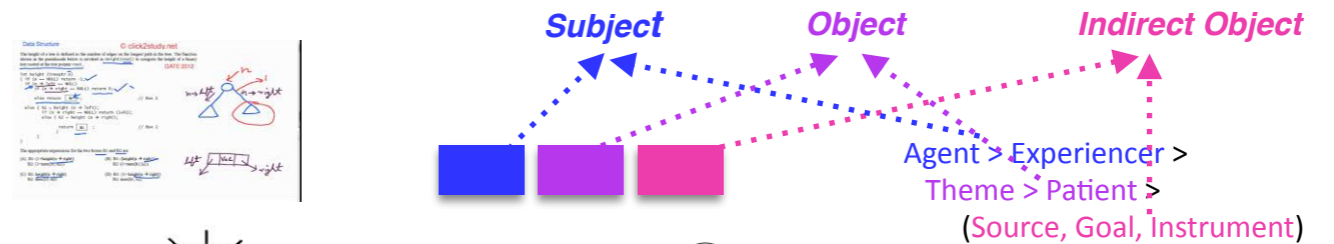

Results & implications

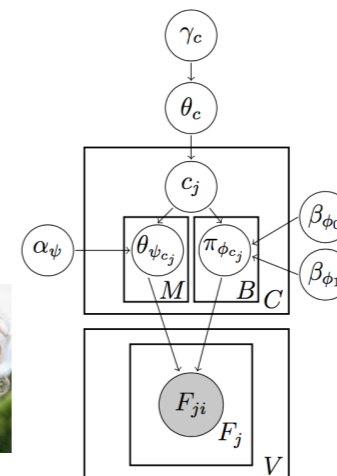
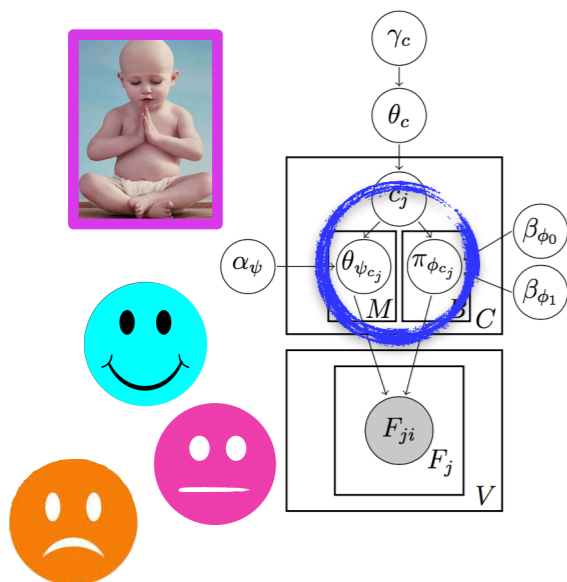

What we saw today

Verb classes: complex linguistic knowledge involving several theoretical options for representations

Computational modeling: A way to explicitly test these theories by implementing them concretely in an empirically grounded model of the acquisition process.

done-to

The ice melted.
The penguin climbed.

doer

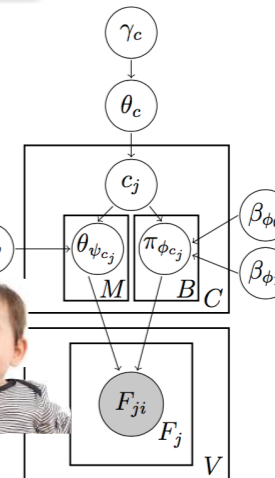
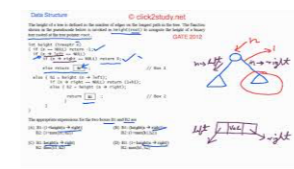
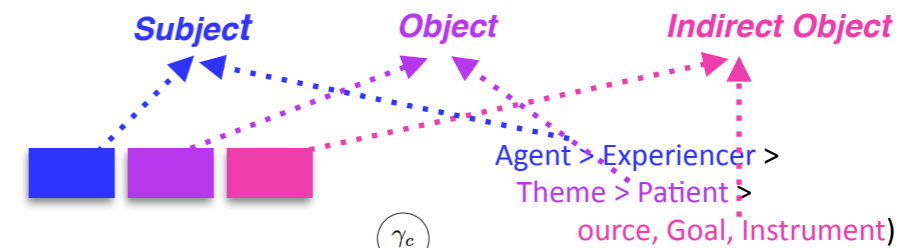

Results & implications

The collage includes a baby in a purple frame, a laughing child in a green jacket, a smiling child in a blue shirt, and a young boy with blonde hair. Below the images is a model diagram similar to the one in the previous slide, but with a blue circle around the c_j node and a smiley face above it. To the left of the diagram are three smiley faces: a blue one with a wide smile, a pink one with a neutral expression, and an orange one with a frown.

What we saw today

Verb classes: complex linguistic knowledge involving several theoretical options for representations

Computational modeling: explicitly test these theories

done-to

The ice melted.
The penguin climbed.

doer

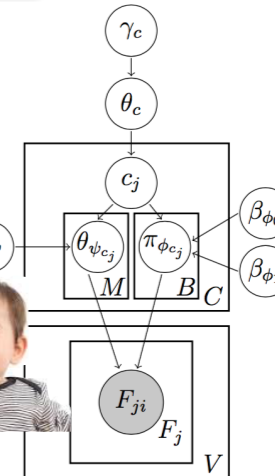
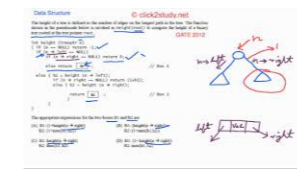
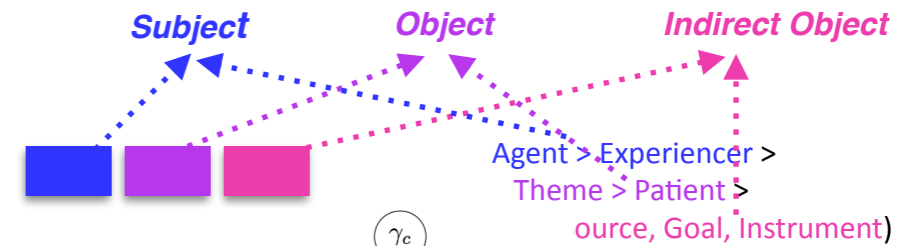

Results & implications:
Articulating the trajectory of representations and learning assumptions children have at different stages of development

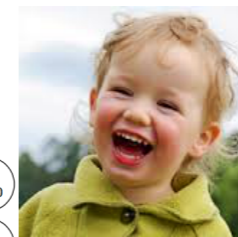
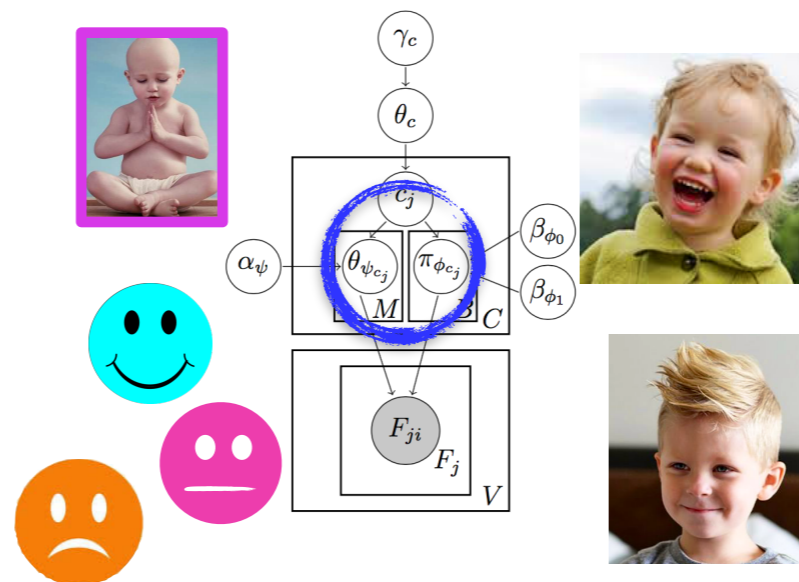

What we saw today

Verb classes: complex linguistic knowledge involving several theoretical options for representations

Computational modeling: explicitly test these theories

done-to

The ice melted.
The penguin climbed.
doer

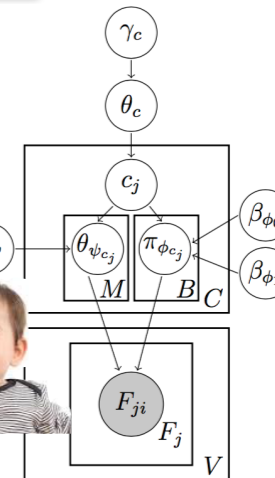
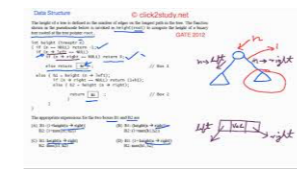
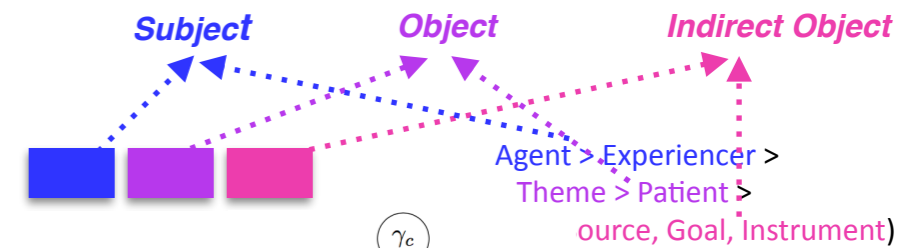

Results & implications:
Articulating the representational trajectory over development

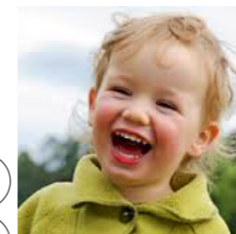
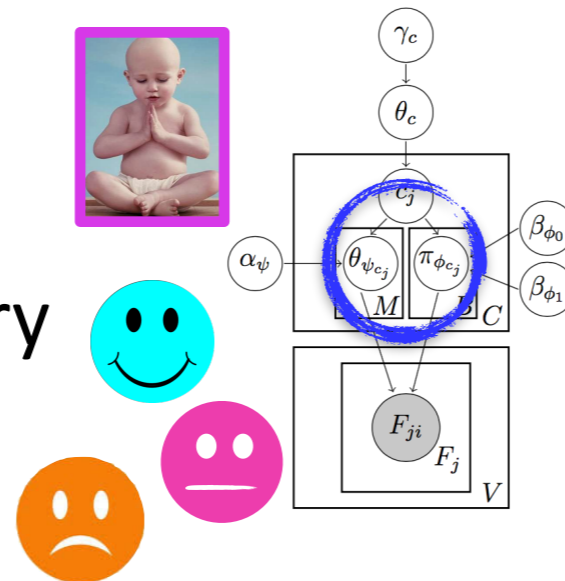

This approach allows us to connect theories of **linguistic representation** and theories of **language acquisition** to understand more about both.

Thank you!

Jon Sprouse



UCI Linguistics 2017
SynLinks workshop 2016
McGill Linguistics 2016



done-to

The ice melted.
The penguin climbed.

doer

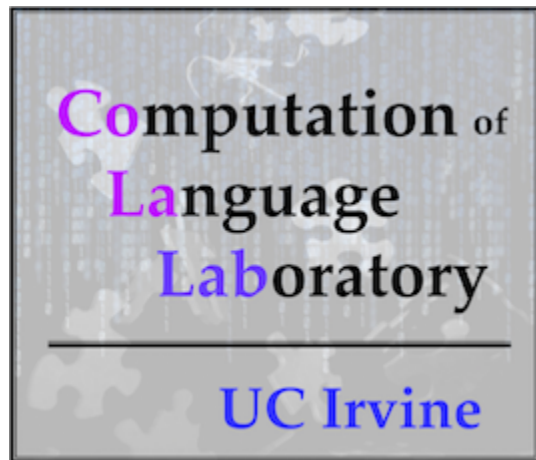
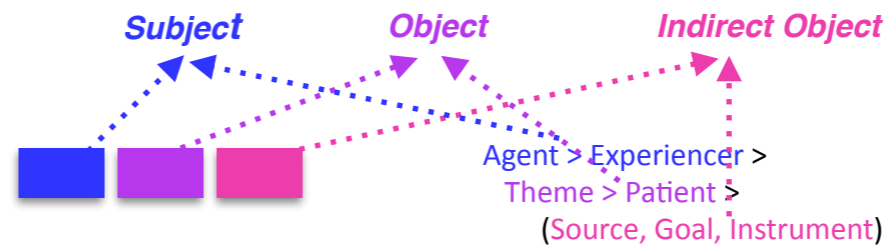
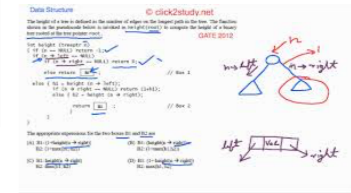
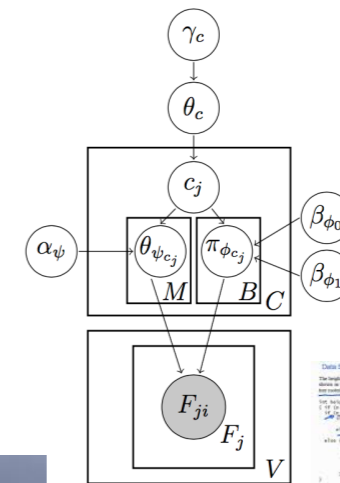

Lisa S. Pearl
Associate Professor
Department of Linguistics
Department of Cognitive Sciences
SSPB 2219, SBSG 2314
University of California, Irvine
lpearl@uci.edu

This work was supported in part
by NSF grant BCS-1347028.



Special thanks to Abbie Thornton, Alandi Bates, Emily Yang,
and BreAnna Silva for CHILDES Treebank corpus annotation.



Language acquisition = Information processing task

Given the available input ...



The penguin
tried to climb.



The ice seemed
to melt.



Language acquisition = Information processing task

Given the available input, information processing done by human minds...



The penguin
tried to climb.



The ice seemed
to melt.



Language acquisition = Information processing task

Given the available input, information processing done by human minds to build a **system of linguistic knowledge** ...



The penguin tried to climb.



The ice seemed to melt.

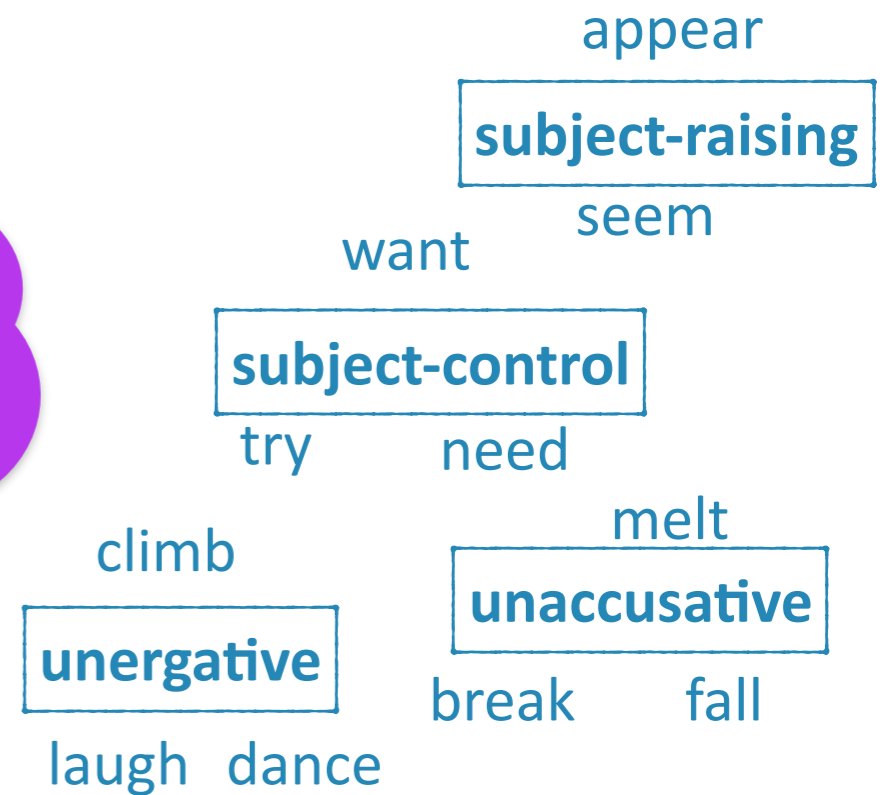

Language acquisition = Information processing task

Given the available input, information processing done by human minds to build a system of linguistic knowledge **whose output we observe**



appear
subject-raising

seem
want

subject-control

try need

climb

unergative

laugh dance

melt
unaccusative

break fall



The penguin tried to climb.



The ice seemed to melt.



The penguin wanted to dance.

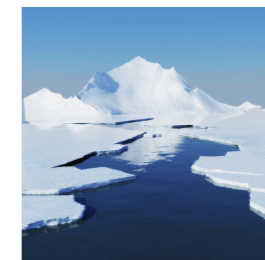

It appeared that the ice broke.

Language acquisition = Information processing task

To understand how children solve the acquisition task, we need to make explicit the relevant components of the task.

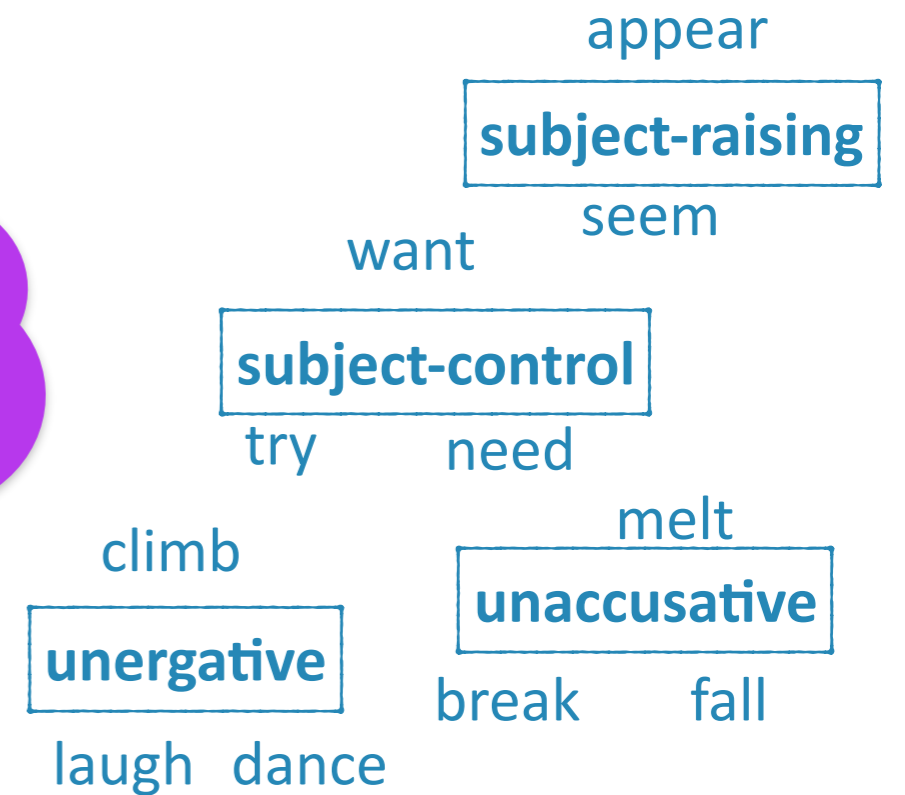
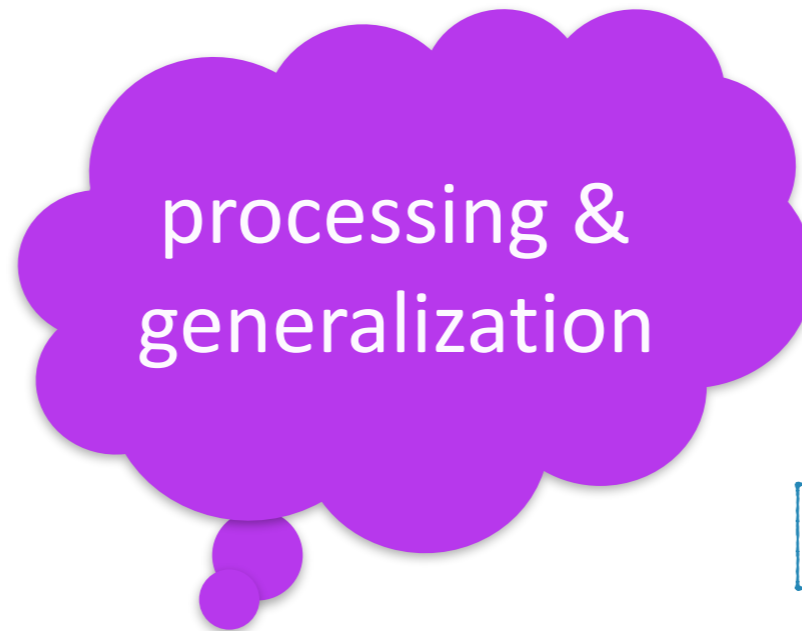

The penguin tried to climb.



The ice seemed to melt.



The penguin wanted to dance.



It appeared that the ice broke.

Thematic roles & how to use them

One idea about how children could use thematic role information: (r)UTAH.

The (relativized) Uniformity of Theta Assignment Hypothesis

UG knowledge

UTAH: Baker 1988, Baker 1997, Dowty 1991, Fillmore 1968, Grimshaw 1990, Jackendoff 1987, Perlmutter & Postal 1984, Speas 1990
Each thematic role maps to a specific syntactic position (grammatical role).

control



She **tried** to **melt** the ice.

doer
doer

done-to

*It **tried** that she **melted** the ice.

doer

done-to



The penguin **seemed** to **climb** the hill.

doer

done-to

It **seemed** that the penguin **climbed** the hill.

doer

done-to

raising

Thematic roles & how to use them

One idea about how children could use thematic role information: (r)UTAH.

The (relativized) Uniformity of Theta Assignment Hypothesis

UG knowledge

UTAH: Baker 1988, Baker 1997, Dowty 1991, Fillmore 1968, Grimshaw 1990, Jackendoff 1987, Perlmutter & Postal 1984, Speas 1990
Each thematic role maps to a specific syntactic position (grammatical role).

Agent-like = grammatical subject

- Agent
- Causer
- Experiencer
- Possessor

(“internal cause” = Rappaport-Hovav 1995)



control

She *tried* to melt the ice.
doer *done-to*

*It *tried* that she *melted* the ice.
doer *done-to*



The penguin *seemed* to climb the hill.
doer *done-to*

It *seemed* that the penguin *climbed* the hill.
doer *done-to*

raising

Thematic roles & how to use them

One idea about how children could use thematic role information: (r)UTAH.

The (relativized) Uniformity of Theta Assignment Hypothesis

UG knowledge

UTAH: Baker 1988, Baker 1997, Dowty 1991, Fillmore 1968, Grimshaw 1990, Jackendoff 1987, Perlmutter & Postal 1984, Speas 1990
Each thematic role maps to a specific syntactic position (grammatical role).

Agent-like = grammatical subject

- Agent
- Causer
- Experiencer (*Baker: only when subject)
- Possessor

("internal cause" = Rappaport-Hovav 1995)



control

She *tried* to melt the ice.
doer *done-to*

*It *tried* that she *melted* the ice.
doer *done-to*



The penguin *seemed* to climb the hill.
doer *done-to*

It *seemed* that the penguin *climbed* the hill.
doer *done-to*

raising

She *fears* spiders.
Experiencer



Spiders *frighten* her.
Experiencer

Thematic roles & how to use them

One idea about how children could use thematic role information: (r)UTAH.

The (relativized) Uniformity of Theta Assignment Hypothesis

UG knowledge

UTAH: Baker 1988, Baker 1997, Dowty 1991, Fillmore 1968, Grimshaw 1990, Jackendoff 1987, Perlmutter & Postal 1984, Speas 1990
Each thematic role maps to a specific syntactic position (grammatical role).

Agent-like = grammatical subject

Patient-like = grammatical object

Patient

Theme

Experiencer

Subject Matter

(“external cause”)



control

She tried to melt the ice.

doer
doer

done-to

*It tried that she melted the ice

doer

done-to



The penguin seemed to climb the hill.

doer

done-to

It seemed that the penguin climbed the hill.

doer

done-to

raising

Thematic roles & how to use them

One idea about how children could use thematic role information: (r)UTAH.

The (relativized) **U**niformity of **T**heta **A**ssignment **H**ypothesis

UG knowledge

UTAH: Baker 1988, Baker 1997, Dowty 1991, Fillmore 1968, Grimshaw 1990, Jackendoff 1987, Perlmutter & Postal 1984, Speas 1990

Each thematic role maps to a specific syntactic position (grammatical role).

Agent-like = grammatical subject

Patient-like = grammatical object

Patient

Theme

Experiencer (*Baker: only when not subject)

Subject Matter

("external cause")



control

She tried to melt the ice.

doer
doer

done-to

*It tried that she melted the ice

doer

done-to

She fears spiders.

Experiencer

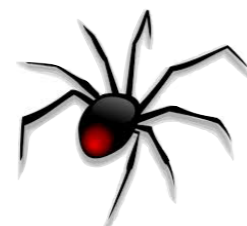

Spiders frighten her.

Experiencer



The penguin seemed to climb the hill.

doer

done-to

It seemed that the penguin climbed the hill.

doer

done-to

raising

Thematic roles & how to use them

One idea about how children could use thematic role information: (r)UTAH.

The (relativized) Uniformity of Theta Assignment Hypothesis

UG knowledge

UTAH: Baker 1988, Baker 1997, Dowty 1991, Fillmore 1968, Grimshaw 1990, Jackendoff 1987, Perlmutter & Postal 1984, Speas 1990
Each thematic role maps to a specific syntactic position (grammatical role).

- Agent-like = grammatical subject
- Patient-like = grammatical object
- Goal-like = grammatical indirect object



- Location
- Source
- Goal
- Benefactor
- Instrument



control

She *tried* to *melt* the ice with a blow dryer.
doer *doer* *done-to* *done-with*

*It *tried* that she *melted* the ice with a blow dryer.
doer *done-to* *done-with*

The penguin *seemed* to *climb* the hill.
doer *done-to*

It *seemed* that the penguin *climbed* the hill.
doer *done-to*

raising

Thematic roles & how to use them



Syntax

She melted the ice with a blow dryer.

Subject

Object

Indirect Object

Mapping to Syntax

UG knowledge

The **U**niformity of **T**heta **A**ssignment **H**ypothesis:

Baker 1988, Baker 1997, Dowty 1991, Fillmore 1968, Grimshaw 1990, Jackendoff 1987, Perlmutter & Postal 1984, Speas 1990

UTAH

Intermediate representations

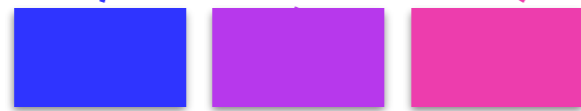

Thematic roles map to one of three categories.

thematic-roles

(likely derived from lower level conceptual info) =
Agent, Experiencer, Patient, Theme, Goal, Source, Instrument...

Thematic roles & how to use them

One idea about how children could use thematic role information: (r)UTAH.

The (r)elativized U niformity of T heta A ssignment H ypothesis

UG knowledge

rUTAH: Larson 1988, Larson 1990

Thematic roles are ordered relative to each other, with the highest thematic role mapping to the highest grammatical role (subject > object > indirect object).

control



She **tried** to **melt** the ice with a blow dryer.

doer
doer

done-to

done-with

*It **tried** that she **melted** the ice with a blow dryer.

doer

done-to

done-with



The penguin **seemed** to **climb** the hill.

doer

done-to

It **seemed** that the penguin **climbed** the hill.

doer

done-to

raising

Thematic roles & how to use them

One idea about how children could use thematic role information: (r)UTAH.

The (r)elativized U niformity of T heta A ssignment H ypothesis

UG knowledge

rUTAH: Larson 1988, Larson 1990

Thematic roles are ordered relative to each other, with the highest thematic role mapping to the highest grammatical role (subject > object > indirect object).

Basic intuition:

doer (Agent-like) >

done-to (Patient-like) >

done-for/with (Goal-like)



control

She **tried** to **melt** the ice with a blow dryer.

doer
doer

done-to

done-with

*It **tried** that she **melted** the ice with a blow dryer.

doer

done-to

done-with



The penguin **seemed** to **climb** the hill.

doer

done-to

It **seemed** that the penguin **climbed** the hill.

doer

done-to

raising

Thematic roles & how to use them

One idea about how children could use thematic role information: (r)UTAH.

The (r)elativized U niformity of T heta A ssignment H ypothesis

UG knowledge

rUTAH: Larson 1988, Larson 1990

Thematic roles are ordered relative to each other, with the highest thematic role mapping to the highest grammatical role (subject > object > indirect object).

Basic intuition:

doer (Agent-like) >

done-to (Patient-like) >

done-for/with (Goal-like)



An example implementation:

Agent > Causer > Experiencer > Possessor >

Subject Matter > Causee > Theme > Patient >

(Location, Source, Goal, Benefactor, Instrument)



control

She **tried** to **melt** the ice with a blow dryer.

doer
doer

done-to

done-with

*It **tried** that she **melted** the ice with a blow dryer.

doer

done-to

done-with

The penguin **seemed** to **climb** the hill.

doer

done-to

It **seemed** that the penguin **climbed** the hill.

doer

done-to

raising

Thematic roles & how to use them

One idea about how children could use thematic role information: (r)UTAH.

The (r)elativized U niformity of T heta A ssignment H ypothesis

UG knowledge

rUTAH: Larson 1988, Larson 1990

Thematic roles are ordered relative to each other, with the highest thematic role mapping to the highest grammatical role (subject > object > indirect object).

Basic intuition:

doer (Agent-like) >

done-to (Patient-like) >

done-for/with (Goal-like)



An example implementation:

Agent > Causer > Experiencer > Possessor >

Subject Matter > Causee > Theme > Patient >

(Location, Source, Goal, Benefactor, Instrument)

Note: You don't need to have every role relatively ranked. If some are unranked with respect to each other, the order in which they get mapped to grammatical positions doesn't matter.



control

She **tried** to **melt** the ice with a blow dryer.

doer
doer

done-to

done-with

*It **tried** that she **melted** the ice with a blow dryer.

doer

done-to

done-with

The penguin **seemed** to **climb** the hill.

doer

done-to

It **seemed** that the penguin **climbed** the hill.

doer

done-to

raising

Thematic roles & how to use them

One idea about how children could use thematic role information: (r)UTAH.

The (relativized) Uniformity of Theta Assignment Hypothesis

UG knowledge

rUTAH: Larson 1988, Larson 1990

Thematic roles are ordered relative to each other, with the highest thematic role mapping to the highest grammatical role (subject > object > indirect object).

Basic intuition:

doer (Agent-like) >

done-to (Patient-like) >

done-for/with (Goal-like)

An example implementation:

Agent > Causer > Experiencer > Possessor >

Subject Matter > Causee > Theme > Patient >

(Location, Source, Goal, Benefactor, Instrument)

This relative ranking can help deal with certain situations, like those involving Experiencers.

She fears spiders.
Experiencer Subject Matter

Experiencer > Subject Matter

Subject Object



Spiders frighten her.

Causer Experiencer

Causer > Experiencer

Subject Object

Potential learning strategies

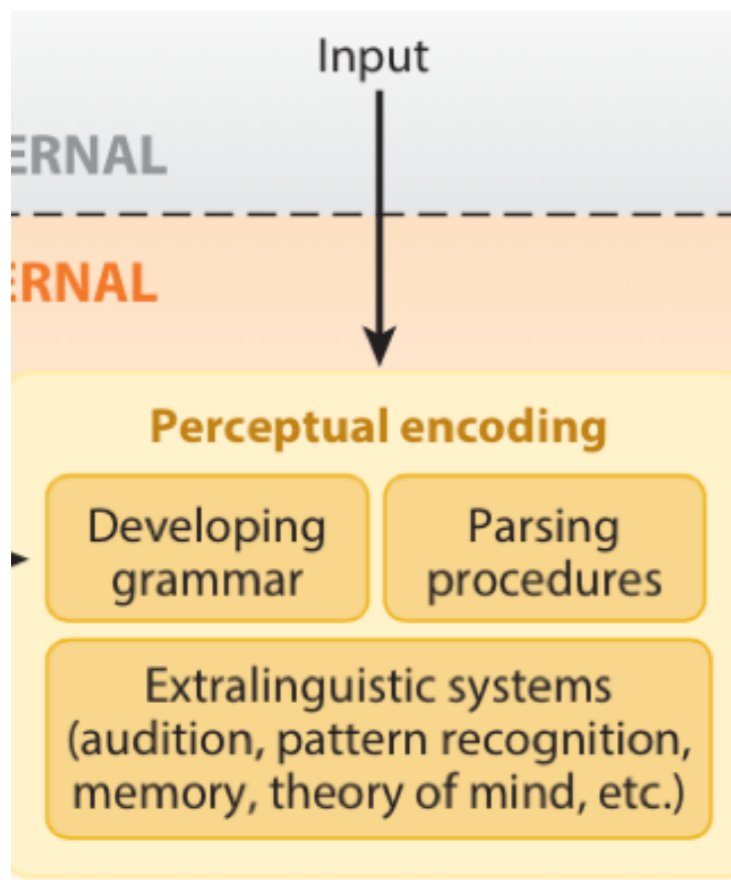

Animacy

+animate
The penguin tried
to climb.



-animate
The ice seemed
to melt.



Syntactic frame

Choice 1

NP	___	S _{nonfinite}	-surfmorph
NP	___+past	S _{nonfinite}	+surfmorph

Thematic roles and how to use them

Choice 2

■ ■ ■ UTAH
 Agent > Experiencer > rUTAH
 Theme > Patient >
 (Source, Goal, Instrument)

Choice 3

<i>Subject</i>	<i>Object</i>	<i>Indirect Object</i>	-expmap
<i>Subject</i>	<i>Object</i>	<i>Indirect Object</i>	+expmap

↗ ↗ ↗
movement?

3 binary choices = 8 strategies

All strategies require learner's initial state to be sufficient to extract this information from the input

Potential acquisitional intakes

3 binary choices = 8 strategies

Each strategy has a different impact on the acquisitional intake

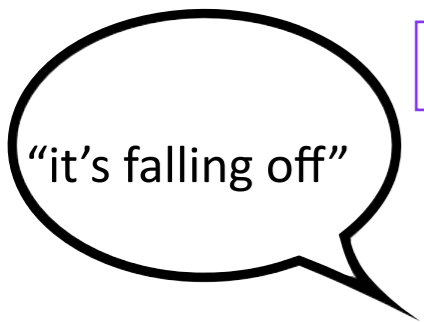
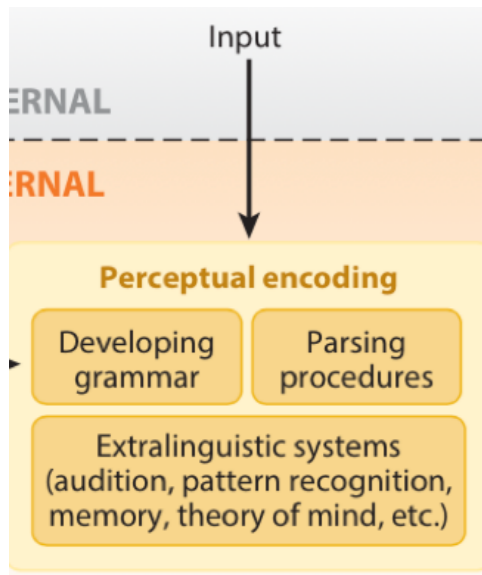

Input



Animacy

Syntactic frame

-surfmorph +surfmorph

Thematic roles and how to use them

UTAH



rUTAH

Agent > Experiencer >
Theme > Patient >
(Source, Goal, Instrument)

-expmap

Subject Object Indirect Object

+expmap

Subject Object Indirect Object

↑ ↑ ↑
movement?

(from Brown-Eve corpus in CHILDES Treebank)

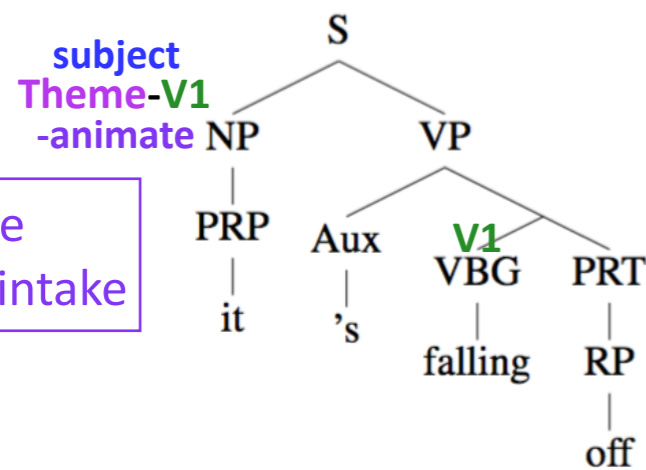
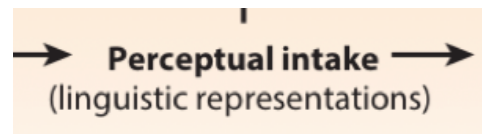

Possible perceptual intake

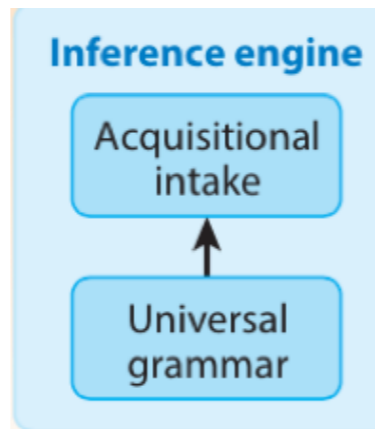

Potential acquisitional intakes

3 binary choices = 8 strategies

Each strategy has a different impact on the acquisitional intake



Input
"it's falling off"

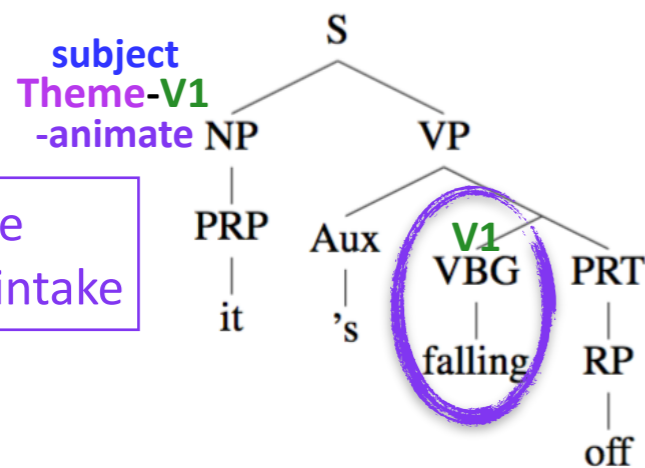

Possible perceptual intake

Animacy

Syntactic frame

-surfmorph +surfmorph

Thematic roles and how to use them

UTAH



rUTAH

Agent > Experiencer >
Theme > Patient >
(Source, Goal, Instrument)

-expmap

Subject Object Indirect Object

+expmap

Subject Object Indirect Object

movement?

FALL

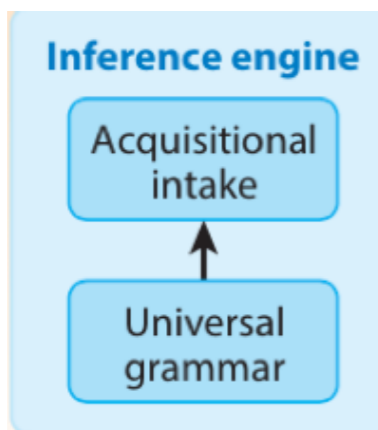

Potential acquisitional intakes

3 binary choices = 8 strategies

Each strategy has a different impact on the acquisitional intake

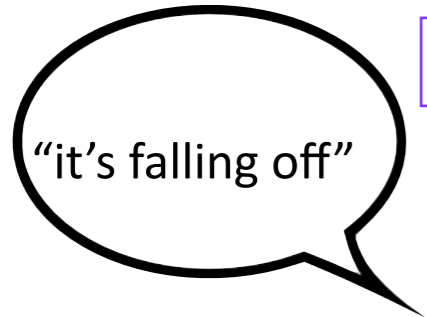

Input



subject
Theme-V1
-animate

Possible
perceptual intake

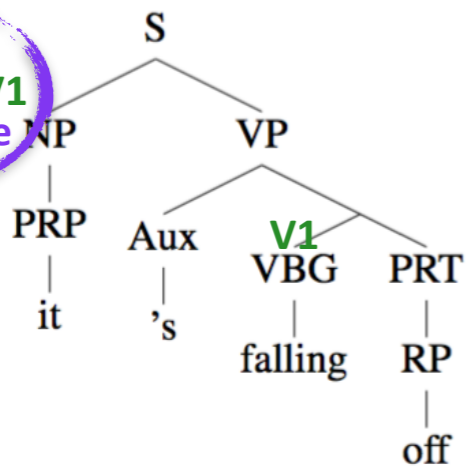

Animacy

Syntactic frame

-surfmorph +surfmorph

Thematic roles and how to use them

UTAH



rUTAH

Agent > Experiencer >
Theme > Patient >
(Source, Goal, Instrument)

-expmap

Subject Object Indirect Object

+expmap

Subject Object Indirect Object

movement?

FALL

-animate subject: 1

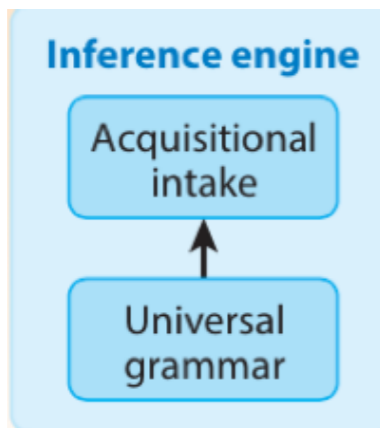

Potential acquisitional intakes

3 binary choices = 8 strategies

Each strategy has a different impact on the acquisitional intake



Input



Animacy

Syntactic frame

+surfmorph

Thematic roles and how to use them

rUTAH

Agent > Experiencer >

Theme > Patient >

(Source, Goal, Instrument)

+expmap

Subject Object Indirect Object

Subject Object Indirect Object

movement?

subject
Theme-V1
-animate

Possible
perceptual intake

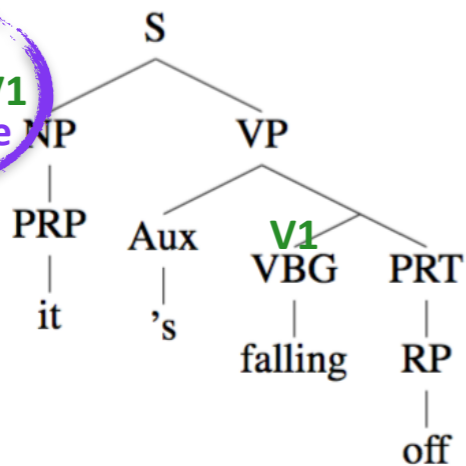

FALL

-animate subject: 1

Done-to as subject: 1

UTAH



-expmap

-surfmorph

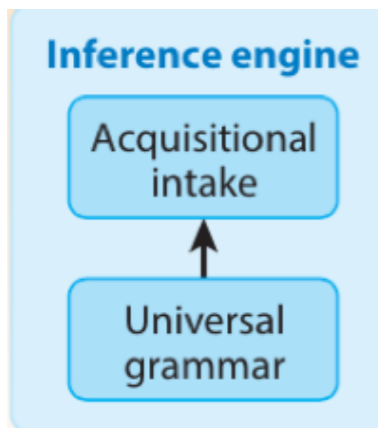

Potential acquisitional intakes

3 binary choices = 8 strategies

Each strategy has a different impact on the acquisitional intake



Input



Animacy

Syntactic frame

+surfmorph

Thematic roles and how to use them

rUTAH

Agent > Experiencer >

Theme > Patient >

(Source, Goal, Instrument)

+expmap

Subject Object Indirect Object

Subject Object Indirect Object

movement?

Possible perceptual intake

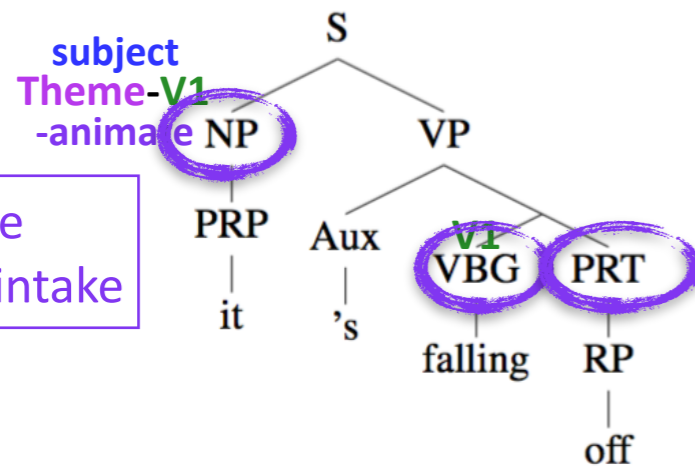

FALL

-animate subject: 1

Done-to as subject: 1

UTAH



-expmap

NP V PRT

-surfmorph

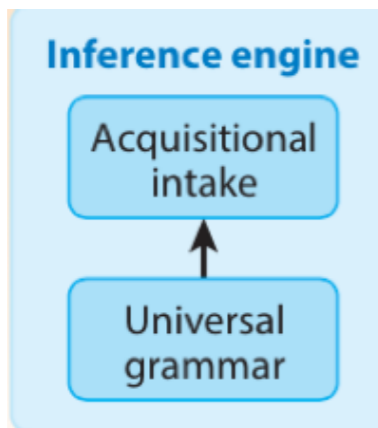

Potential acquisitional intakes

3 binary choices = 8 strategies

Each strategy has a different impact on the acquisitional intake



Input



Animacy

Syntactic frame

-surfmorph

Thematic roles and how to use them

rUTAH

Agent > Experiencer >

Theme > Patient >

(Source, Goal, Instrument)

+expmap

Subject Object Indirect Object

Subject Object Indirect Object

movement?

Possible perceptual intake

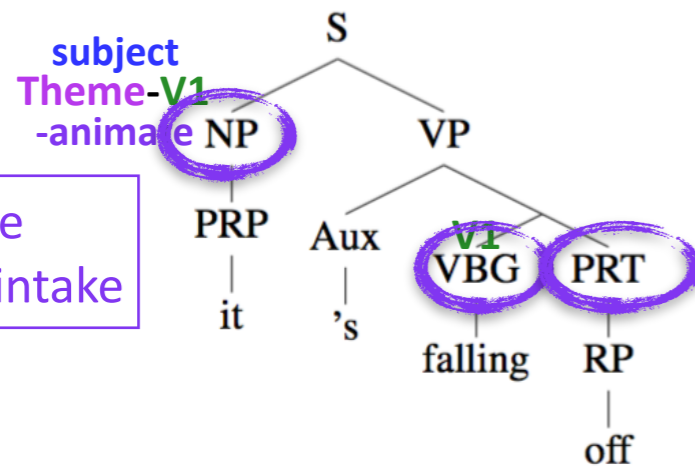

FALL

-animate subject: 1

Done-to as subject: 1

NP V_{+prog} PRT

UTAH



-expmap

+surfmorph

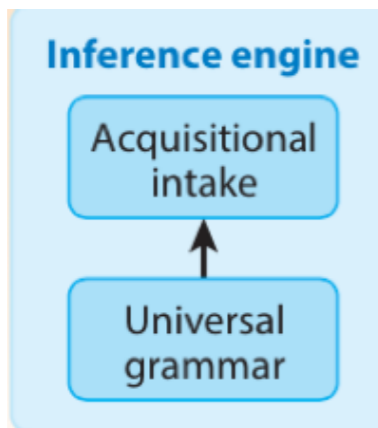

Potential acquisitional intakes

3 binary choices = 8 strategies

Each strategy has a different impact on the acquisitional intake



Input
"it's falling off"

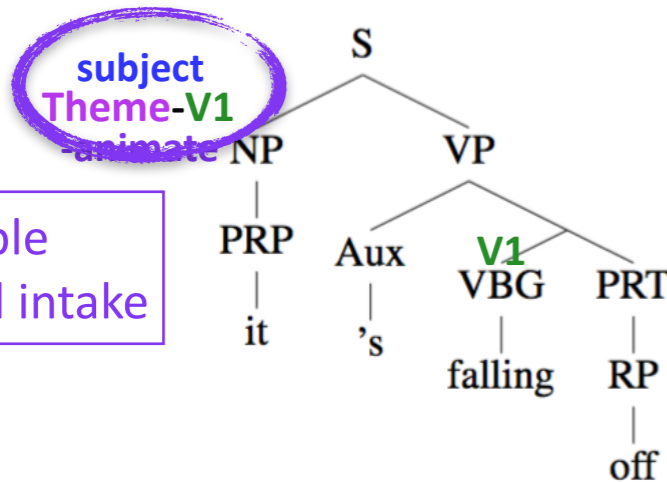

Animacy

Syntactic frame

-surfmorph

Thematic roles and how to use them

rUTAH

Agent > Experiencer >

Theme > Patient >

(Source, Goal, Instrument)

-expmap

Subject Object Indirect Object

Subject Object Indirect Object

movement?

FALL

-animate subject: 1

+movement: 1

NP V_{+prog} PRT

UTAH



+expmap

+surfmorph

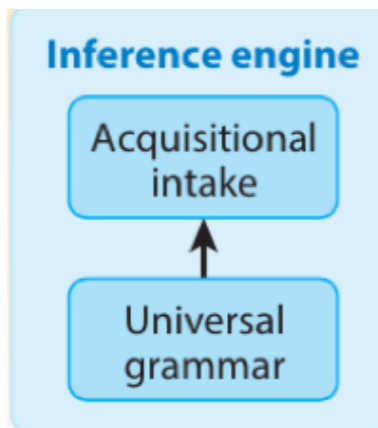

Theme is expected to map to object, not subject. Indicator of movement.

Potential acquisitional intakes

3 binary choices = 8 strategies

Each strategy has a different impact on the acquisitional intake



Input



Animacy

Syntactic frame

-surfmorph

Thematic roles and how to use them

UTAH



-expmap

Subject Object Indirect Object

Subject Object Indirect Object

movement?

Possible perceptual intake

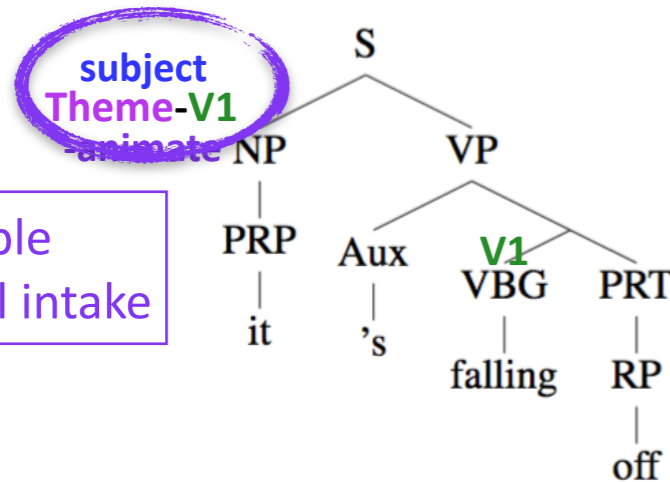

FALL

-animate subject: 1

+movement: 0

NP V_{+prog} PRT

rUTAH

Agent > Experiencer >

Theme > Patient >

(Source, Goal, Instrument)

+expmap

+surfmorph

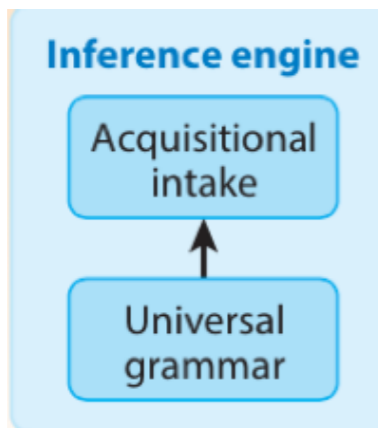

Theme is only role so is default highest. Expected mapping is to highest syntactic position (subject).

Potential acquisitional intakes

3 binary choices = 8 strategies

Each strategy has a different impact on the acquisitional intake



Input



Animacy

Syntactic frame

-surfmorph

Thematic roles and how to use them

UTAH



+expmap

Subject Object Indirect Object

Subject Object Indirect Object

movement?

Possible perceptual intake

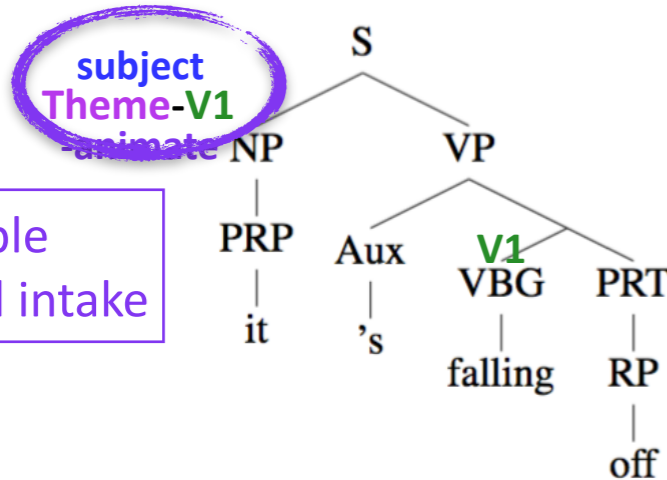

subject
Theme-V1
-animate

FALL

-animate subject: 1

rUTAH
Agent > Experiencer >
Theme > Patient >
(Source, Goal, Instrument)

Highest role as subject: 1

-expmap

NP V_{+prog} PRT

+surfmorph

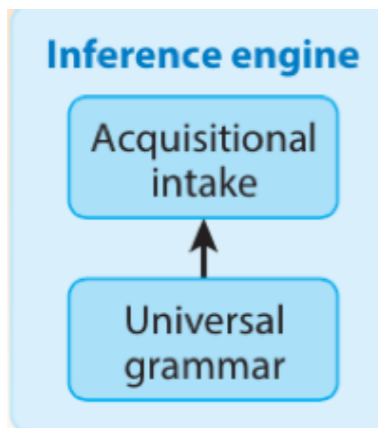

8 modeled learners and their acquisitional intakes



“it’s falling off”

Input

Possible
perceptual intake

FALL

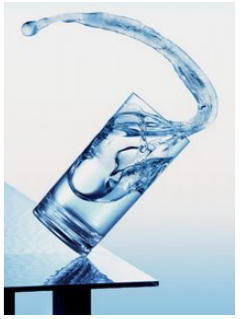
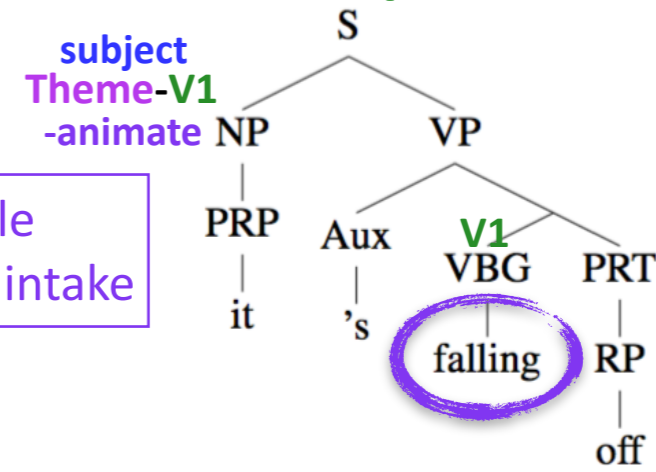

8 modeled learners and their acquisitional intakes



“it’s falling off”

Input

Possible perceptual intake

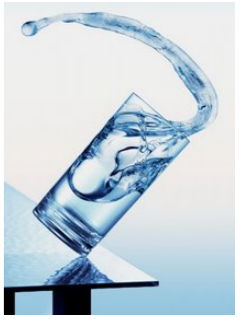
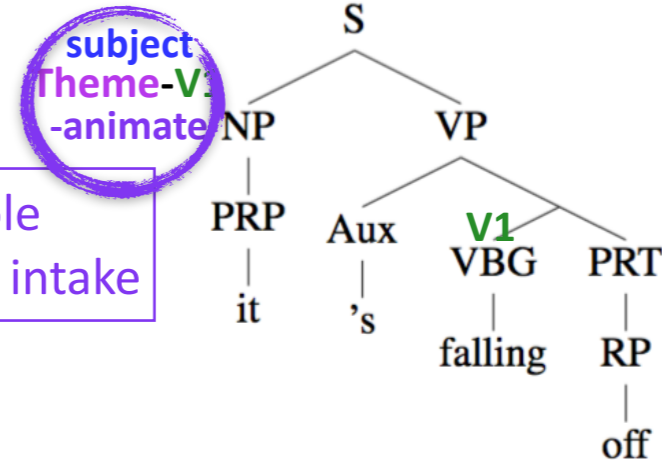

FALL

Animacy

-animate subject: 1

All 8 learners

8 modeled learners and their acquisitional intakes



“it’s falling off”

Input

Possible perceptual intake

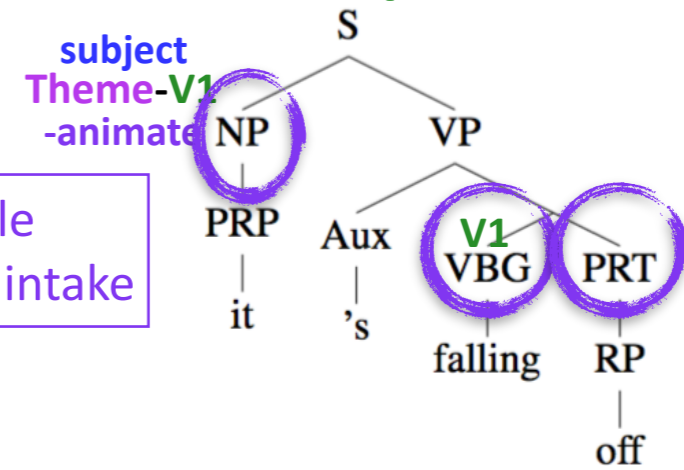

FALL

Animacy

-animate subject: 1

All 8 learners

Syntactic frame

-surfmorph

+surfmorph

4 learners

4 learners

NP V PRT

NP V_{+prog} PRT

8 modeled learners and their acquisitional intakes



“it’s falling off”

Input

Possible perceptual intake

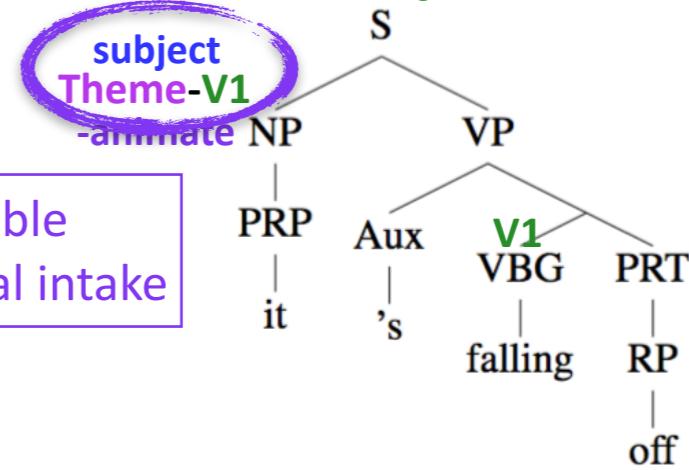

FALL

Animacy

-animate subject: 1

All 8 learners

Syntactic frame

-surfmorph

+surfmorph

4 learners

NP V PRT

4 learners

NP V_{+prog} PRT

Intermediate representation

UTAH

Done-to as subject

2 learners

rUTAH

Highest as subject

2 learners

UTAH

Done-to as subject

2 learners

rUTAH

Highest as subject

2 learners

8 modeled learners and their acquisitional intakes



Input
"it's falling off"

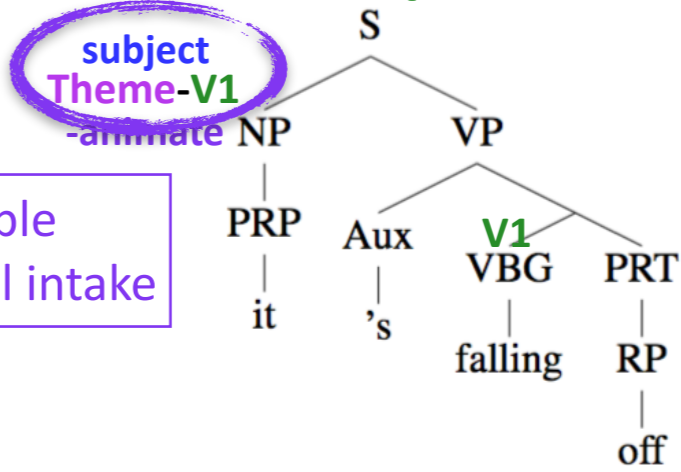

FALL

Animacy -animate subject: 1 All 8 learners

Syntactic frame -surfmorph

+surfmorph

4 learners
NP V PRT

4 learners
NP V_{+prog} PRT

Intermediate representation

UTAH
Done-to as subject

rUTAH
Highest as subject

UTAH
Done-to as subject

rUTAH
Highest as subject

2 learners

2 learners

2 learners

2 learners

Mapping to syntax

+expmap
+mvmt: 1

-expmap
Done-to as subject: 1

+expmap
+mvmt: 0

-expmap
Highest as subject: 1

+expmap
+mvmt: 1

-expmap
Done-to as subject: 1

+expmap
+mvmt: 0

-expmap
Highest as subject: 1

1 learner

1 learner

1 learner

1 learner

1 learner

1 learner

1 learner

1 learner

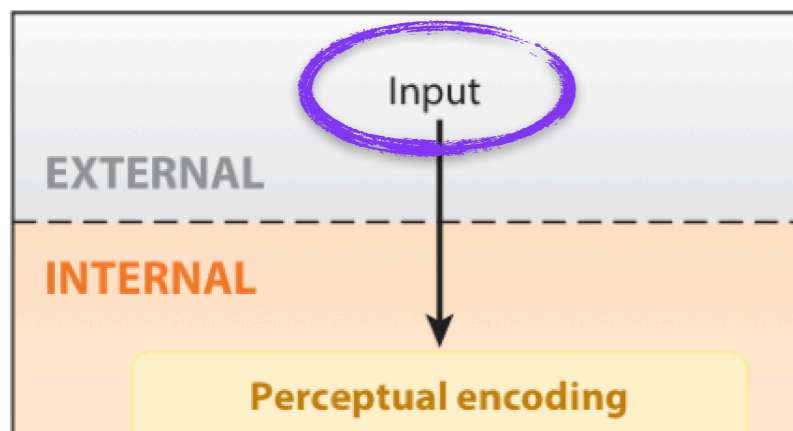

CHILDES Treebank

Goal: Model the developmental trajectory from 3 to 4 to 5 years old



Input

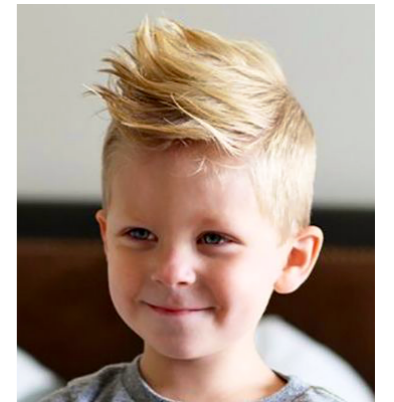

<3 years old

Brown-Eve corpus (Brown 1973) and the Valian corpus (Valian 1991), with syntactic & thematic annotations provided by the CHILDES Treebank (Pearl & Sprouse 2013).

Speech directed at 22 children between 18 and 32 months.

~40,000 utterances (~197,000 word tokens, 555 verbs)



Focus on the 239 verbs occurring 5 or more times.

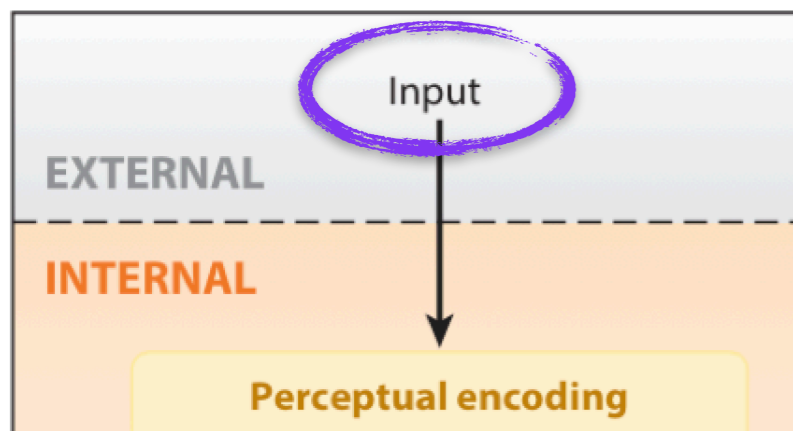

Goal: Model the developmental trajectory from 3 to 4 to 5 years old

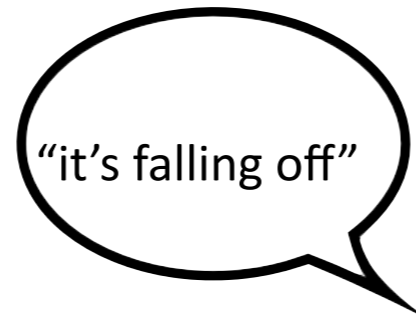

Input

CHILDES Treebank

<3yrs



18 and 32 months
~40,000 utterances
239 verbs

<4 years old

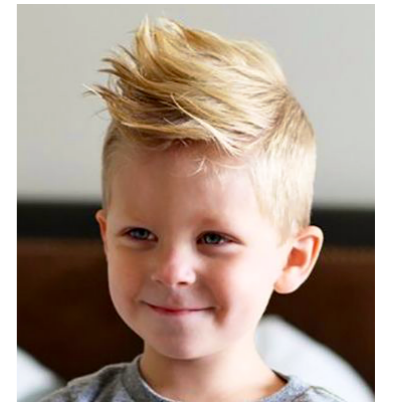

<3yrs + Brown-Adam subsection (Brown 1973), with syntactic & thematic annotations provided by the CHILDES Treebank (Pearl & Sprouse 2013).



Speech directed at 23 children between 18 and 48 months.

~51,000 utterances (~254,000 word tokens, 617 verbs)

Focus on the 267 verbs occurring 5 or more times.

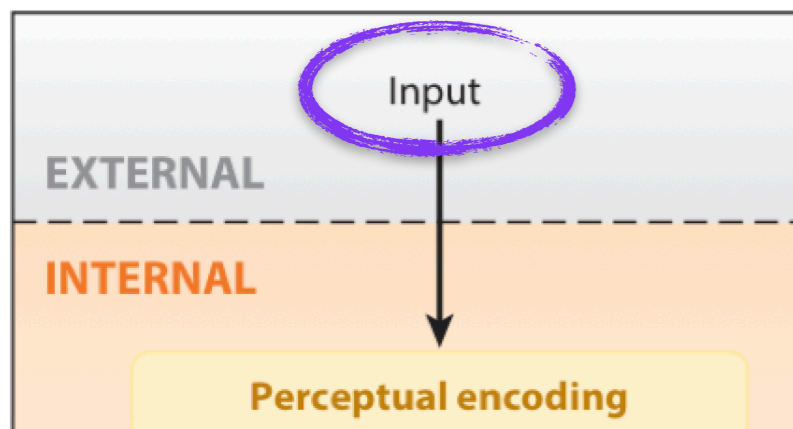

Goal: Model the developmental trajectory from 3 to 4 to 5 years old

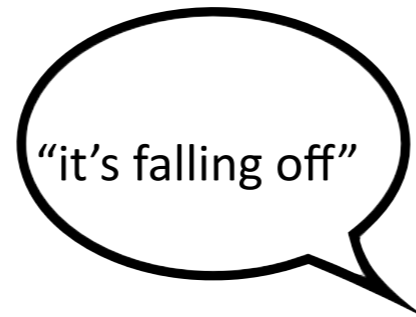

Input

CHILDES Treebank

<3yrs



18 and 32 months
~40,000 utterances
239 verbs

<4yrs



18 and 48 months
~51,000 utterances
267 verbs

<5 years old

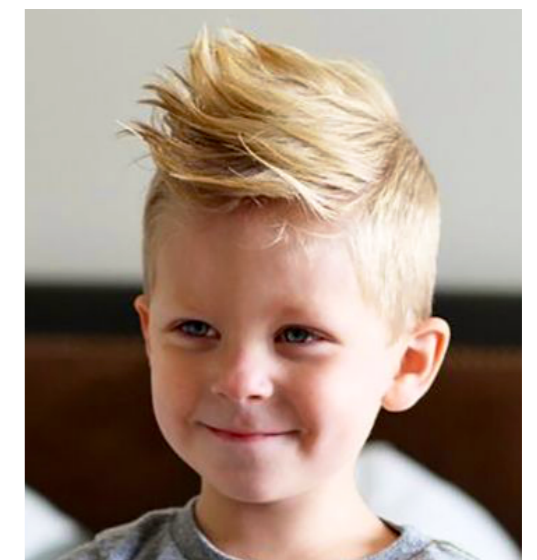

<4yrs + Brown-Adam subsection (Brown 1973), with syntactic & thematic annotations provided by the CHILDES Treebank (Pearl & Sprouse 2013).

Speech directed at 23 children between 18 and 58 months.

~56,500 utterances (~285,000 word tokens, 651 verbs)

Focus on the 284 verbs occurring 5 or more times.

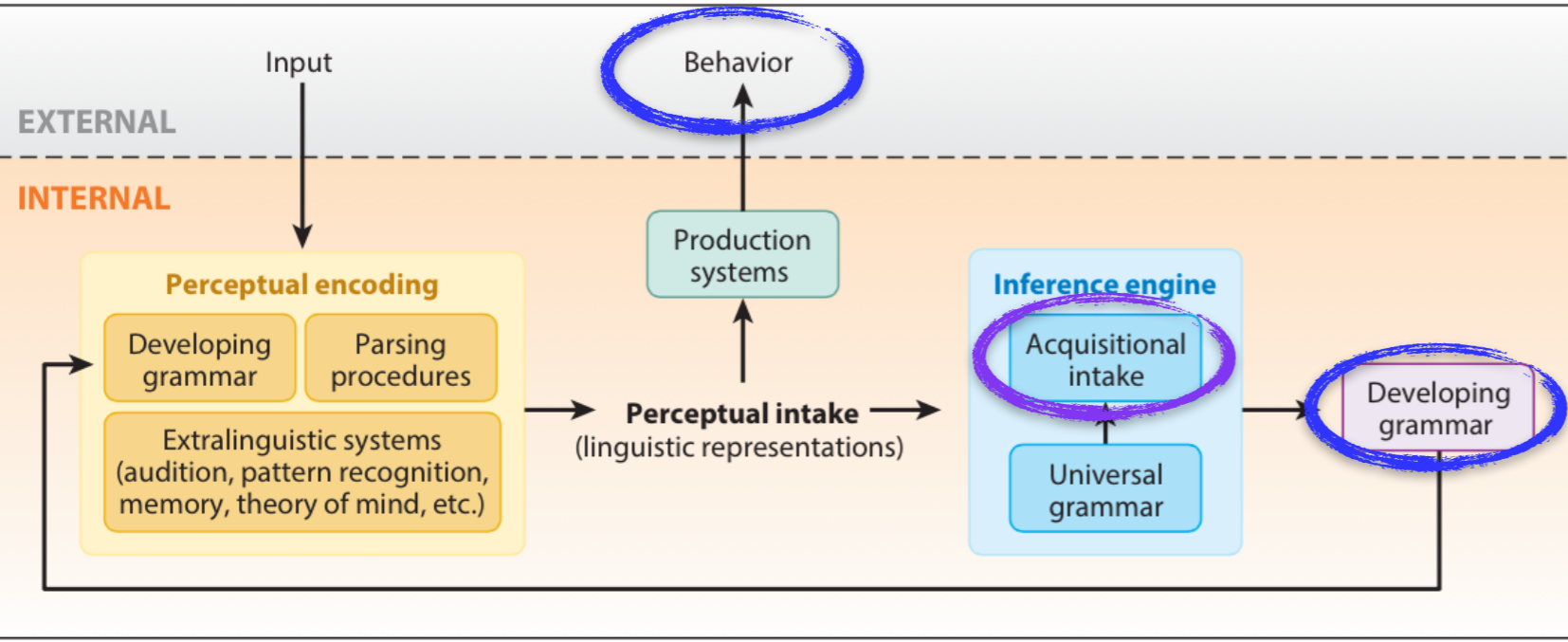

Goal: Model the developmental trajectory from 3 to 4 to 5 years old

<3yrs <4yrs <5yrs



Basic question: Is it possible for the child to use the **acquisitional intake** to achieve the **target knowledge/behavior**?

This is the goal of **learnability** approaches
(**computational-level** of analysis: Marr 1982)

Frank et al. 2009, Goldwater et al. 2009, Pearl et al. 2010, Pearl 2011, Legate & Yang 2012, Dillon et al. 2013, Doyle & Levy 2013, Feldman et al. 2013, Orita et al. 2013

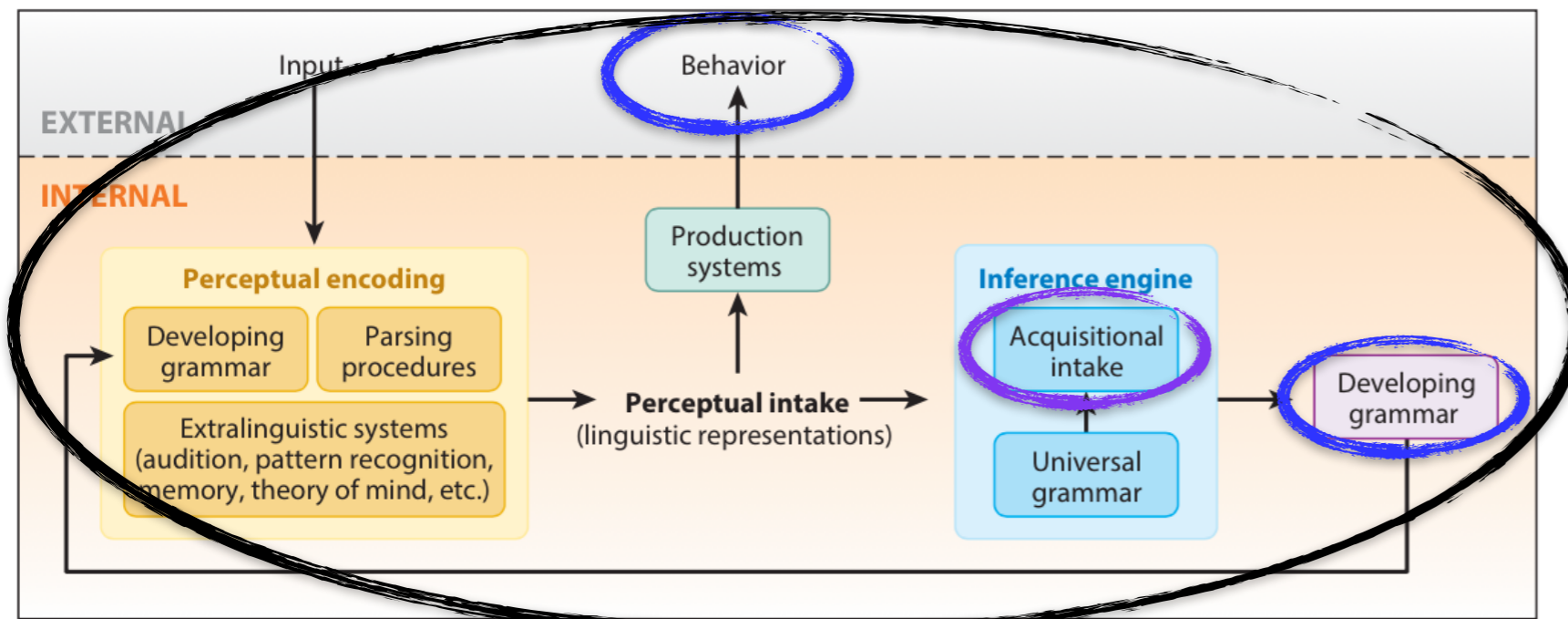

Goal: Model the developmental trajectory from 3 to 4 to 5 years old

<3yrs

<4yrs

<5yrs



Basic question: Is it possible for the child to use the **acquisitional intake** to achieve the **target knowledge/behavior**?

Ideal learner model: Also an excellent first step to see if this is the **right conceptualization** of the acquisition task.



-surfmorph
 +surfmorph
 UTAH
 rUTAH
 -expmap
 +expmap

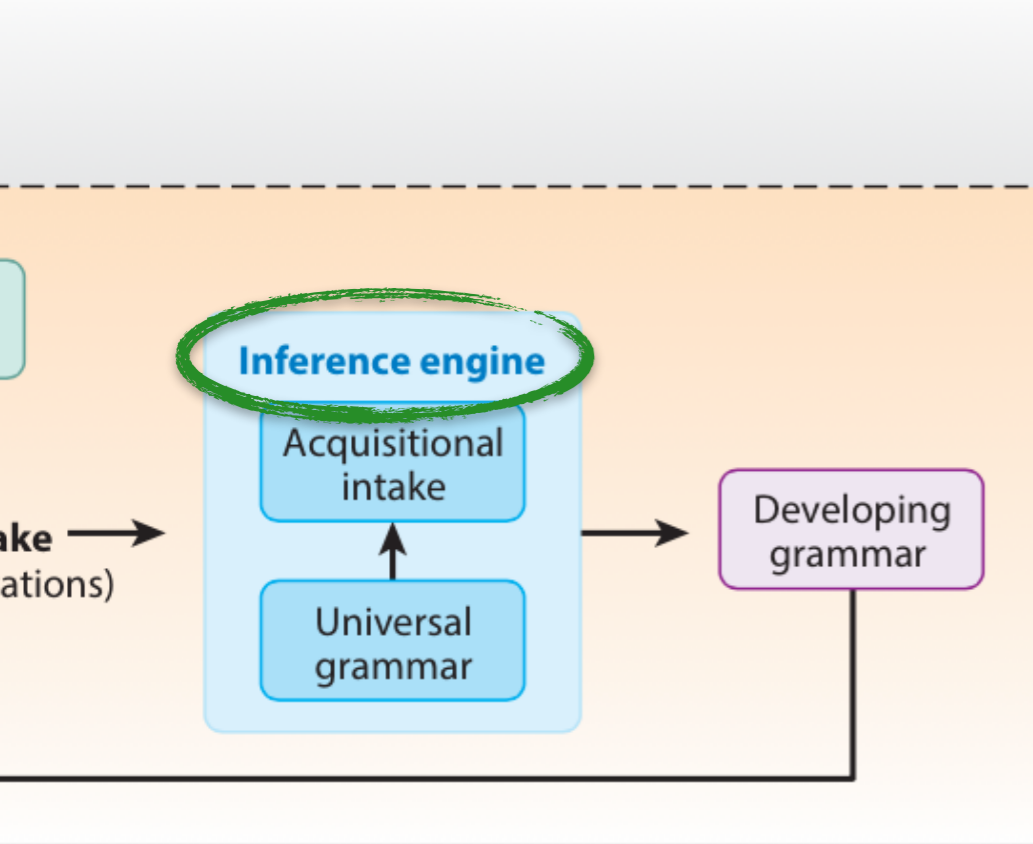

Goal: Model the developmental trajectory from 3 to 4 to 5 years old

<3yrs <4yrs <5yrs

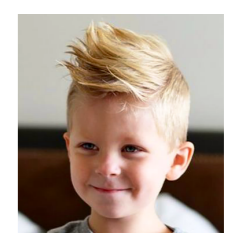

Each verb belongs to some class which determines its linguistic behavior.

...but has a bias for fewer classes.

Objective: Infer verb class

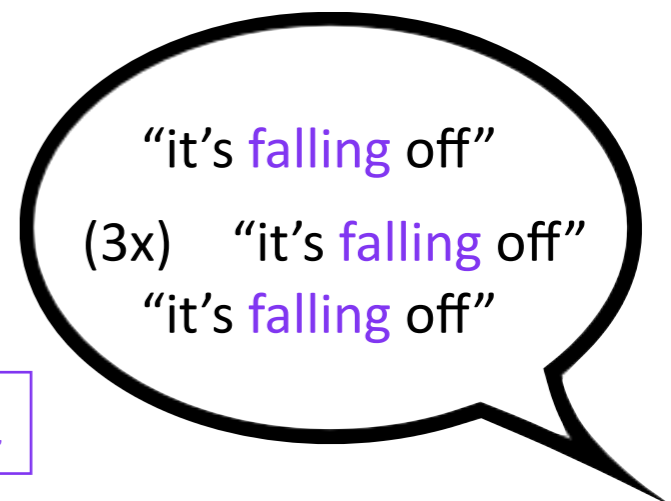
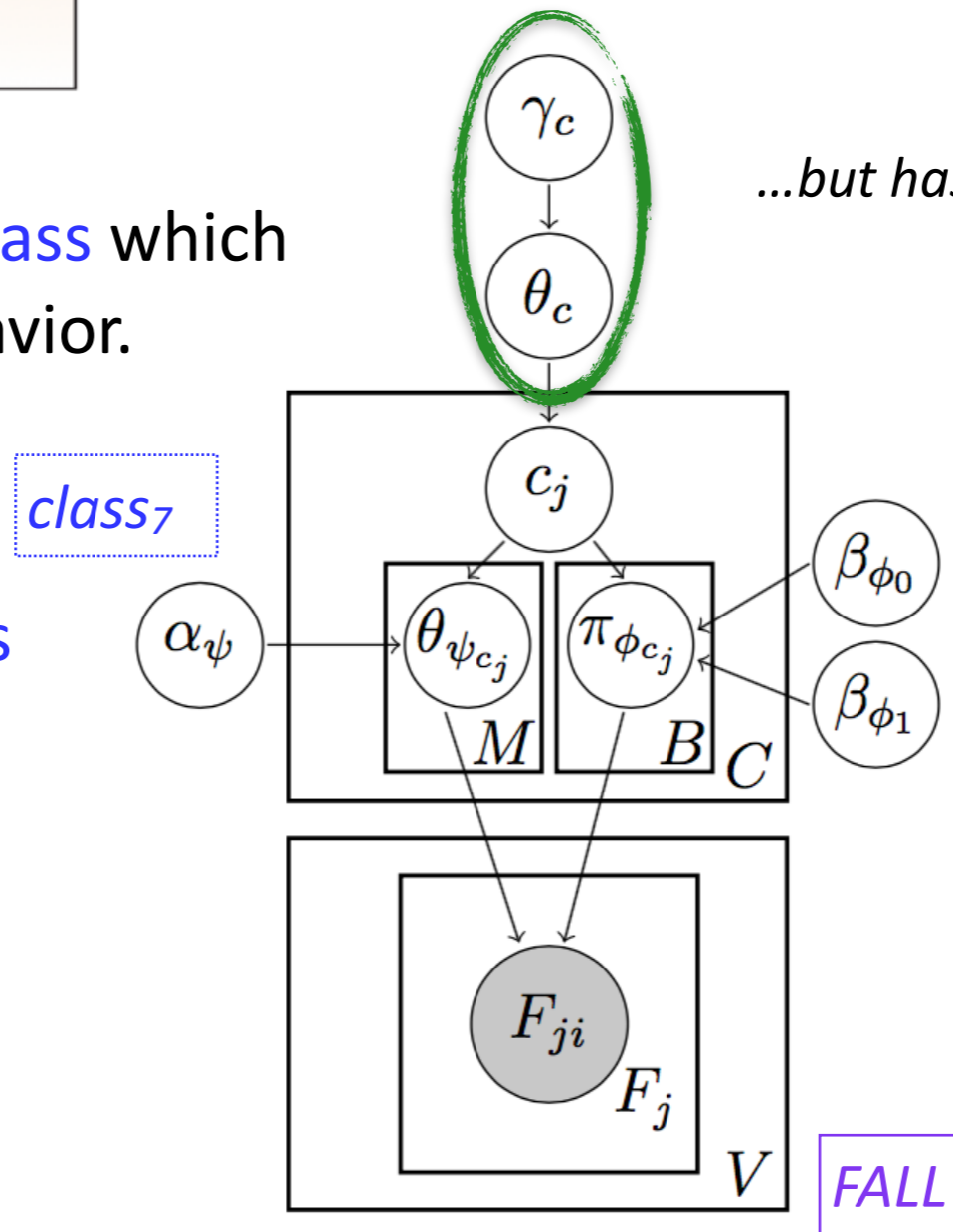

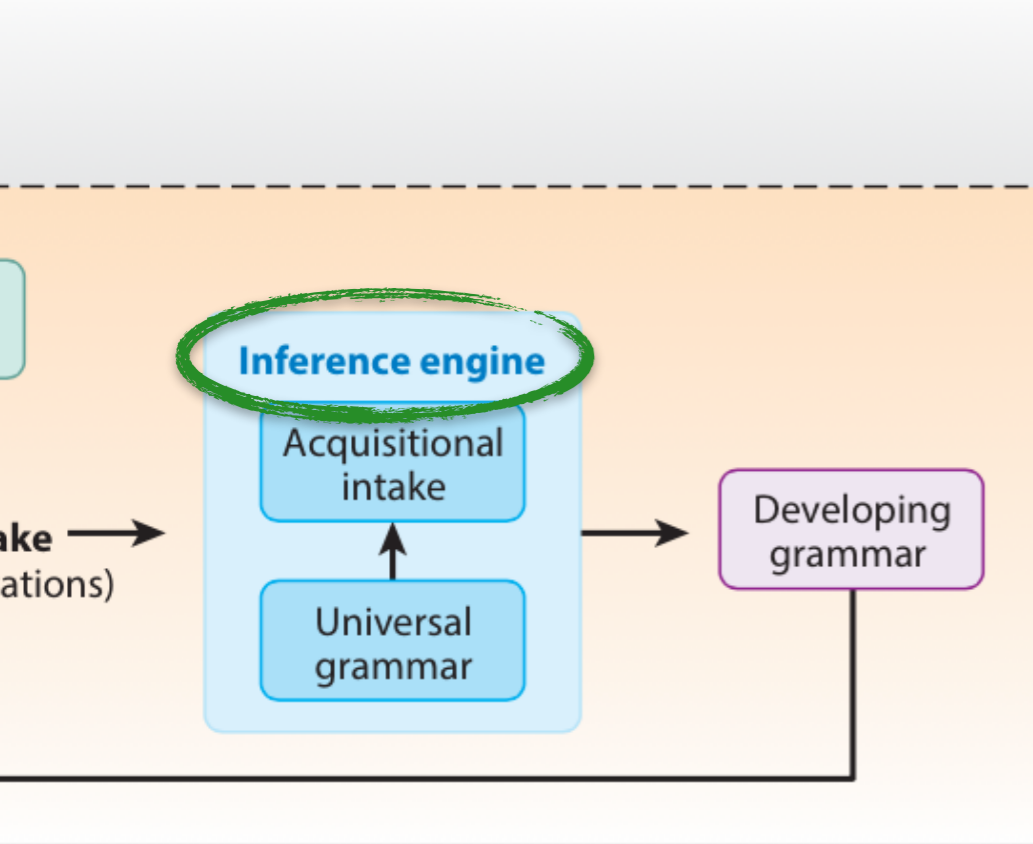

Goal: Model the developmental trajectory from 3 to 4 to 5 years old

<3yrs <4yrs <5yrs

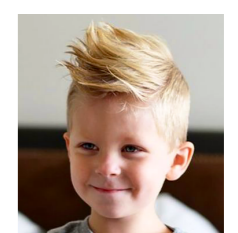

Binary choices:

+animate



-animate



Subject Object Indirect Object

movement?

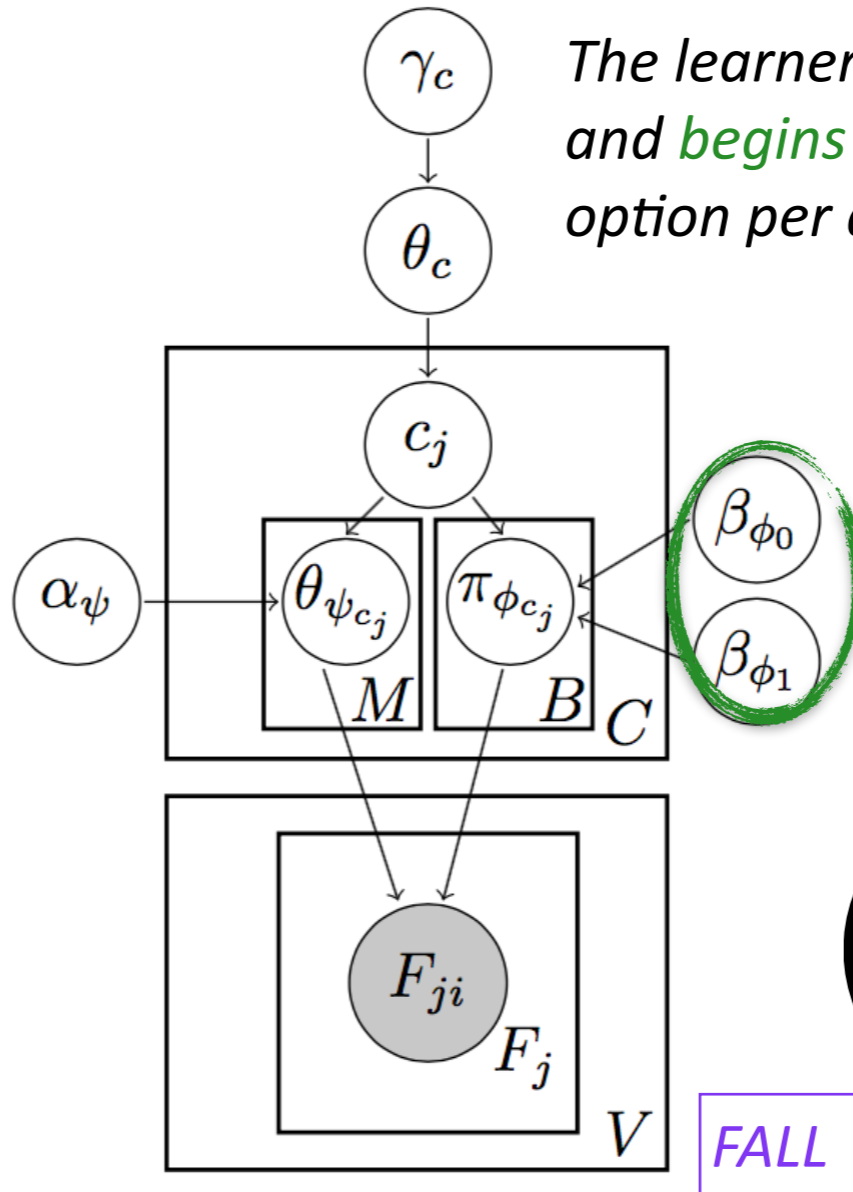

The learner infers these probabilities, and begins with no bias towards either option per class.

class₇

+anim	Subject	-anim
0.3		0.7

-anim
 "it's falling off"
 (3x) "it's falling off"
 "it's falling off"

FALL

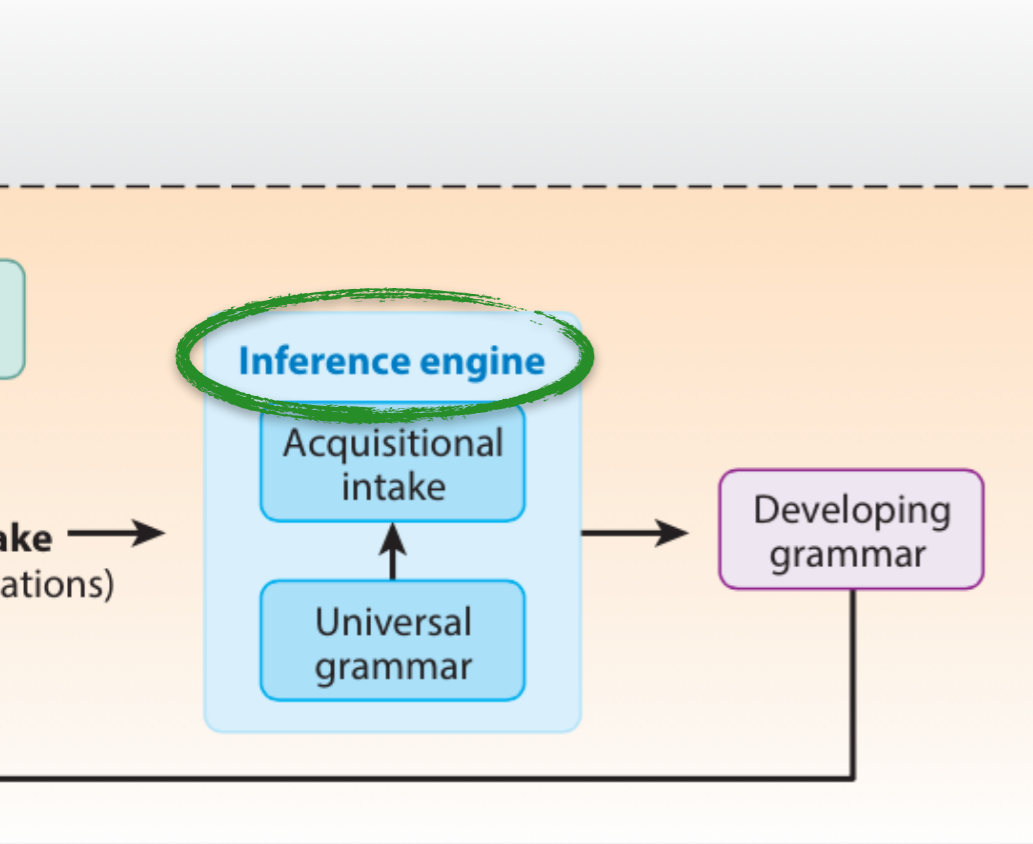

Goal: Model the developmental trajectory from 3 to 4 to 5 years old

<3yrs <4yrs <5yrs

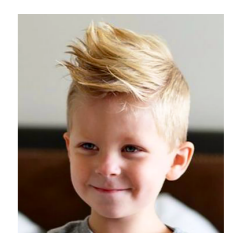

The learner infers these probabilities, and begins with no bias towards any option per class.

Multinomial choices:



Agent > Experiencer > NP V PRT
 Theme > Patient >
 (Source, Goal, Instrument)

Subject Object Indirect Object

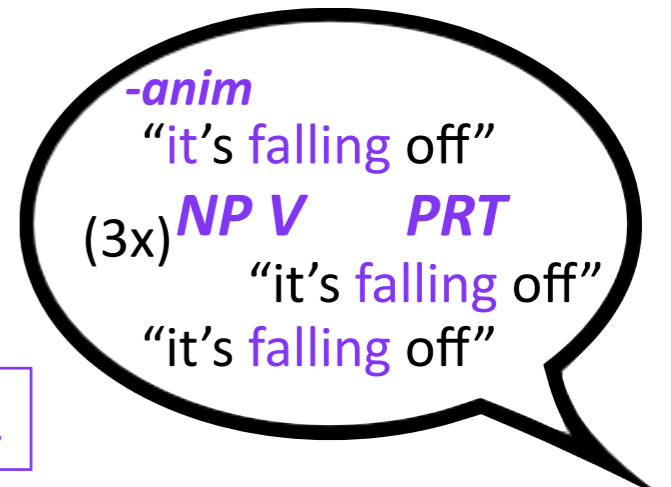
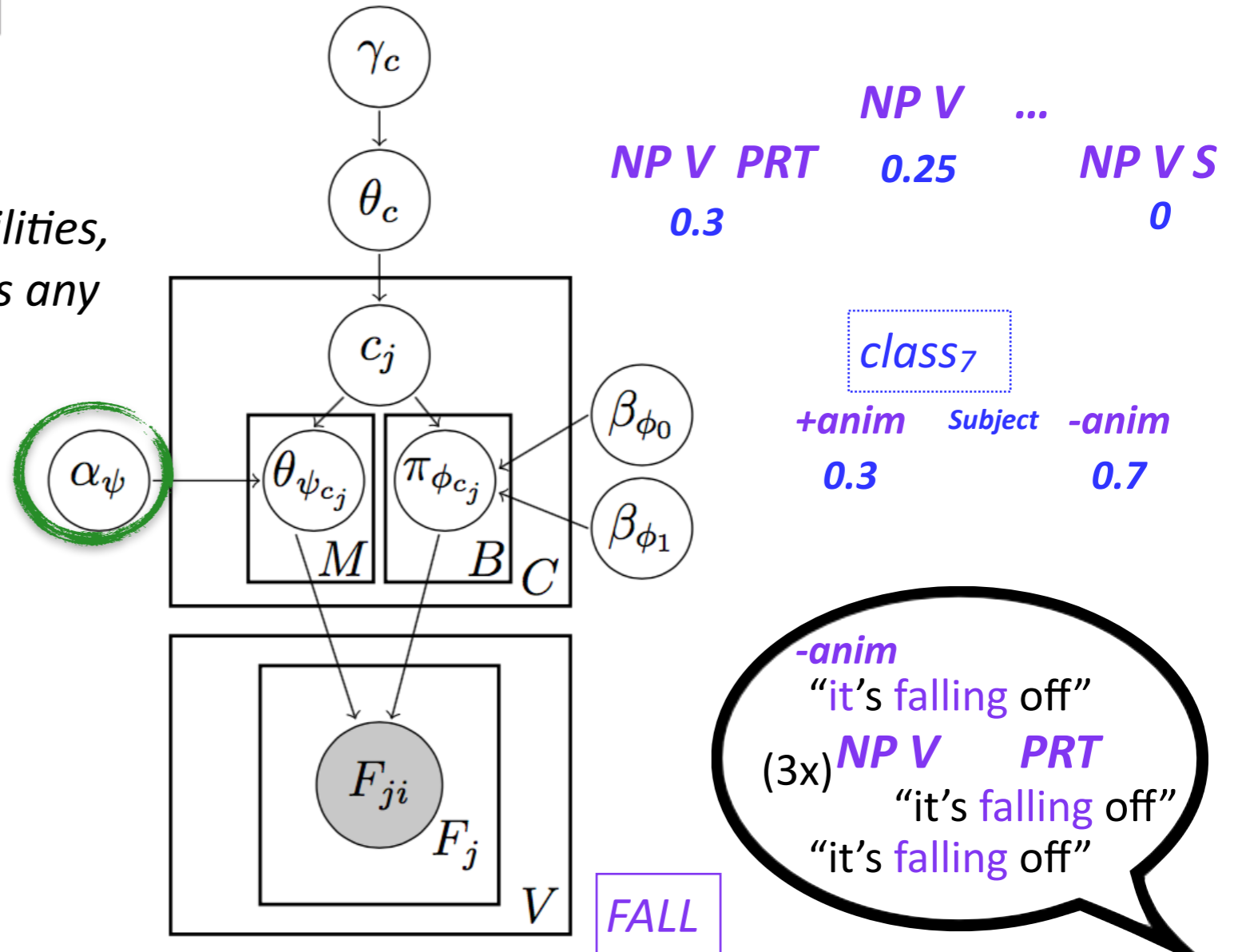

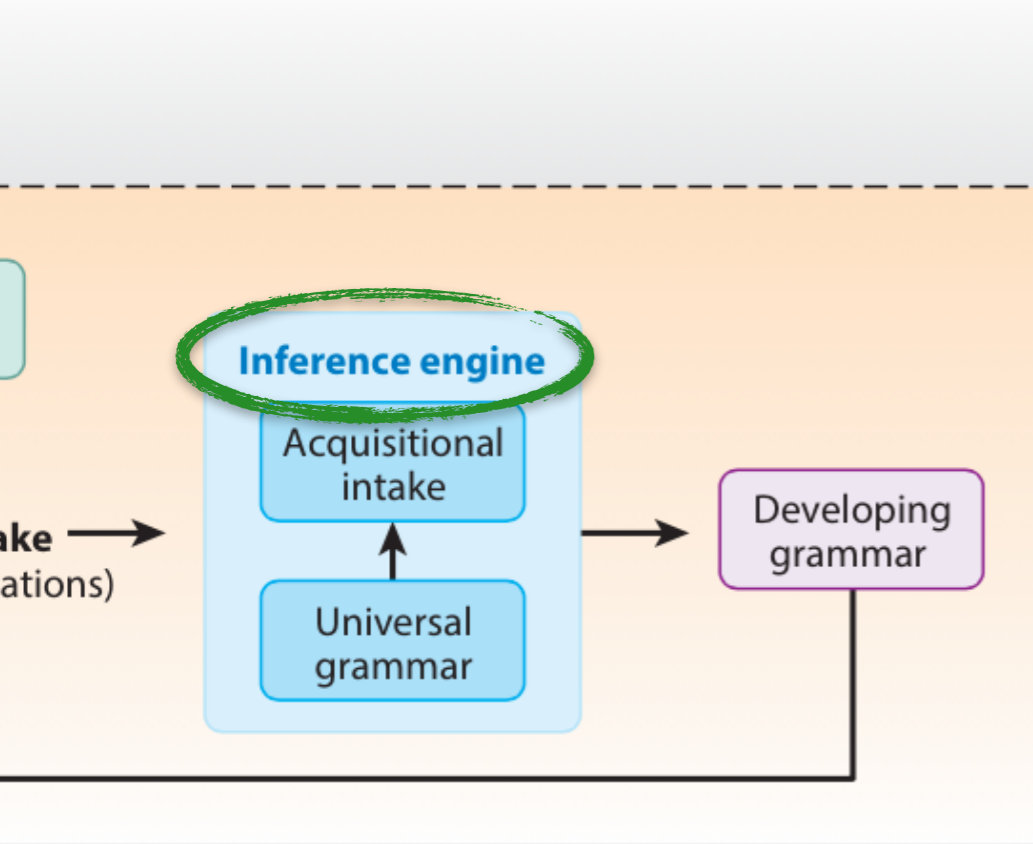

Goal: Model the developmental trajectory from 3 to 4 to 5 years old

<3yrs <4yrs <5yrs

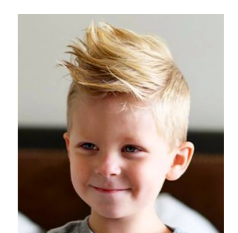

Inference: The learner forms different classes because the characteristics are sufficiently different for each class.

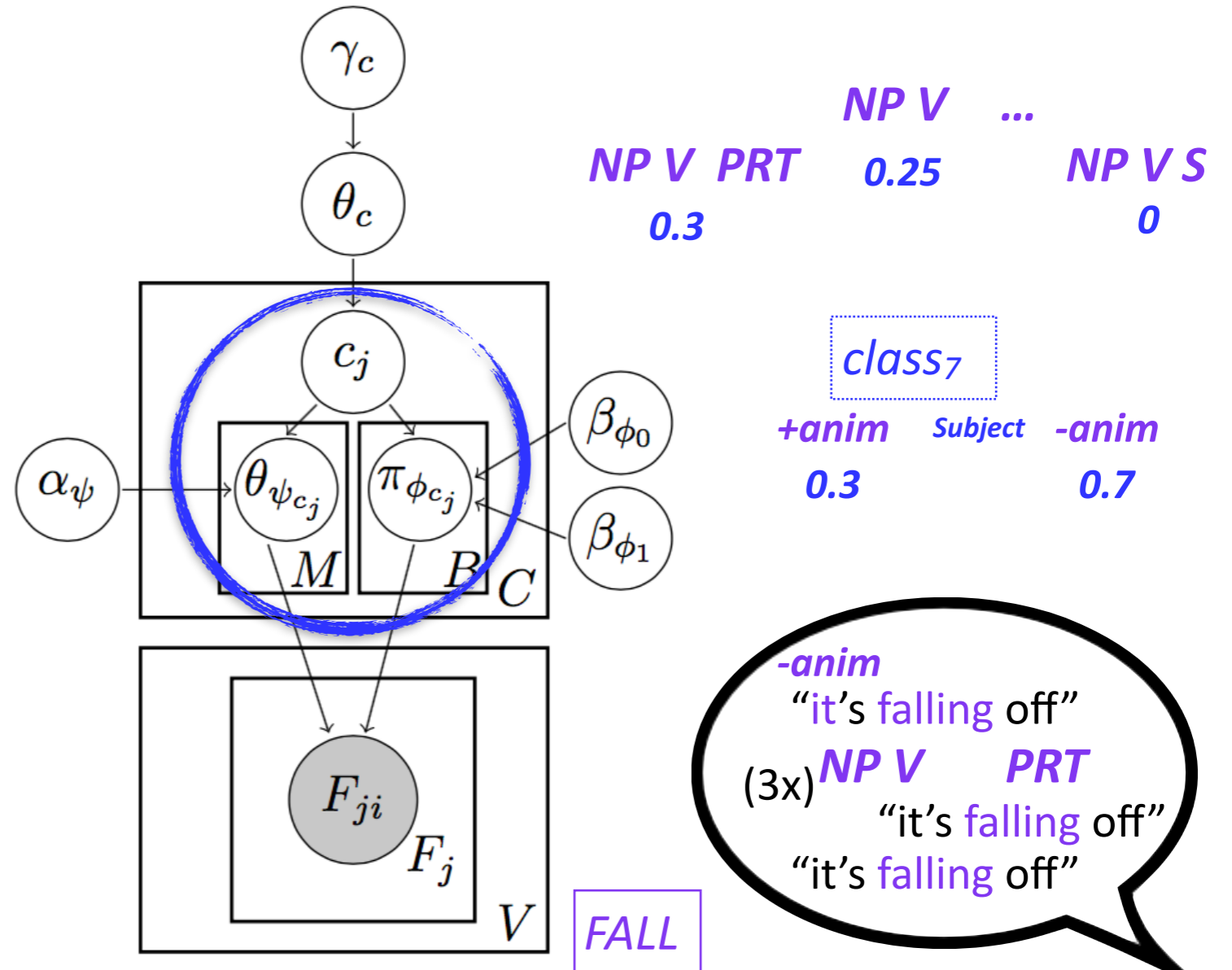

"it's falling off"

"it's falling off"

"it's falling off"

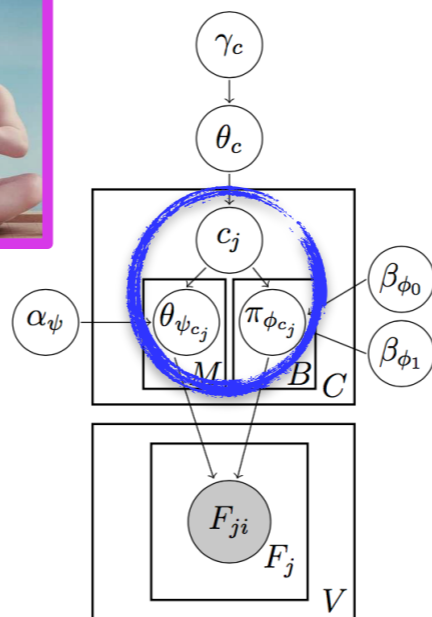
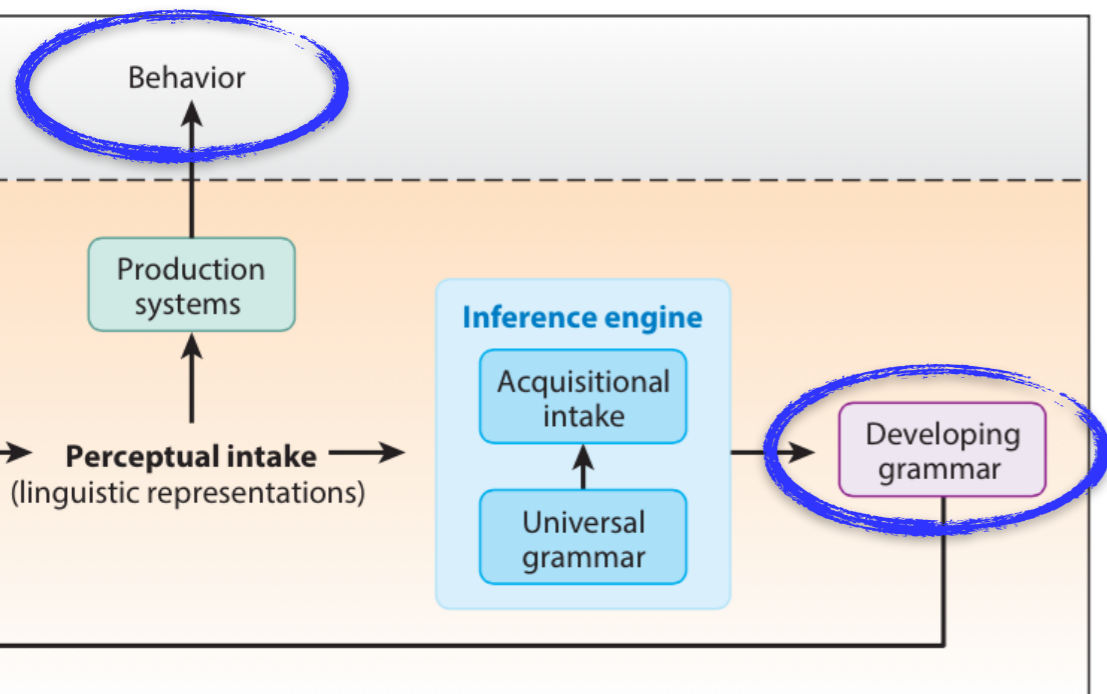

Goal: Model the developmental trajectory from 3 to 4 to 5 years old

<3yrs <4yrs <5yrs



verb classes

Survey of 32 experimental studies on children's production and comprehension of specific verbs



Passives: Maratsos 1974, Maratsos et al. 1985, Gordon & Chafetz 1990, O'Brien et al. 2006, Crain et al. 2009, Messenger et al. 2009, Nguyen et al. 2016

"It was ___-en."
done-to

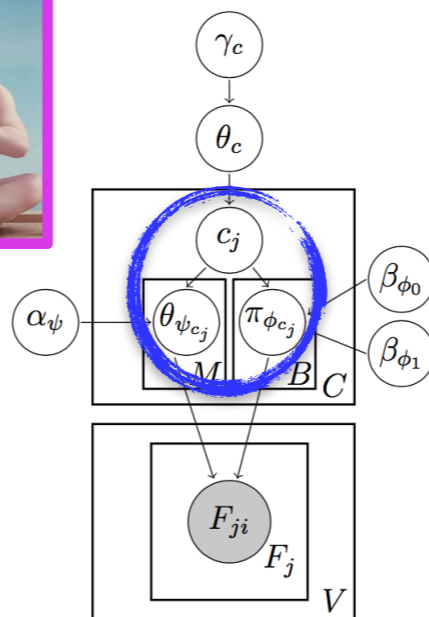
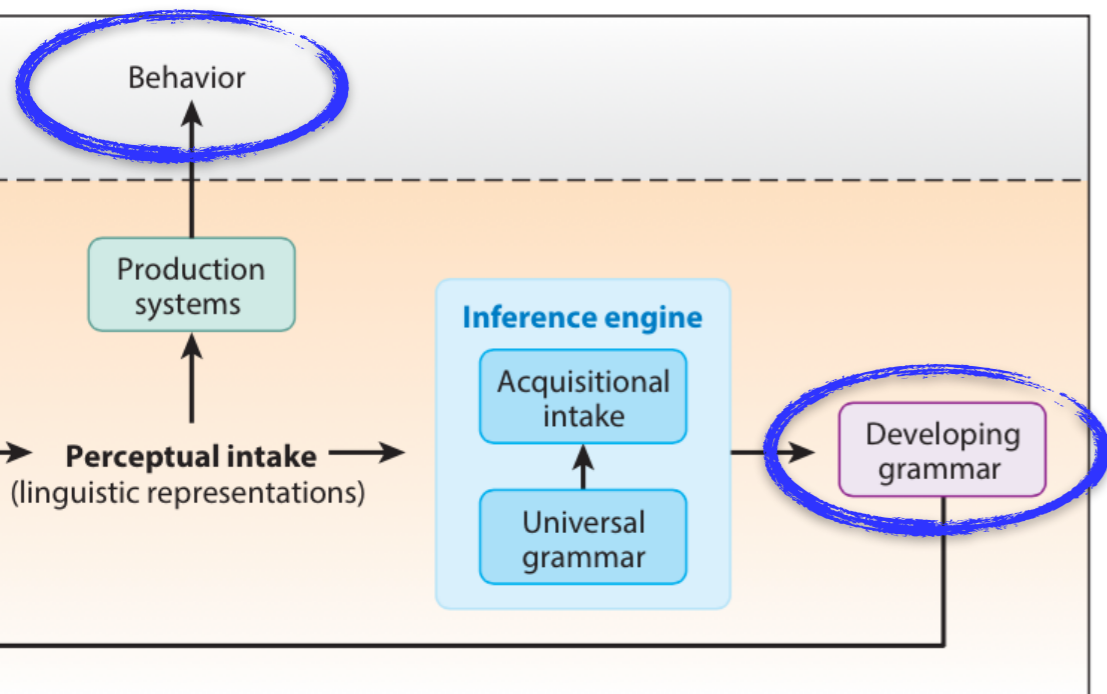

Goal: Model the developmental trajectory from 3 to 4 to 5 years old

<4yrs

<5yrs

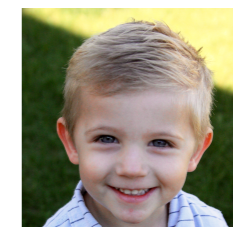

verb classes

Survey of 32 experimental studies on children's production and comprehension of specific verbs



Passives: Maratsos 1974, Maratsos et al. 1985, Gordon & Chafetz 1990, O'Brien et al. 2006, Crain et al. 2009, Messenger et al. 2009, Nguyen et al. 2016

"It was ___-en."
done-to

3yrs



+ = hit, see, ...

- = know, remember, ...

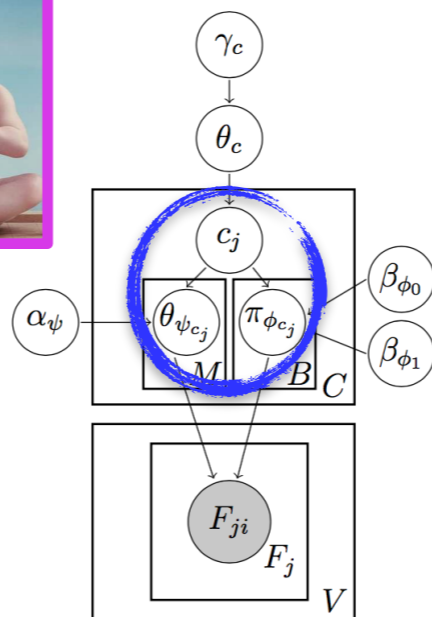
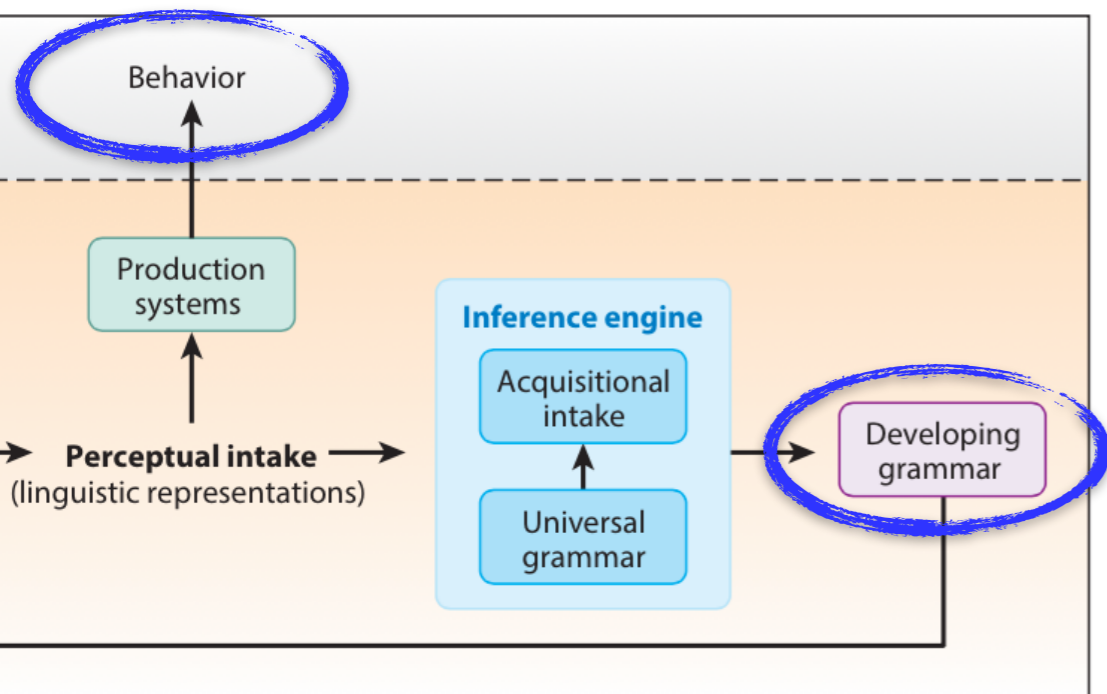

Goal: Model the developmental trajectory from 3 to 4 to 5 years old

<3yrs

<5yrs



verb classes

Survey of 32 experimental studies on children's production and comprehension of specific verbs



Passives: Maratsos 1974, Maratsos et al. 1985, Gordon & Chafetz 1990, O'Brien et al. 2006, Crain et al. 2009, Messenger et al. 2009, Nguyen et al. 2016

"It was ___-en."
done-to

4yrs



+ = hit, scare, see, ...

- = know, love, remember, ...

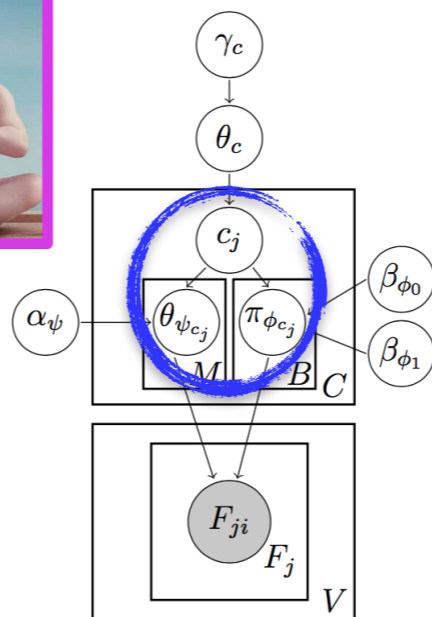
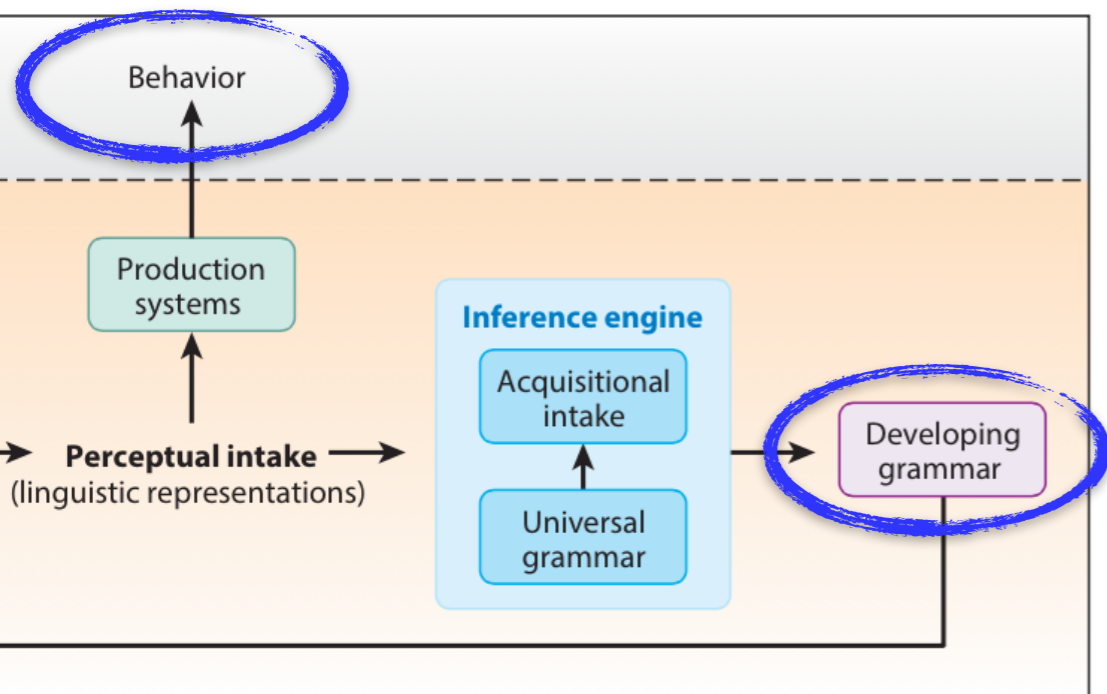

Goal: Model the developmental trajectory from 3 to 4 to 5 years old

<3yrs <4yrs



verb classes

Survey of 32 experimental studies on children's production and comprehension of specific verbs



Passives: Maratsos 1974, Maratsos et al. 1985, Gordon & Chafetz 1990, O'Brien et al. 2006, Crain et al. 2009, Messenger et al. 2009, Nguyen et al. 2016

"It was ___-en."
done-to

5yrs



+ = hit, love, scare, see, ...
- = know, remember, ...

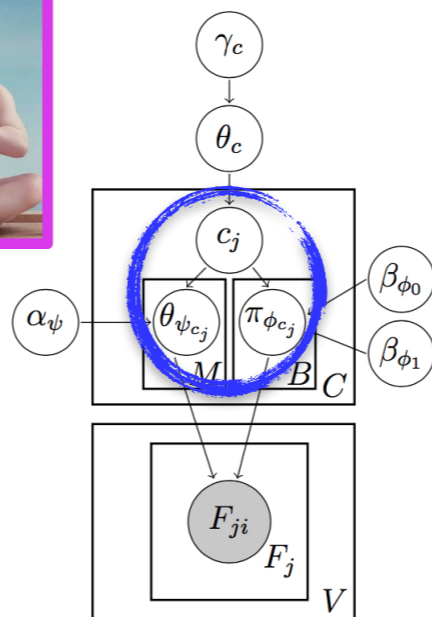
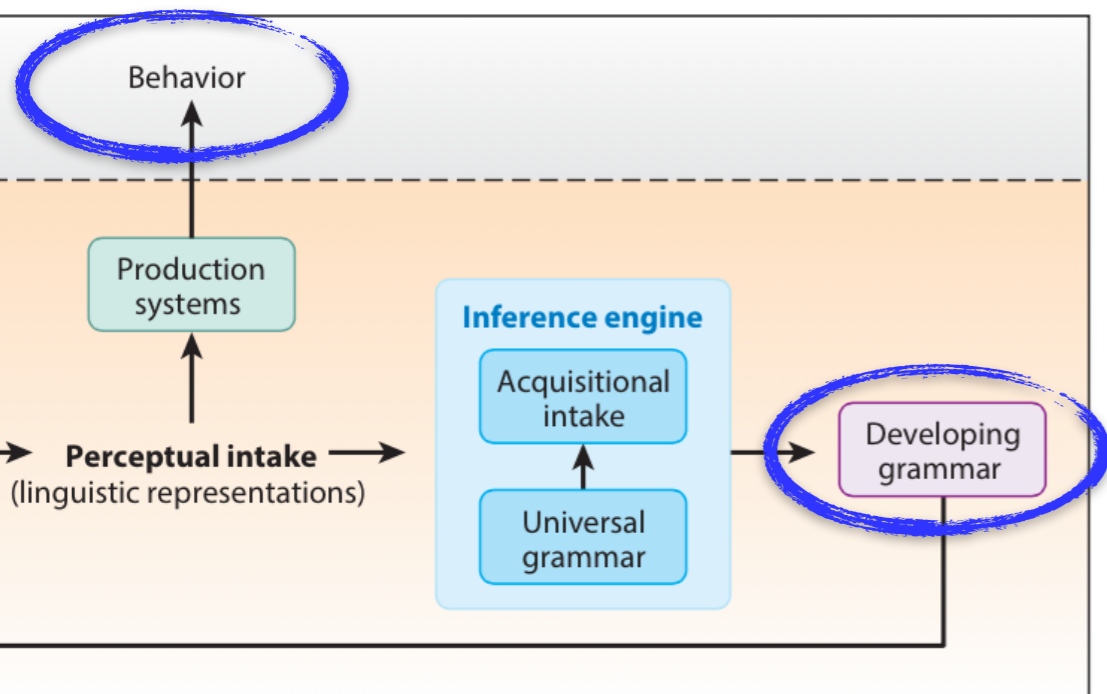

Goal: Model the developmental trajectory from 3 to 4 to 5 years old

<3yrs

<4yrs

<5yrs



verb classes

Survey of 32 experimental studies on children's production and comprehension of specific verbs



Ditransitives: Gropen et al. 1989, Snedeker & Huang in press, Campbell & Tomasello 2001, Huttenlocher et al. 2004, Conwell & Demuth 2007, Thothathiri & Snedeker 2008

"Jack ___ Lily the thing."

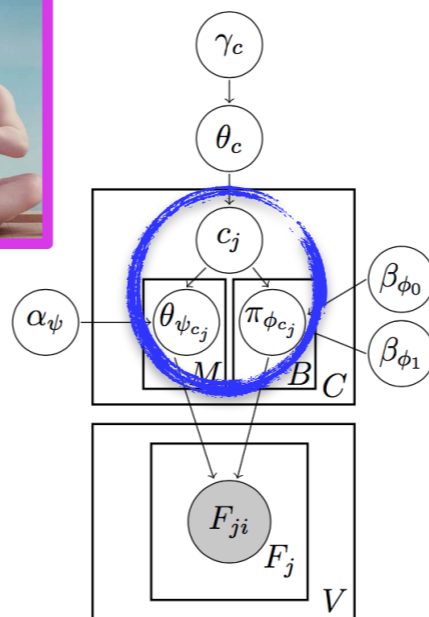
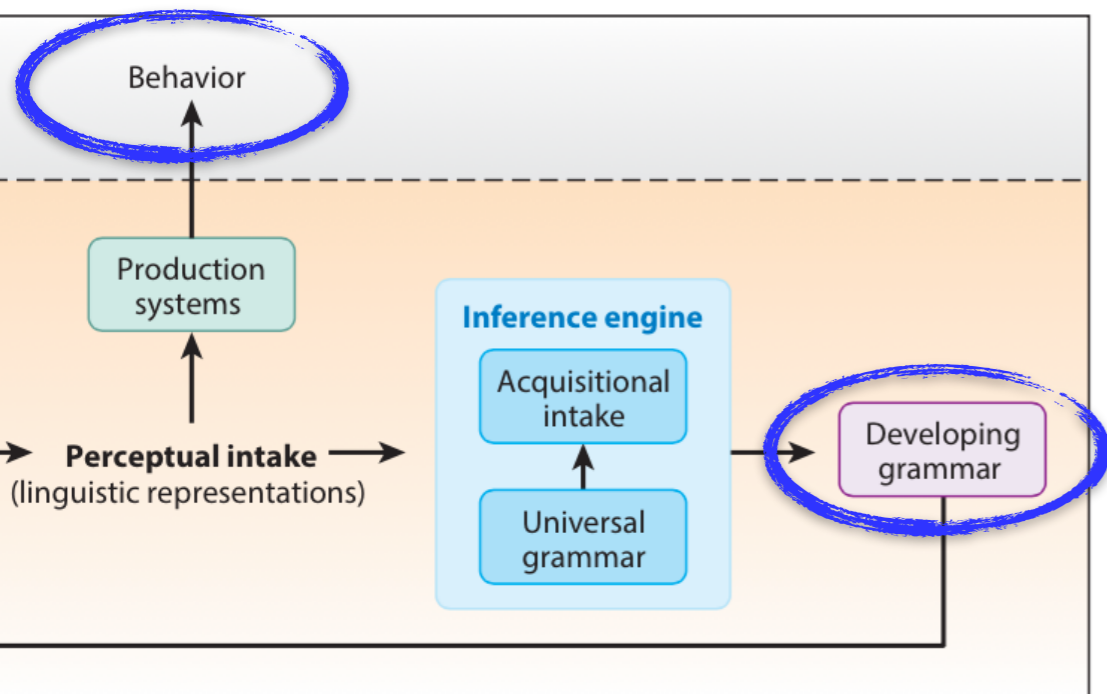

Goal: Model the developmental trajectory from 3 to 4 to 5 years old

<4yrs

<5yrs

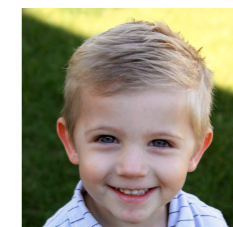

verb classes

Survey of 32 experimental studies on children's production and comprehension of specific verbs



Ditransitives: Gropen et al. 1989, Snedeker & Huang in press, Campbell & Tomasello 2001, Huttenlocher et al. 2004, Conwell & Demuth 2007, Thothathiri & Snedeker 2008

"Jack ___ Lily the thing."

3yrs



+ = give, read, *say, ...

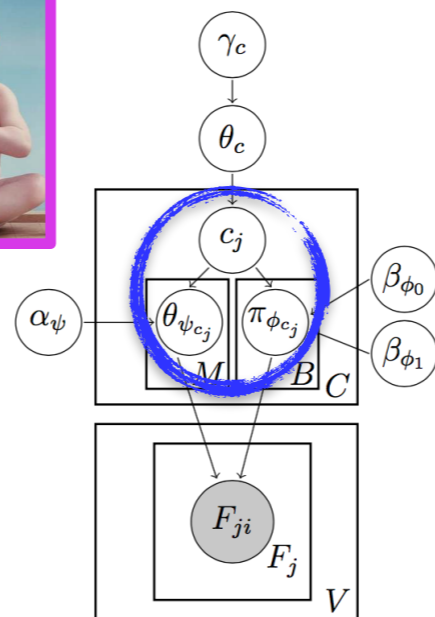
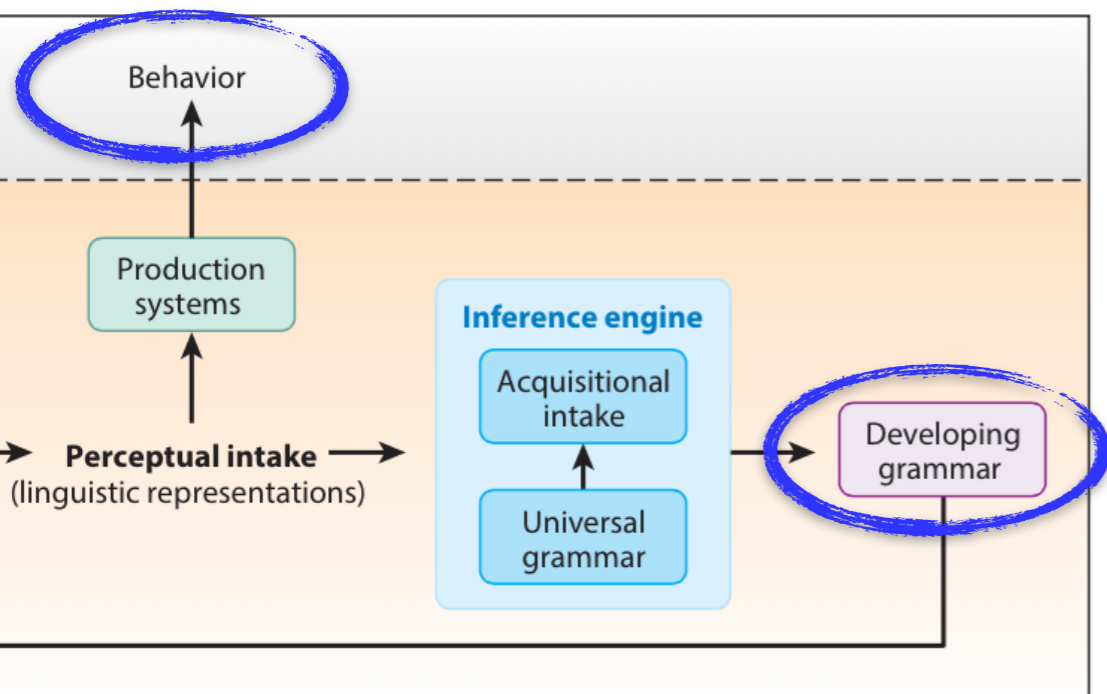

Goal: Model the developmental trajectory from 3 to 4 to 5 years old

<3yrs

<5yrs



verb classes

Survey of 32 experimental studies on children's production and comprehension of specific verbs



Ditransitives: Gropen et al. 1989, Snedeker & Huang in press, Campbell & Tomasello 2001, Huttenlocher et al. 2004, Conwell & Demuth 2007, Thothathiri & Snedeker 2008

"Jack ___ Lily the thing."

4yrs



+ = give, read, *say, teach, ...

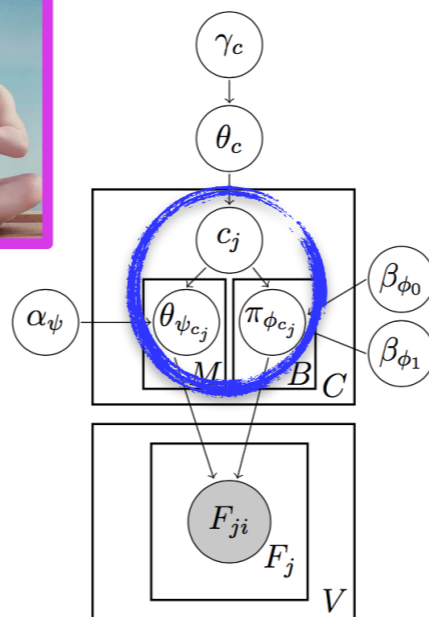
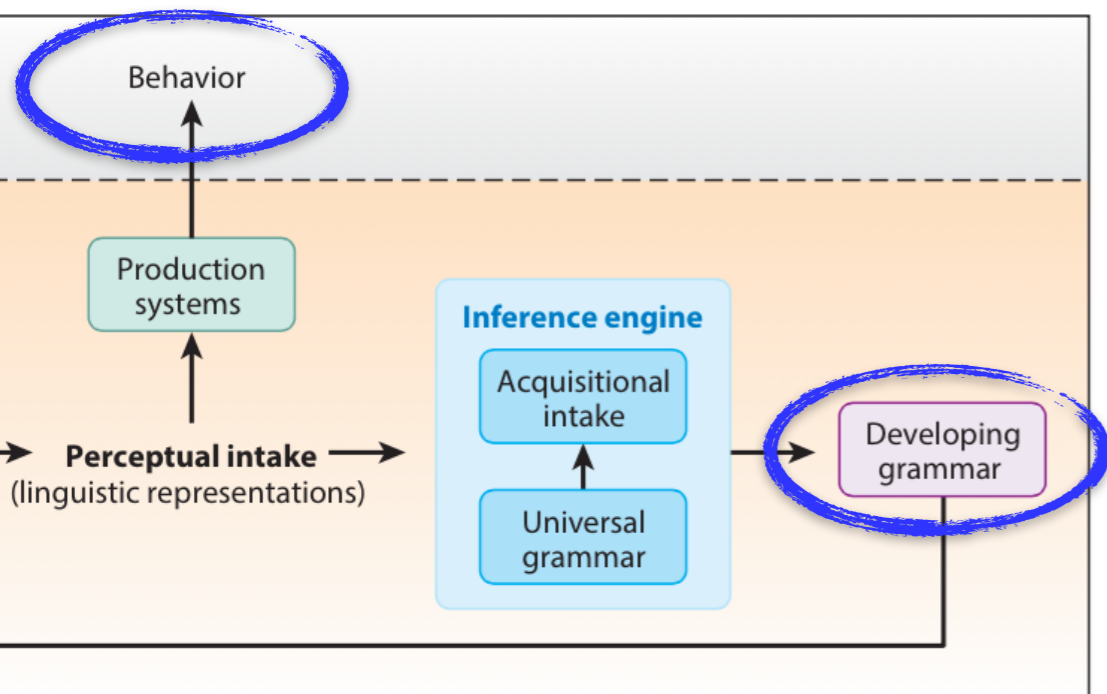

Goal: Model the developmental trajectory from 3 to 4 to 5 years old

<3yrs

<4yrs



verb classes

Survey of 32 experimental studies on children's production and comprehension of specific verbs



Ditransitives: Gropen et al. 1989, Snedeker & Huang in press, Campbell & Tomasello 2001, Huttenlocher et al. 2004, Conwell & Demuth 2007, Thothathiri & Snedeker 2008

“Jack ___ Lily the thing.”

5yrs



+ = ask, give, read, *say, teach, ...

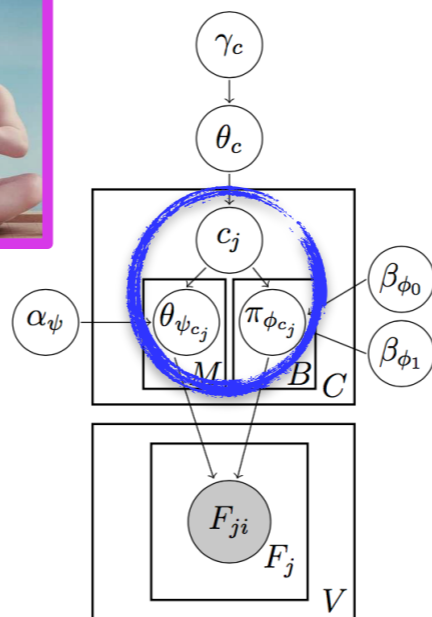
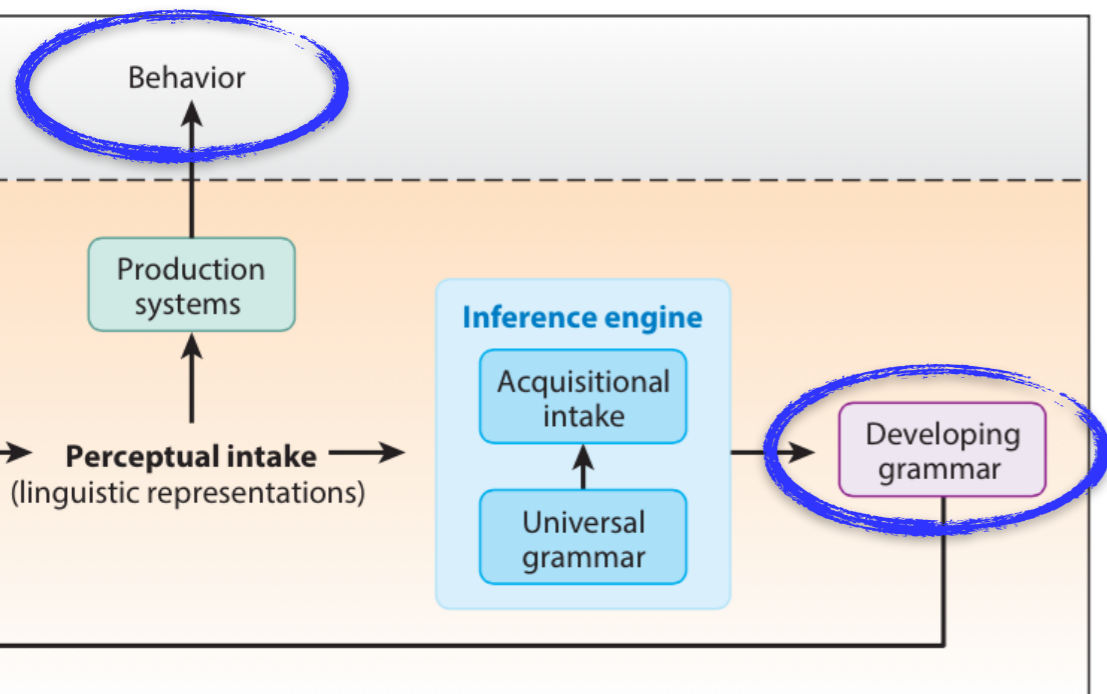

Goal: Model the developmental trajectory from 3 to 4 to 5 years old

<3yrs

<4yrs

<5yrs



verb classes

Survey of 32 experimental studies on children's production and comprehension of specific verbs



Unaccusatives: Déprez & Pierce 1993, Snyder & Stromwold 1997, Gelman & Koenig 2001, Bunger & Lidz 2004, Bunger & Lidz 2008

"It ____."
done-to

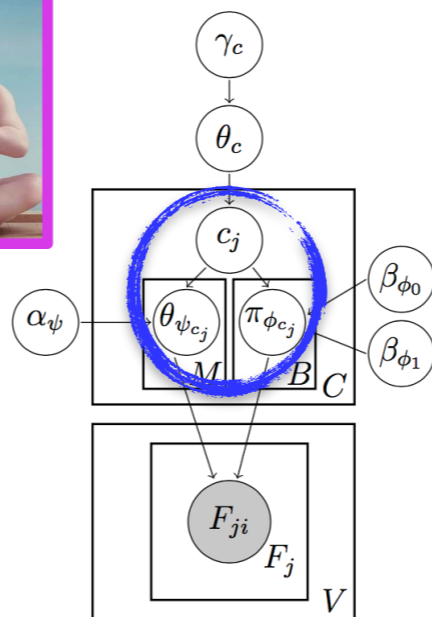
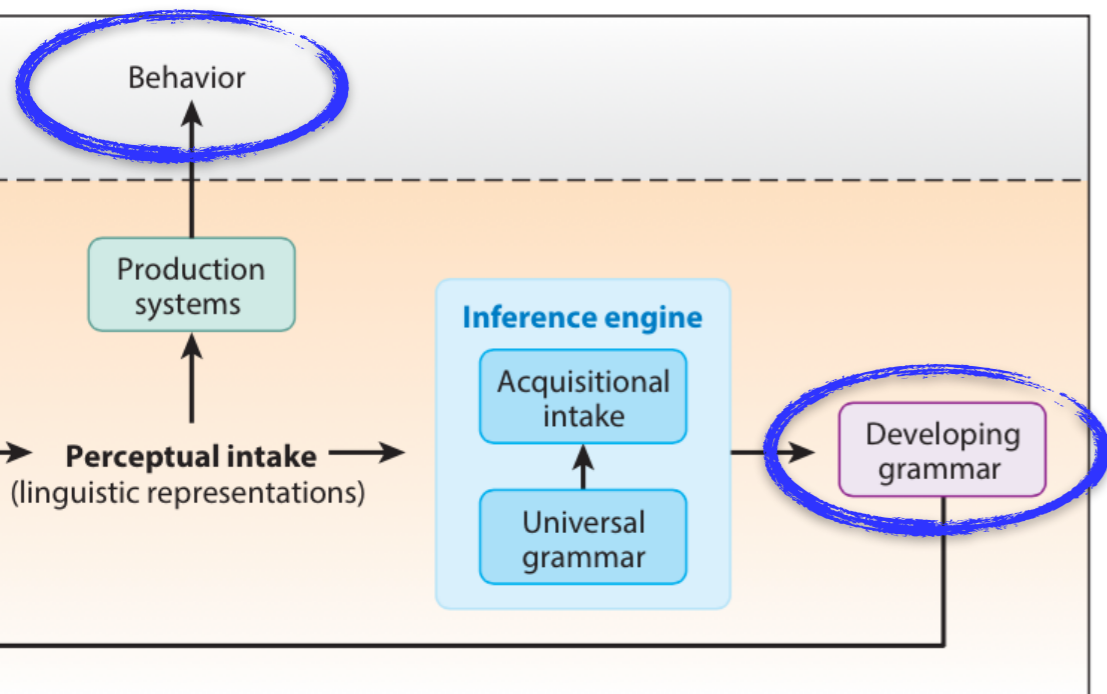

Goal: Model the developmental trajectory from 3 to 4 to 5 years old

<4yrs

<5yrs

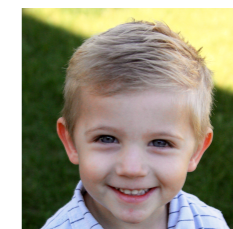

verb classes

Survey of 32 experimental studies on children's production and comprehension of specific verbs



Unaccusatives: Déprez & Pierce 1993, Snyder & Stromwold 1997, Gelman & Koenig 2001, Bungler & Lidz 2004, Bungler & Lidz 2008

"It ____."
done-to

3yrs



+ = break, fall, ...

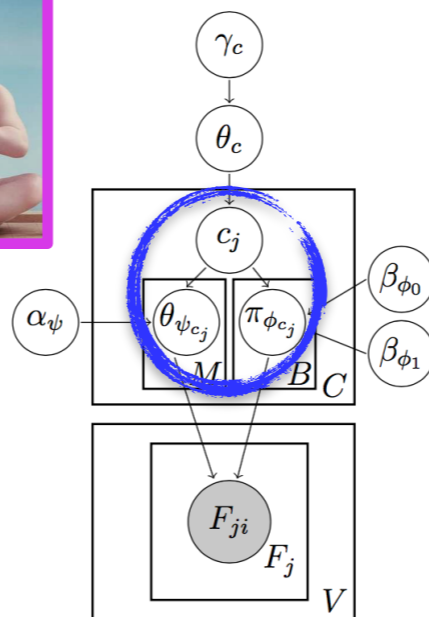
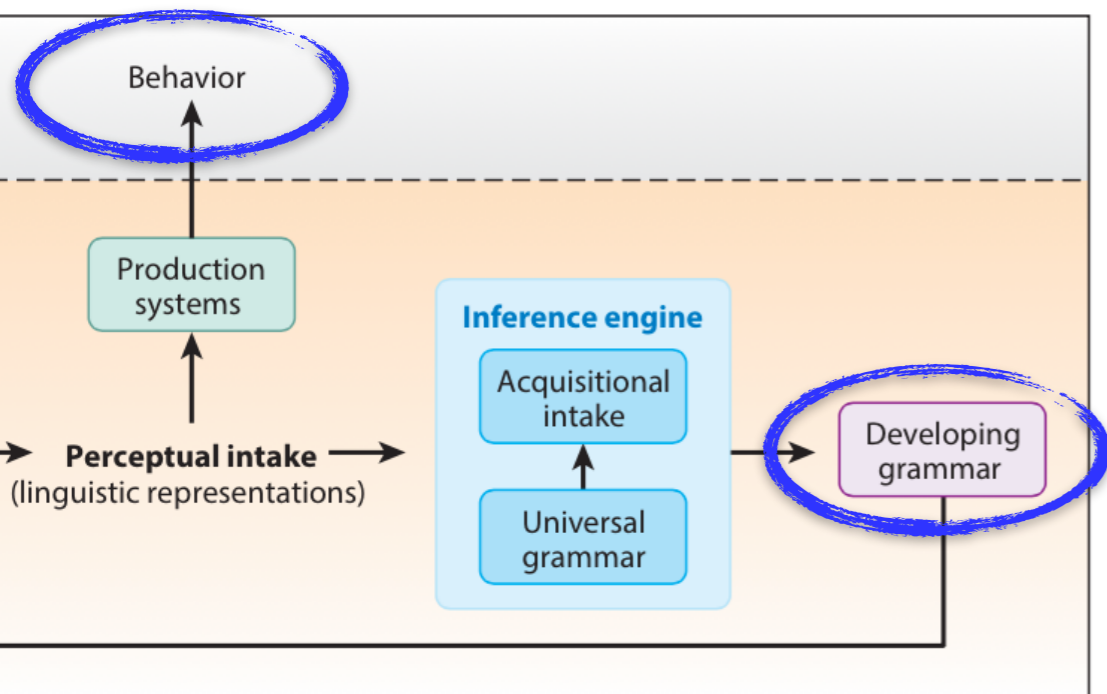

Goal: Model the developmental trajectory from 3 to 4 to 5 years old

<3yrs

<4yrs

<5yrs

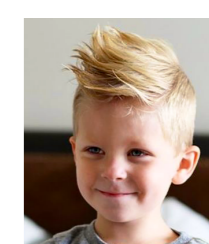

verb classes

Survey of 32 experimental studies on children's production and comprehension of specific verbs



Control object & Raising object: Kirby 2009a, Kirby 2009b, Kirby 2010, Becker 2014

Control object

"I ___ him to leave."

done-recipient (main)

doer (embedded)

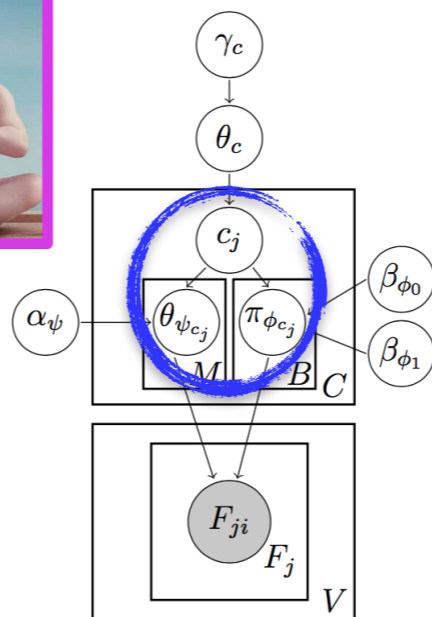
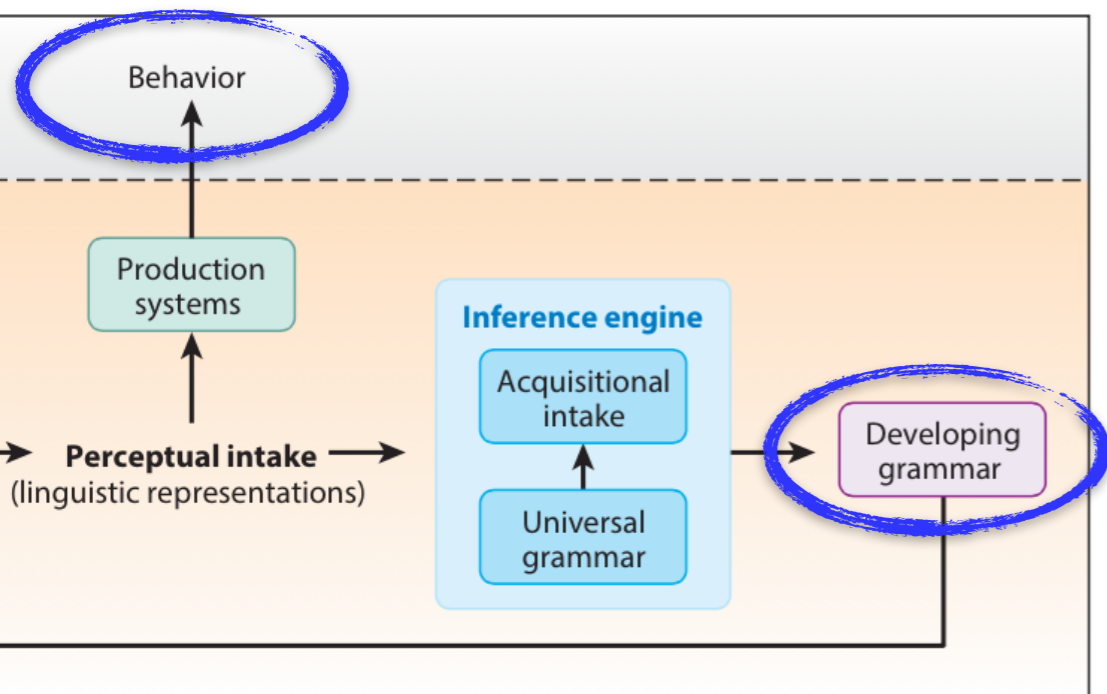

Goal: Model the developmental trajectory from 3 to 4 to 5 years old <3yrs



verb classes

Survey of 32 experimental studies on children's production and comprehension of specific verbs



Control object & Raising object: Kirby 2009a, Kirby 2009b, Kirby 2010, Becker 2014

Control object

"I ___ him to leave."
done-recipient (main)
doer (embedded)

4yrs

5yrs

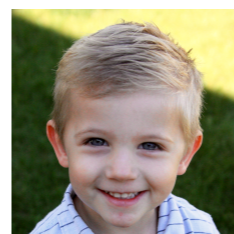

+= ask, tell

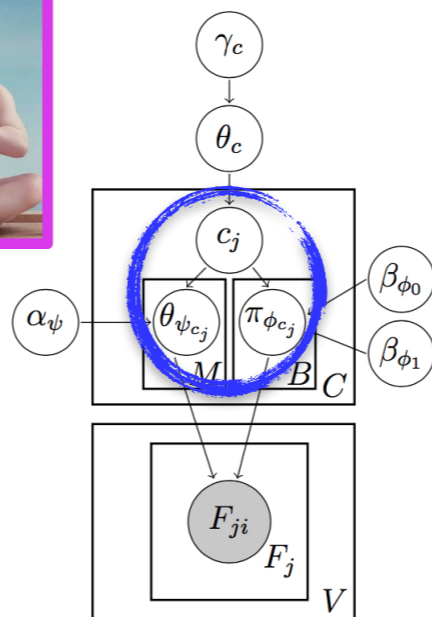
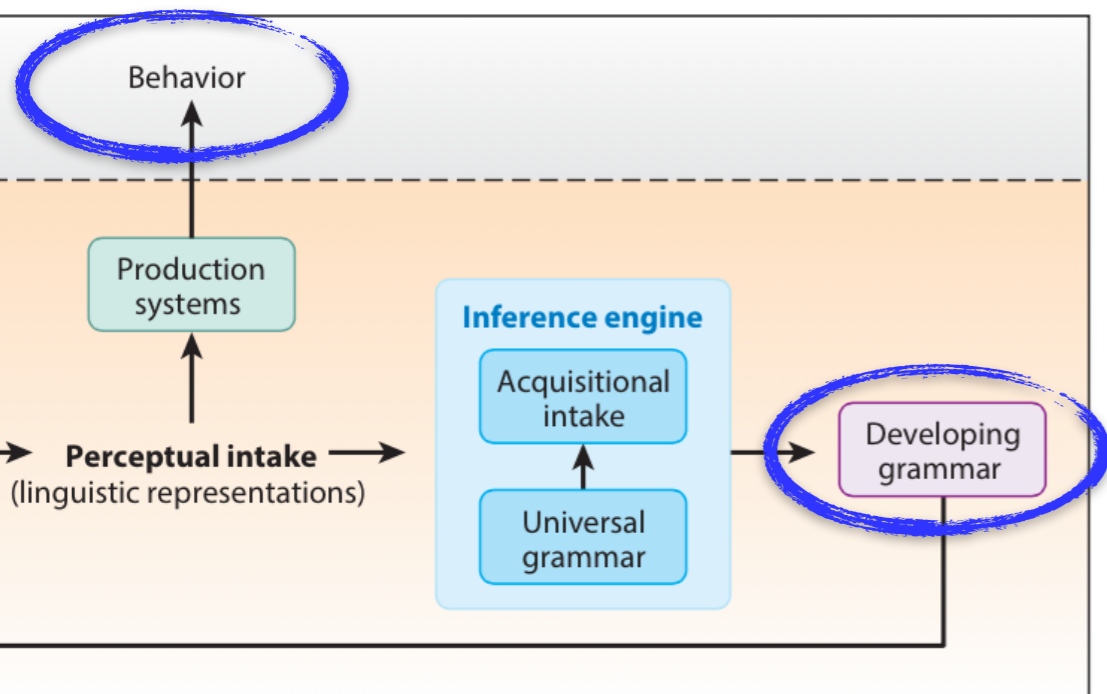

Goal: Model the developmental trajectory from 3 to 4 to 5 years old <3yrs



verb classes

Survey of 32 experimental studies on children's production and comprehension of specific verbs



Control object & Raising object: Kirby 2009a, Kirby 2009b, Kirby 2010, Becker 2014

Raising object

"I ___ him to leave."
doer (embedded)

4yrs

5yrs

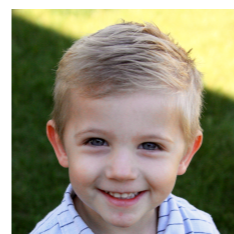

+= need, want

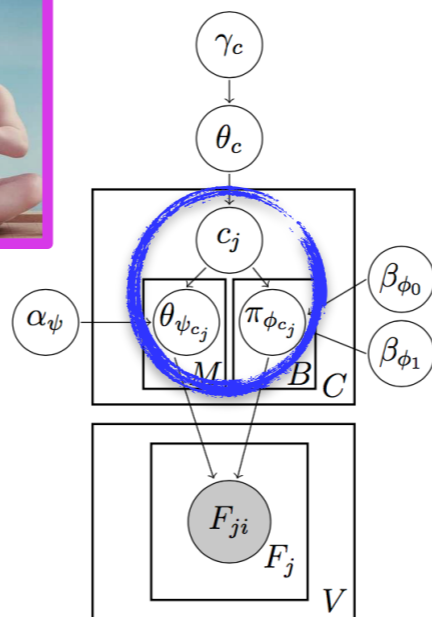
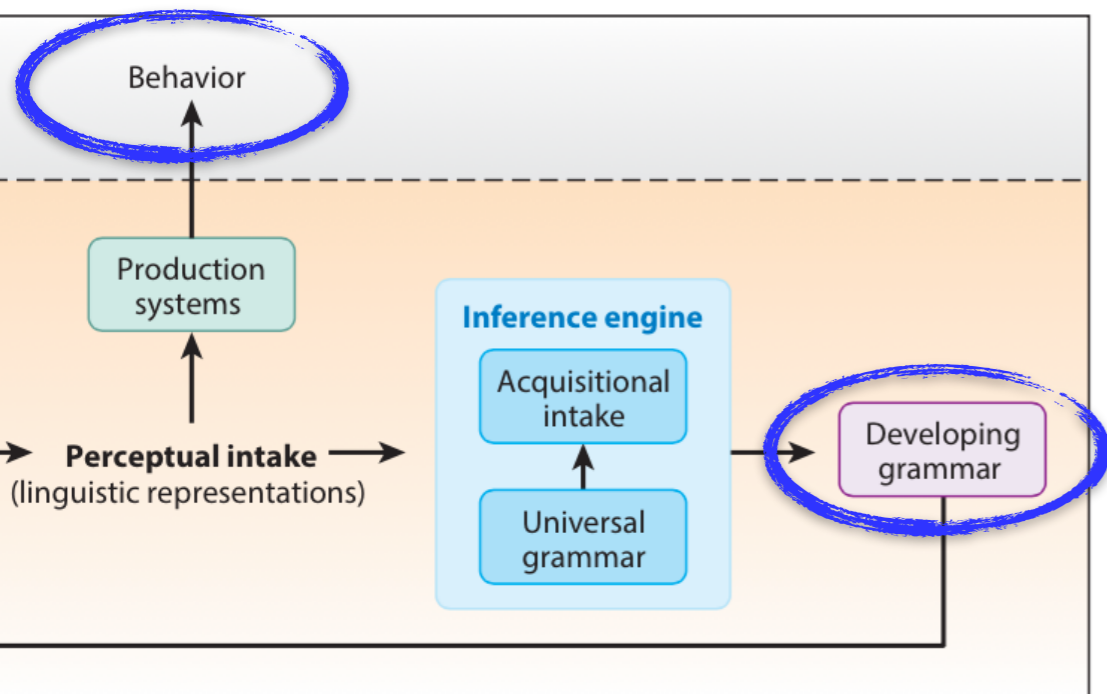

Goal: Model the developmental trajectory from 3 to 4 to 5 years old

<3yrs <4yrs <5yrs

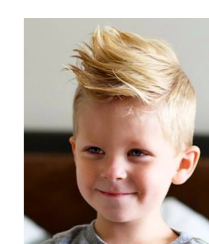

verb classes

Survey of 32 experimental studies on children's production and comprehension of specific verbs



Control subject & Raising subject: Becker 2006, Becker 2007, Becker 2009, Becker 2014

Control subject

"I ___ to leave."
doer (main)
doer (embedded)

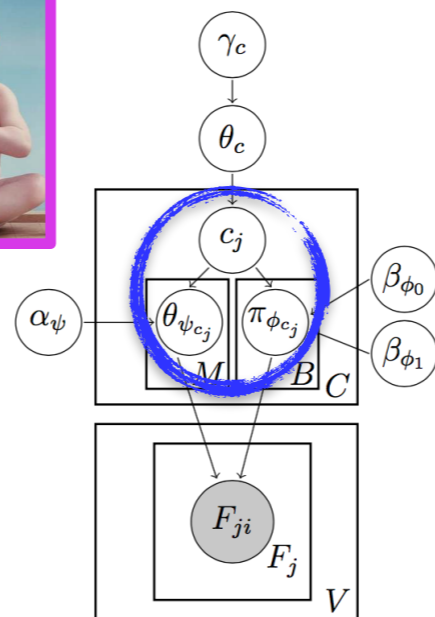
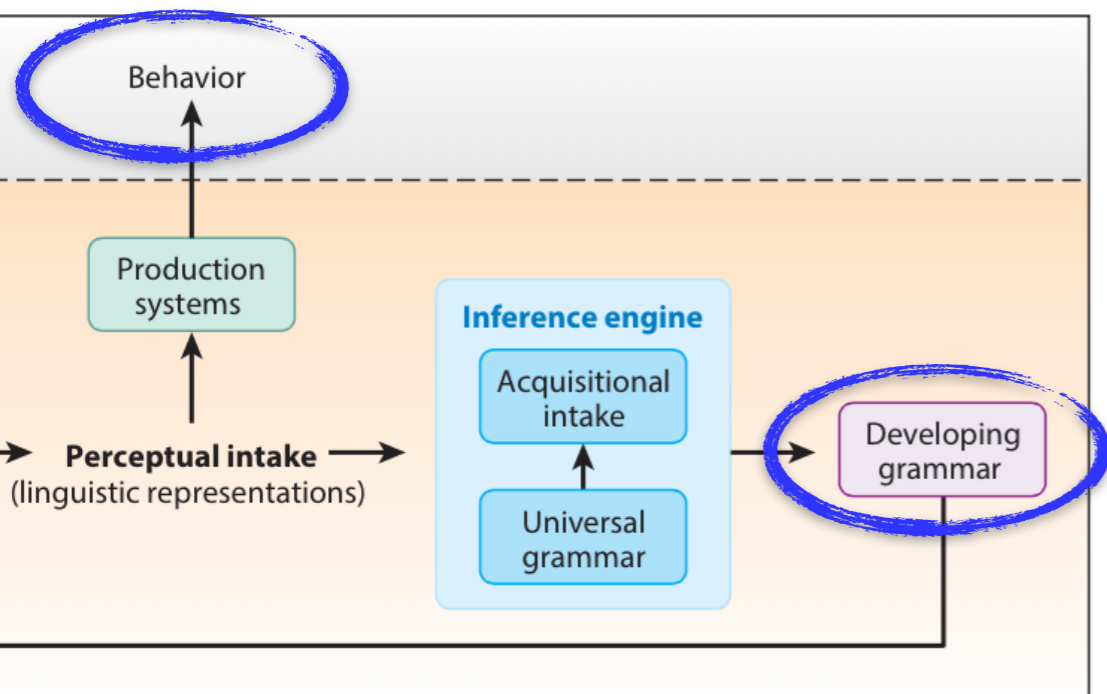

Goal: Model the developmental trajectory from 3 to 4 to 5 years old <3yrs



verb classes

Survey of 32 experimental studies on children's production and comprehension of specific verbs



Control subject & Raising subject: Becker 2006, Becker 2007, Becker 2009, Becker 2014

Control subject

"I ___ to leave."
doer (main)
doer (embedded)

4yrs

5yrs

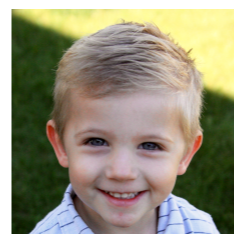

+= try, want

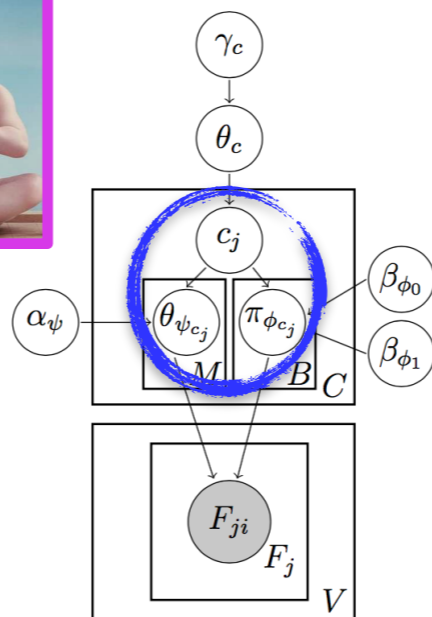
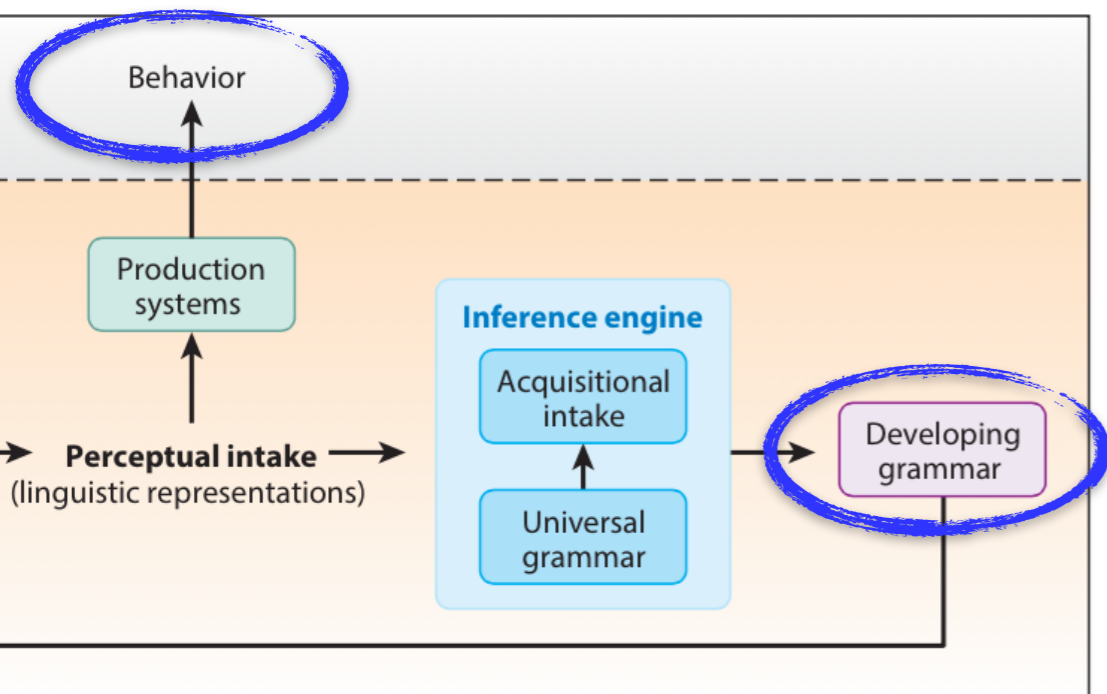

Goal: Model the developmental trajectory from 3 to 4 to 5 years old <3yrs



verb classes

Survey of 32 experimental studies on children's production and comprehension of specific verbs



Control subject & Raising subject: Becker 2006, Becker 2007, Becker 2009, Becker 2014

Raising subject

"I _____ to leave."
doer (embedded)

4yrs

5yrs



+= seem

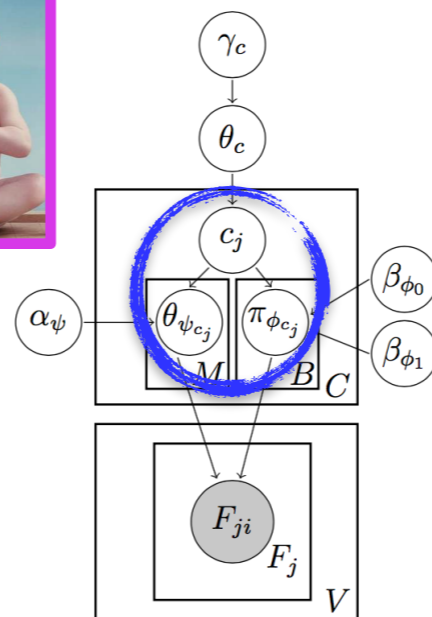
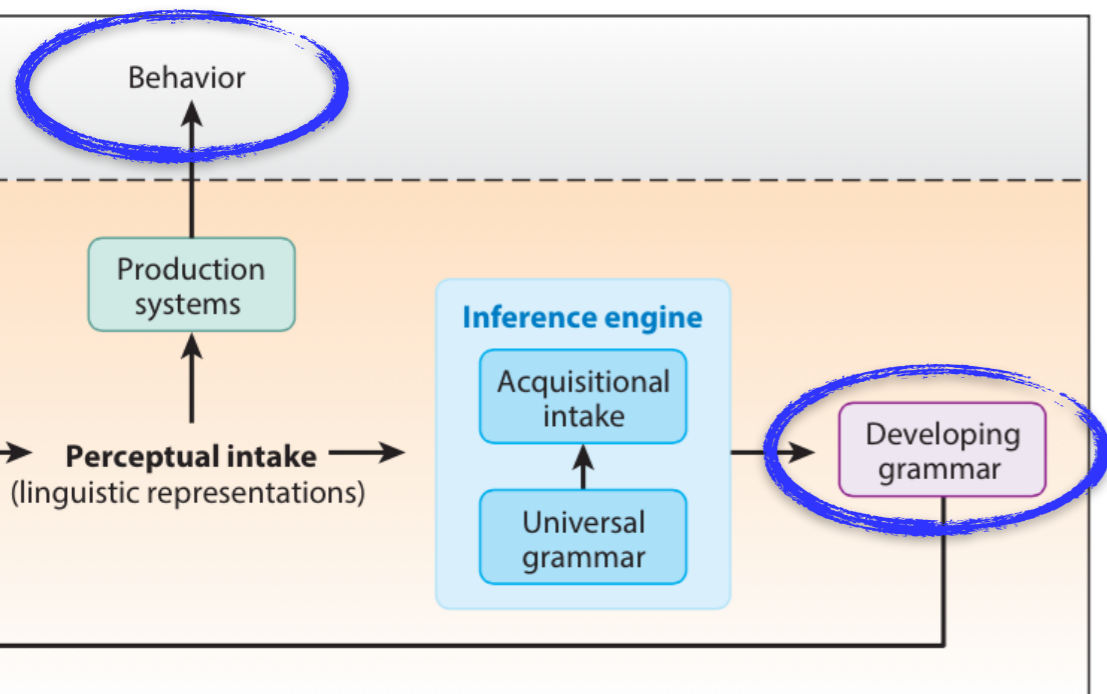

Goal: Model the developmental trajectory from 3 to 4 to 5 years old

<3yrs <4yrs <5yrs



verb classes

Survey of 32 experimental studies on children's production and comprehension of specific verbs



Subject-experienter and Object-experienter psych verbs: Hartshorne et al. 2015

Subject-experienter

“Jack ___ Lily.”
Experienter

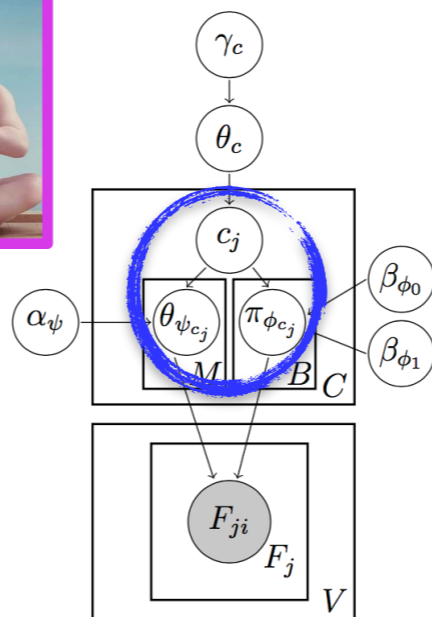
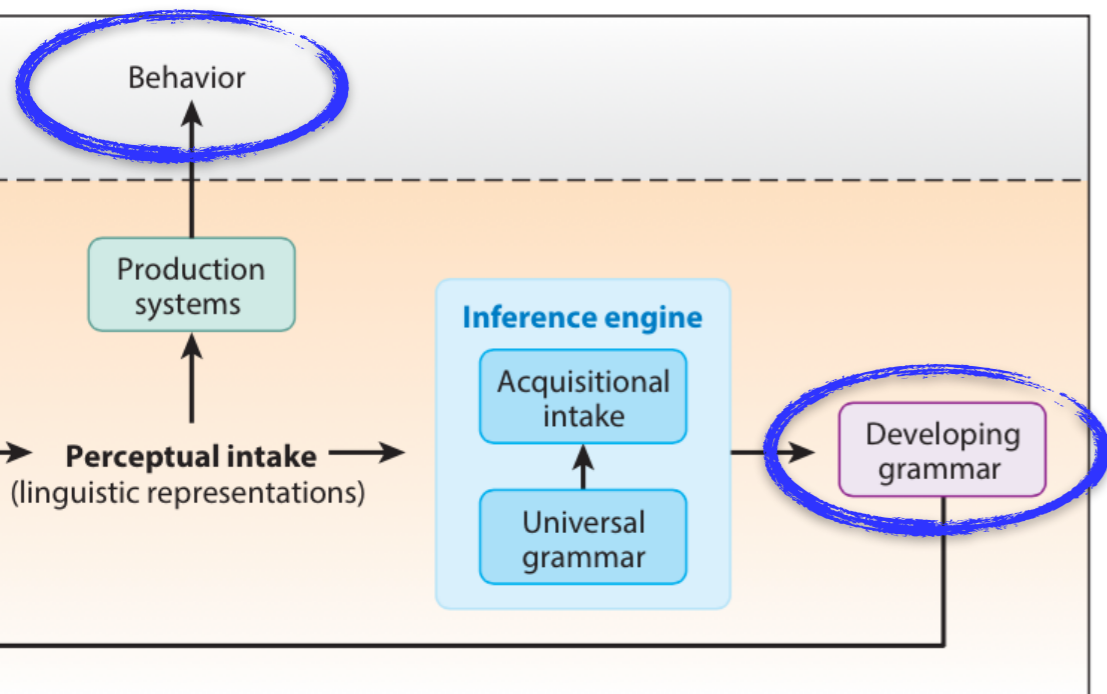

Goal: Model the developmental trajectory from 3 to 4 to 5 years old <math><3\text{yrs}</math>



verb classes

Survey of 32 experimental studies on children's production and comprehension of specific verbs



Subject-experienter and Object-experienter psych verbs: Hartshorne et al. 2015

Subject-experienter

"Jack ___ Lily."
Experienter

4yrs

5yrs

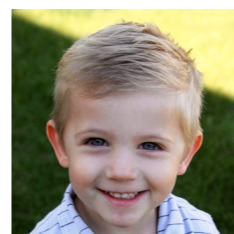

+ = like, love

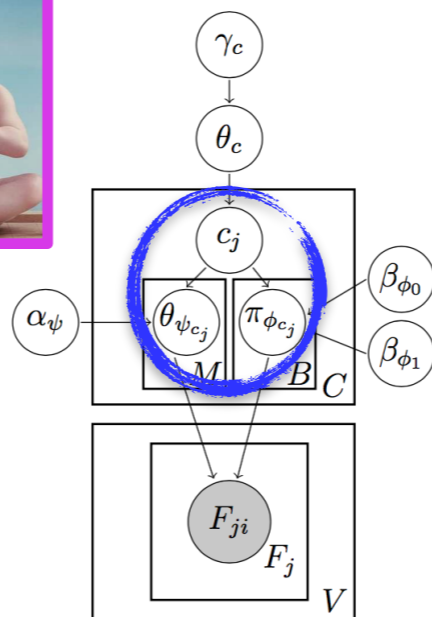
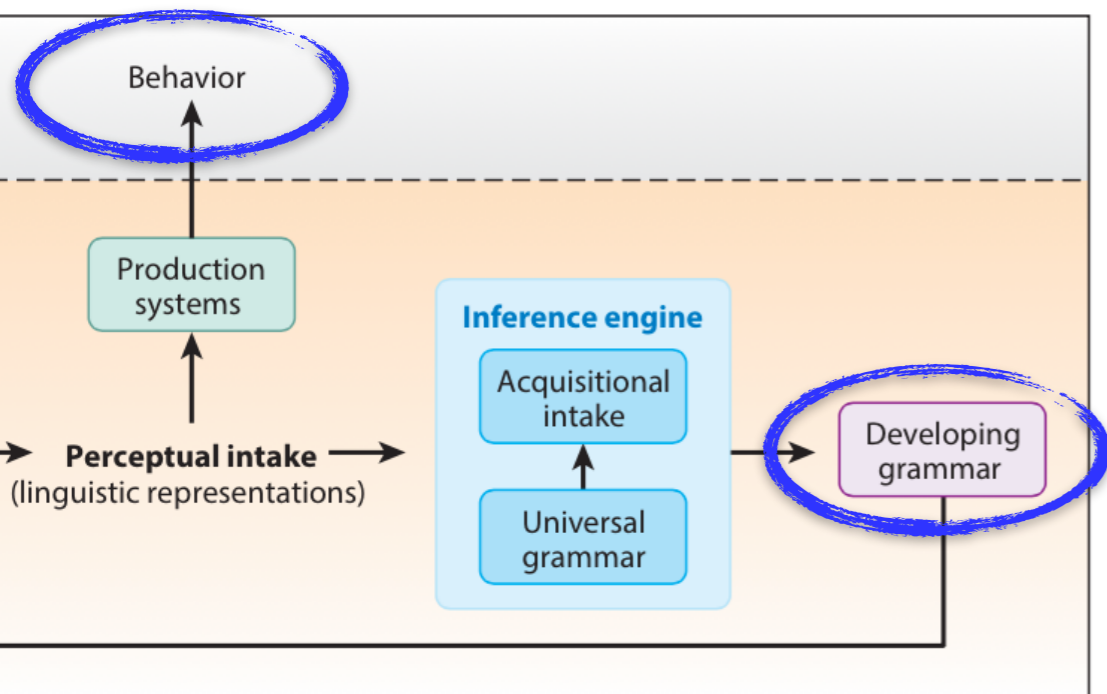

Goal: Model the developmental trajectory from 3 to 4 to 5 years old <3yrs



verb classes

Survey of 32 experimental studies on children's production and comprehension of specific verbs



Subject-experiencer and Object-experiencer psych verbs: Hartshorne et al. 2015

Object-experiencer

"Jack _____ Lily."
Experiencer

4yrs

5yrs

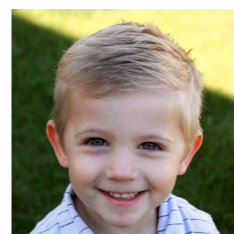

+ = frighten, scare, surprise

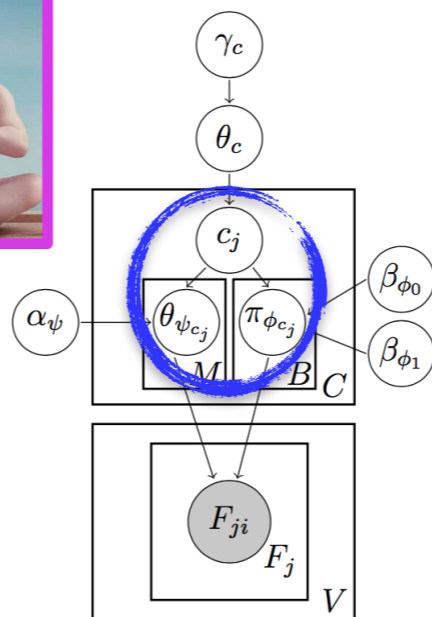
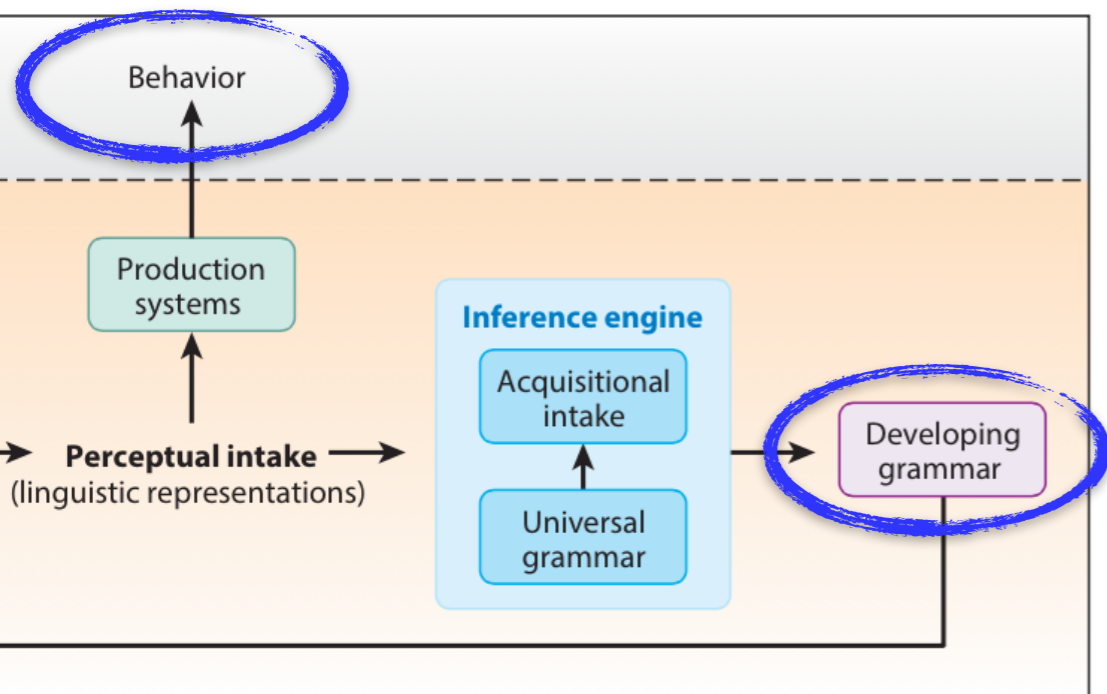

Goal: Model the developmental trajectory from 3 to 4 to 5 years old

<3yrs <4yrs <5yrs



verb classes

Survey of 32 experimental studies on children's production and comprehension of specific verbs



Complement-taking verbs [non-finite *to*, *that*, *whether/if*]: Bloom et al. 1984, Bloom et al. 1989, Diessel & Tomasello 2001, Papafragou et al. 2007, Kidd et al, 2006, Kidd et al. 2010

Non-finite *to*
"Jack ___ to go."

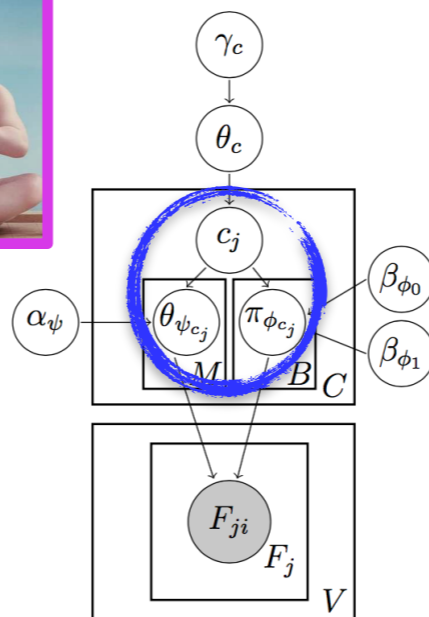
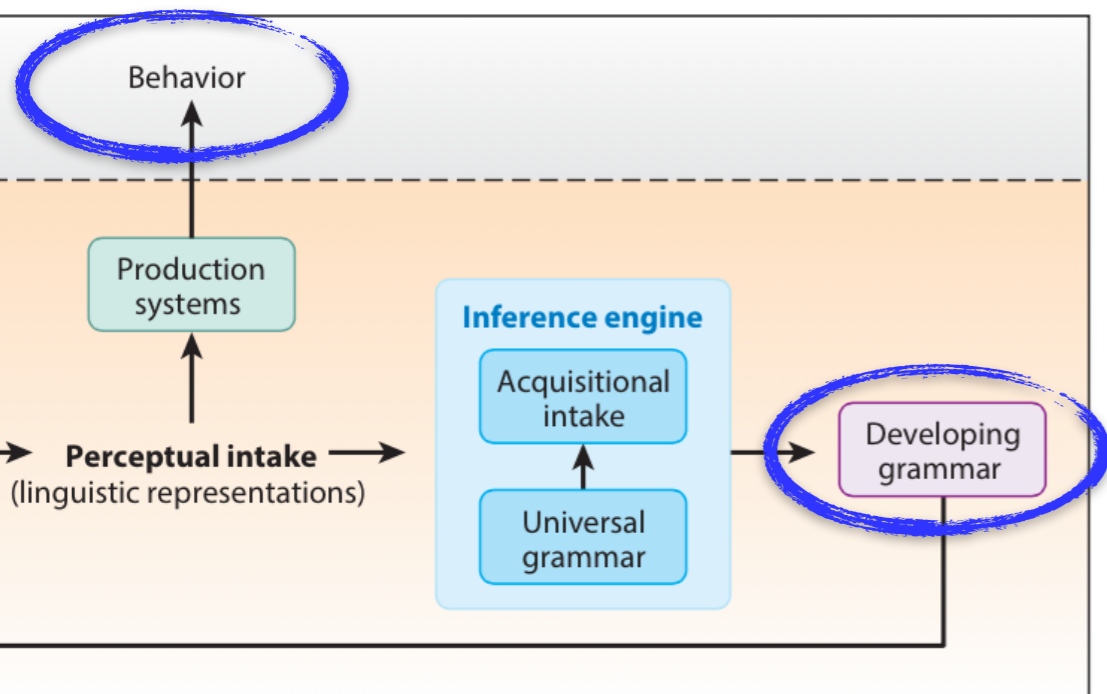

Goal: Model the developmental trajectory from 3 to 4 to 5 years old

<4yrs

<5yrs

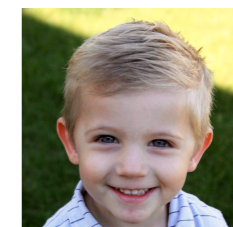

verb classes

Survey of **32** experimental studies on children's production and comprehension of specific verbs



Complement-taking verbs [non-finite *to*, *that*, *whether/if*]: Bloom et al. 1984, Bloom et al. 1989, Diessel & Tomasello 2001, Papafragou et al. 2007, Kidd et al, 2006, Kidd et al. 2010

Non-finite to

"Jack ___ to go."

3yrs



+ = get, start, suppose, ...

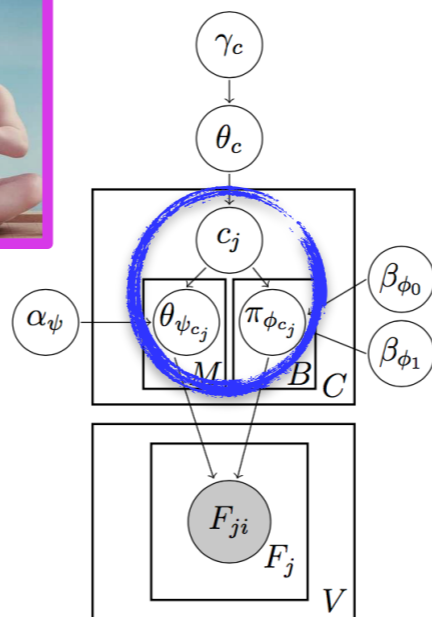
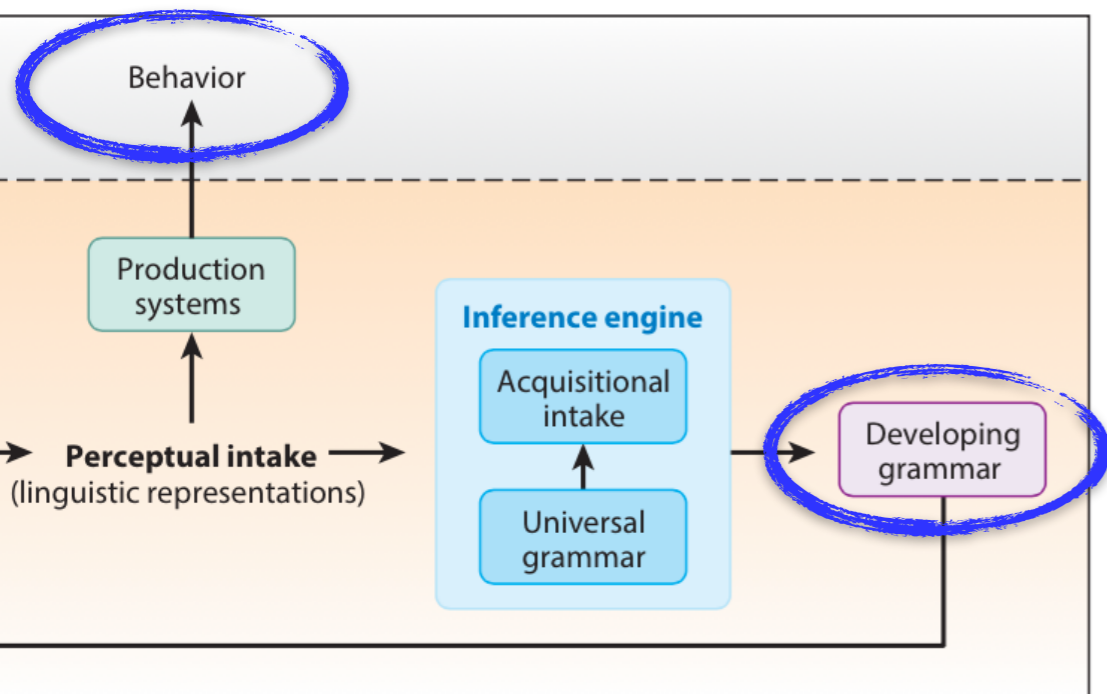

Goal: Model the developmental trajectory from 3 to 4 to 5 years old

<3yrs

<4yrs

<5yrs



verb classes

Survey of 32 experimental studies on children's production and comprehension of specific verbs



Complement-taking verbs [non-finite *to*, *that*, *whether/if*]: Bloom et al. 1984, Bloom et al. 1989, Diessel & Tomasello 2001, Papafragou et al. 2007, Kidd et al, 2006, Kidd et al. 2010

that

"Jack ___ that he can go."

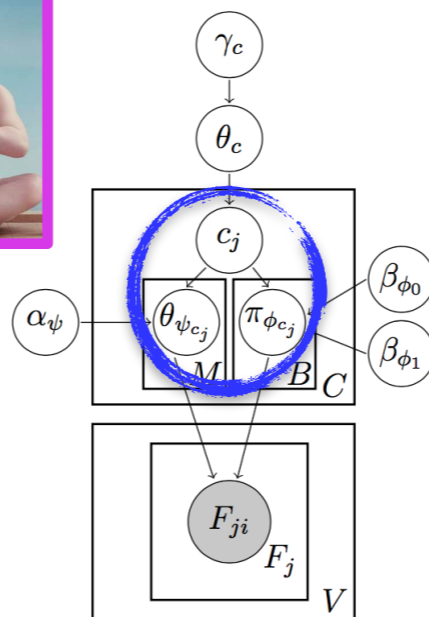
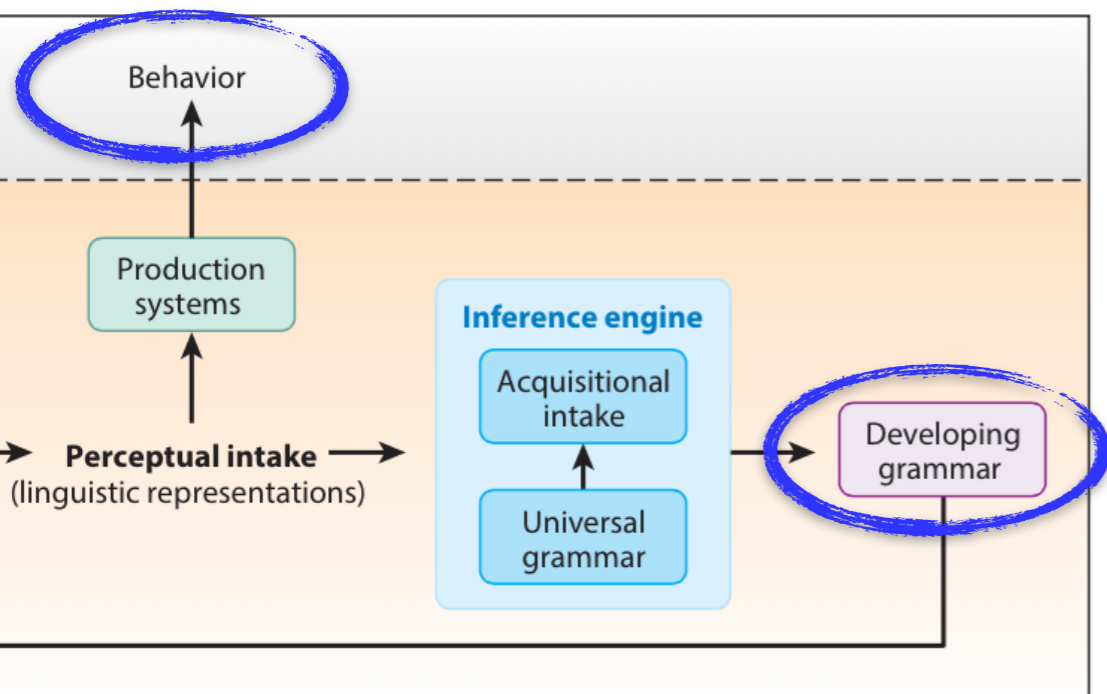

Goal: Model the developmental trajectory from 3 to 4 to 5 years old

<4yrs

<5yrs

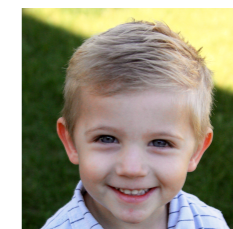

verb classes

Survey of **32** experimental studies on children's production and comprehension of specific verbs



Complement-taking verbs [non-finite *to*, *that*, *whether/if*]: Bloom et al. 1984, Bloom et al. 1989, Diessel & Tomasello 2001, Papafragou et al. 2007, Kidd et al, 2006, Kidd et al. 2010

that

“Jack ___ that he can go.”

3yrs



+= hope, know, say, ...

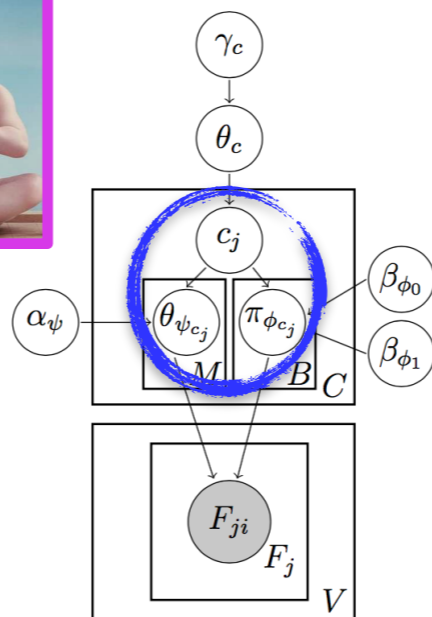
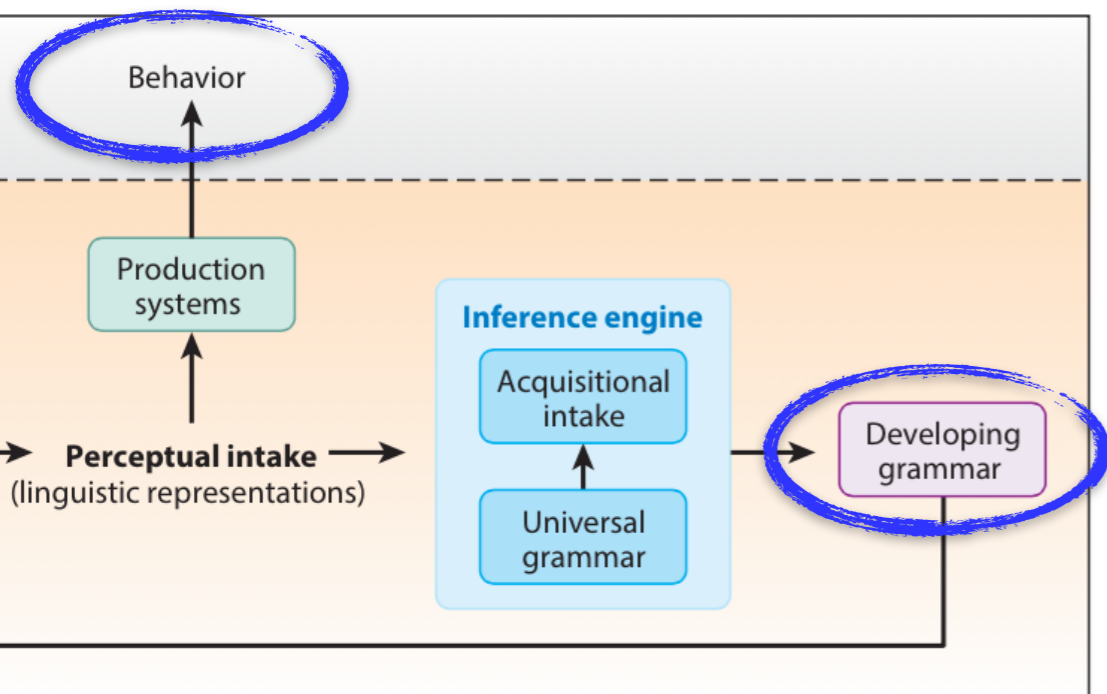

Goal: Model the developmental trajectory from 3 to 4 to 5 years old

<3yrs

<4yrs



verb classes

Survey of 32 experimental studies on children's production and comprehension of specific verbs



Complement-taking verbs [non-finite *to*, *that*, *whether/if*]: Bloom et al. 1984, Bloom et al. 1989, Diessel & Tomasello 2001, Papafragou et al. 2007, Kidd et al, 2006, Kidd et al. 2010

that

"Jack ___ that he can go."

5yrs



+ = guess, hope, know, pretend, say, ...

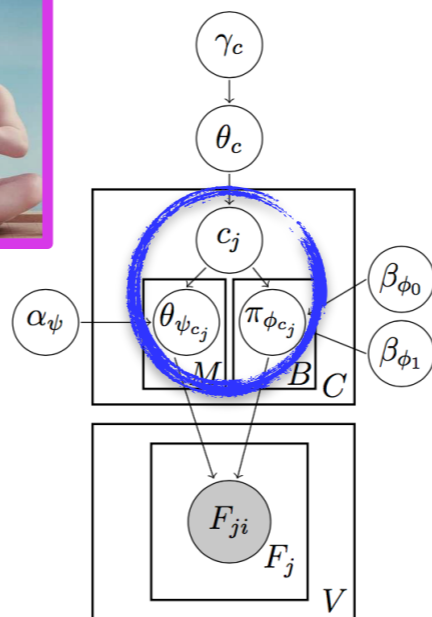
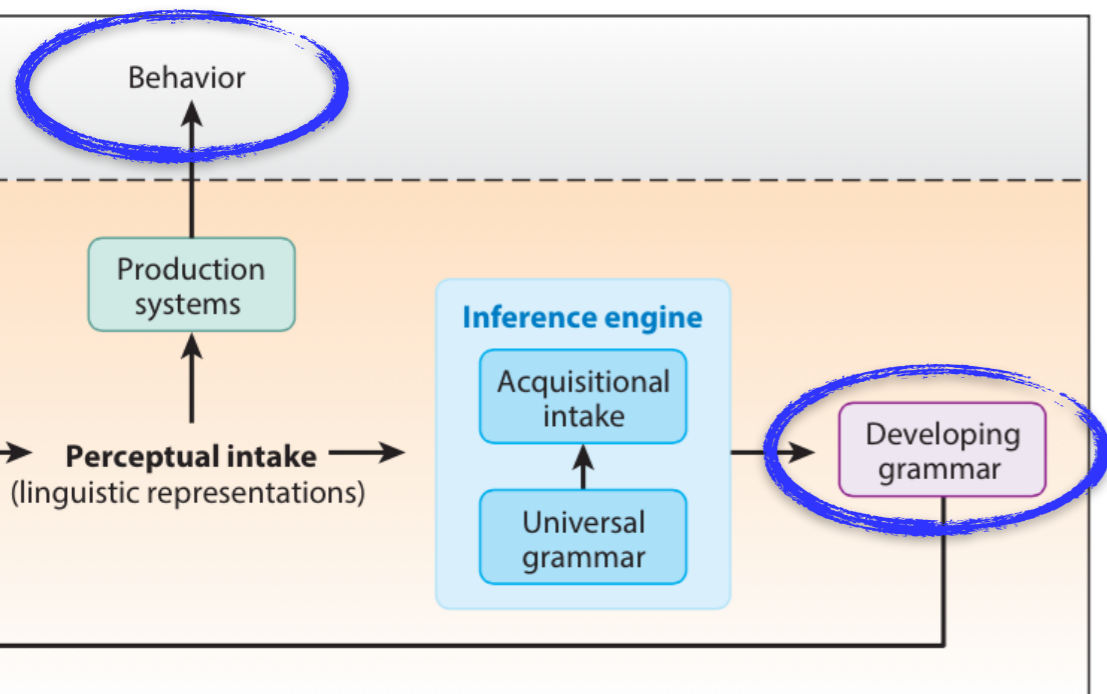

Goal: Model the developmental trajectory from 3 to 4 to 5 years old

<3yrs <4yrs <5yrs



verb classes

Survey of 32 experimental studies on children's production and comprehension of specific verbs



Complement-taking verbs [non-finite *to*, *that*, *whether/if*]: Bloom et al. 1984, Bloom et al. 1989, Diessel & Tomasello 2001, Papafragou et al. 2007, Kidd et al, 2006, Kidd et al. 2010

whether/if

"Jack ___ *whether/if* he can go."

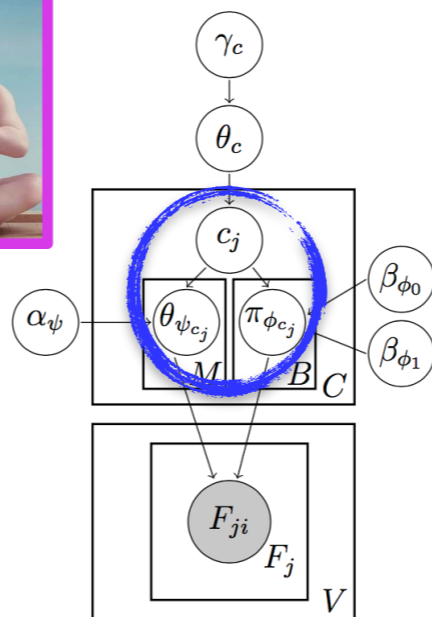
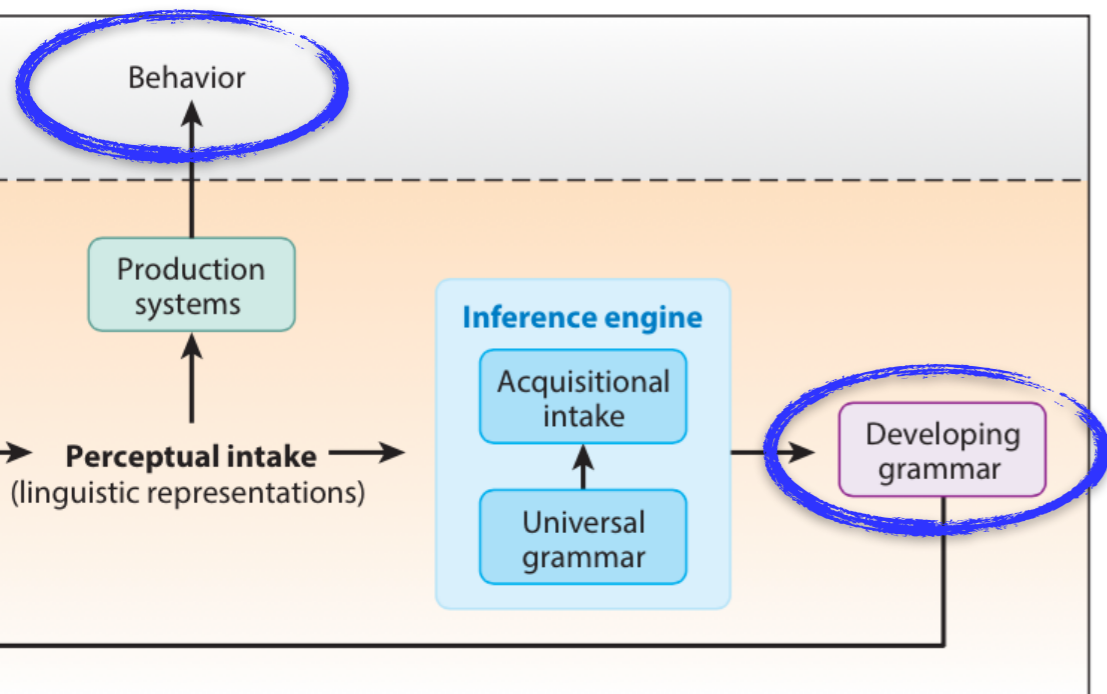

Goal: Model the developmental trajectory from 3 to 4 to 5 years old

<3yrs

<4yrs



verb classes

Survey of 32 experimental studies on children's production and comprehension of specific verbs



Complement-taking verbs [non-finite *to*, *that*, *whether/if*]: Bloom et al. 1984, Bloom et al. 1989, Diessel & Tomasello 2001, Papafragou et al. 2007, Kidd et al, 2006, Kidd et al. 2010

whether/if

"Jack ___ *whether/if* he can go."

5yrs



+ = ask, care, know, see, ...

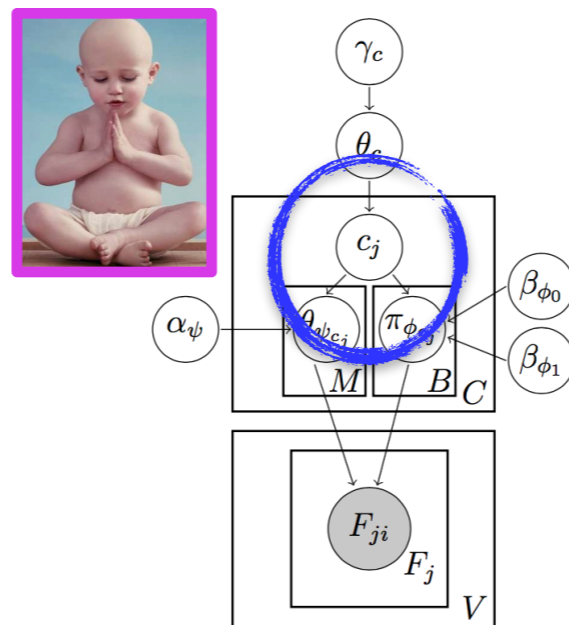
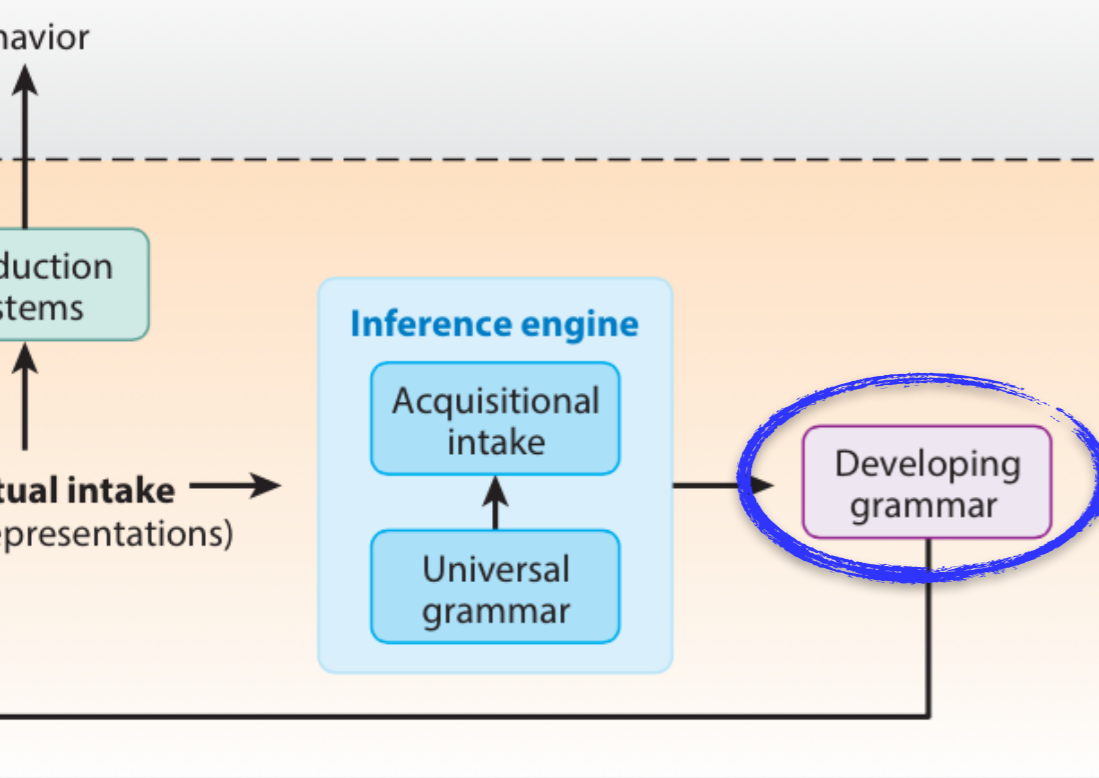

1% ≤ RI ≤ 99% CI

-1.0 ≤ ARI ≤ 1.0

Goal: Model the developmental trajectory from 3 to 4 to 5 years old

<3yrs

<4yrs

<5yrs

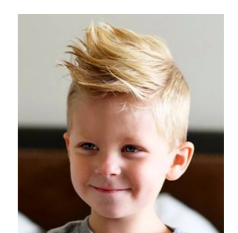

15 classes

23 classes

24 classes

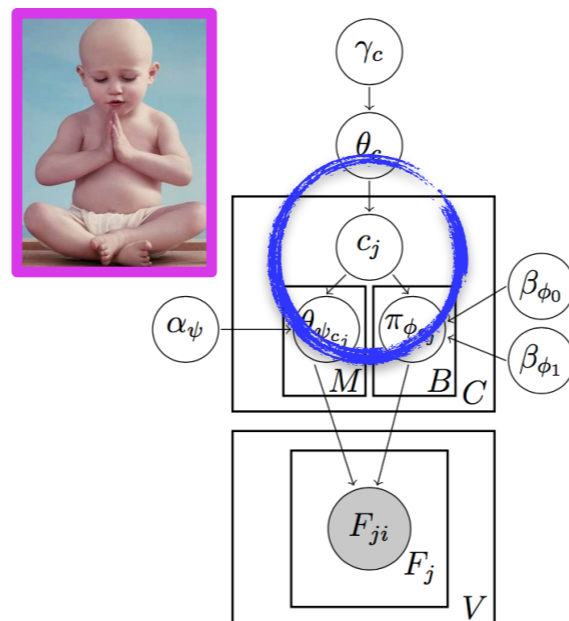
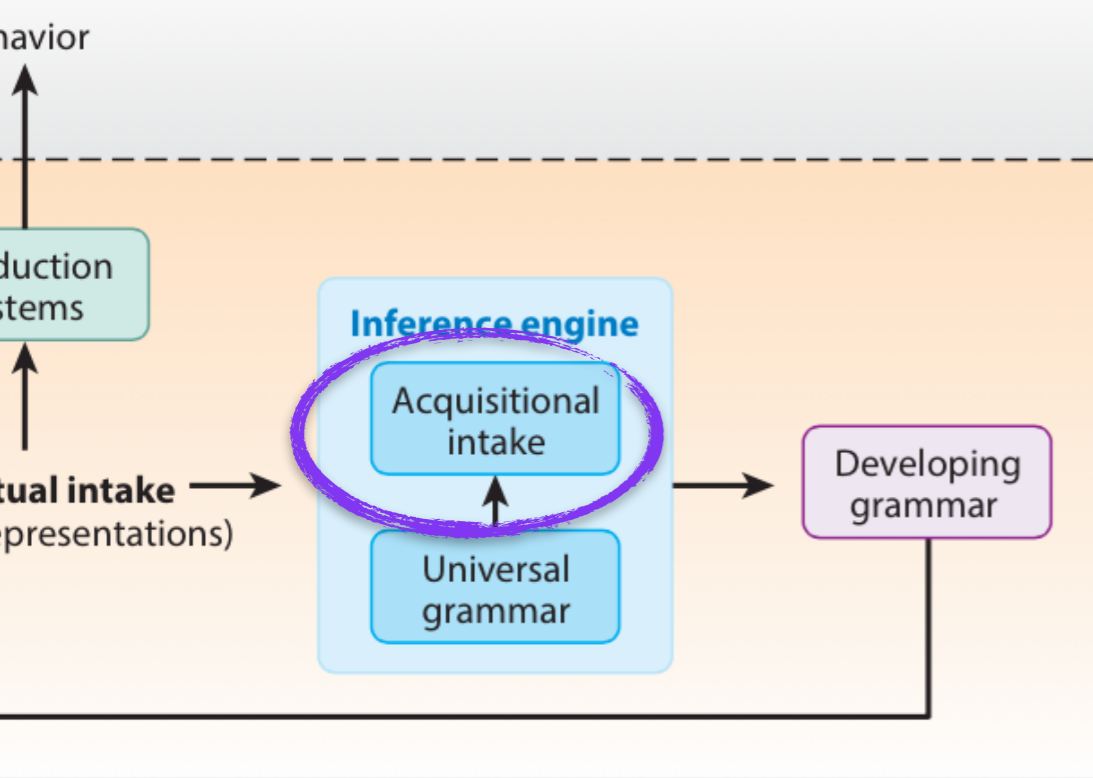

1% \leq RI \leq 99% CI
 -1.0 \leq ARI \leq 1.0

Goal: Model the developmental trajectory from 3 to 4 to 5 years old

<3yrs	<4yrs	<5yrs
		
15 classes	23 classes	24 classes

Animacy

+animate
 The penguin tried to climb.



-animate
 The ice seemed to melt.



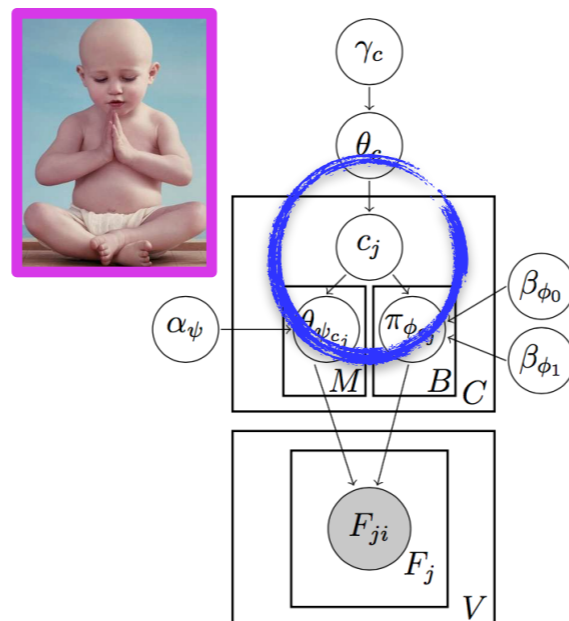
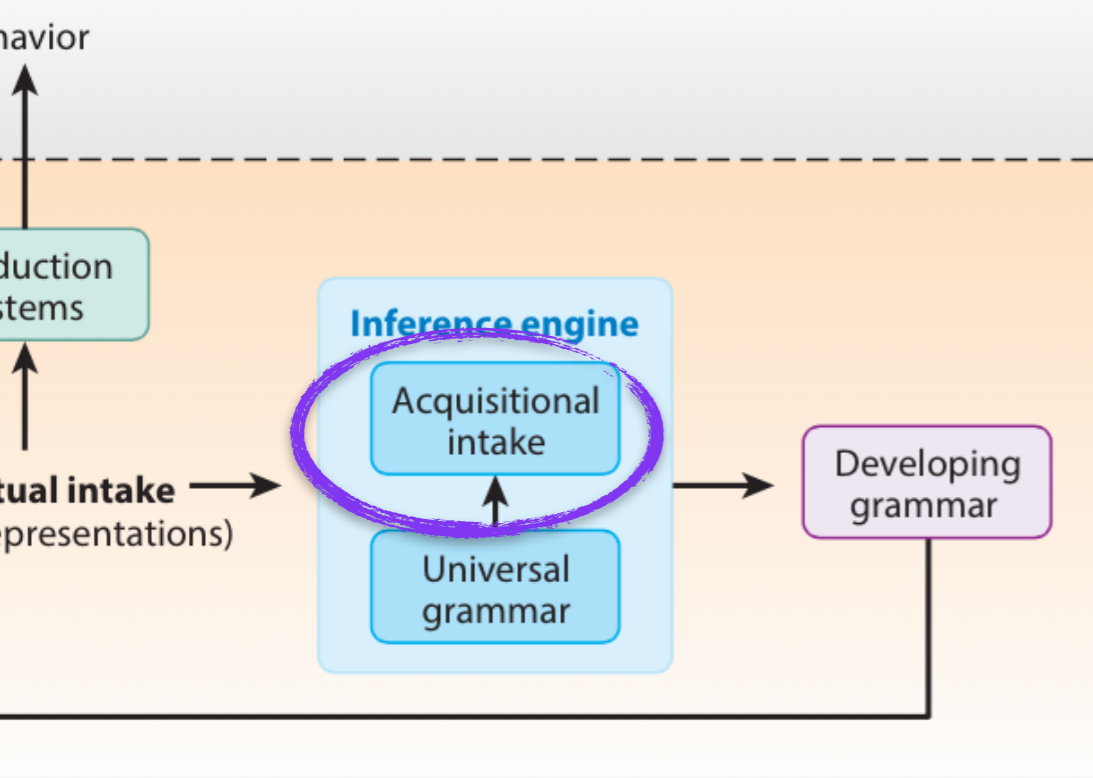

Goal: Model the developmental trajectory from 3 to 4 to 5 years old

<3yrs **<4yrs** **<5yrs**

15 classes **23 classes** **24 classes**

☹️ 😐 😊

1% ≤ RI ≤ 99% CI

-1.0 ≤ ARI ≤ 1.0



Animacy

Syntactic frame

The ice seemed to melt.

NP _____ S_{nonfinite} -surfmorph

NP _____+past S_{nonfinite} +surfmorph

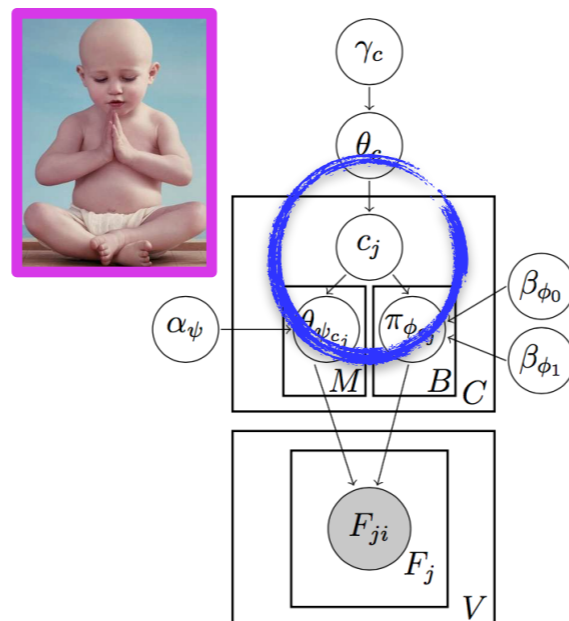
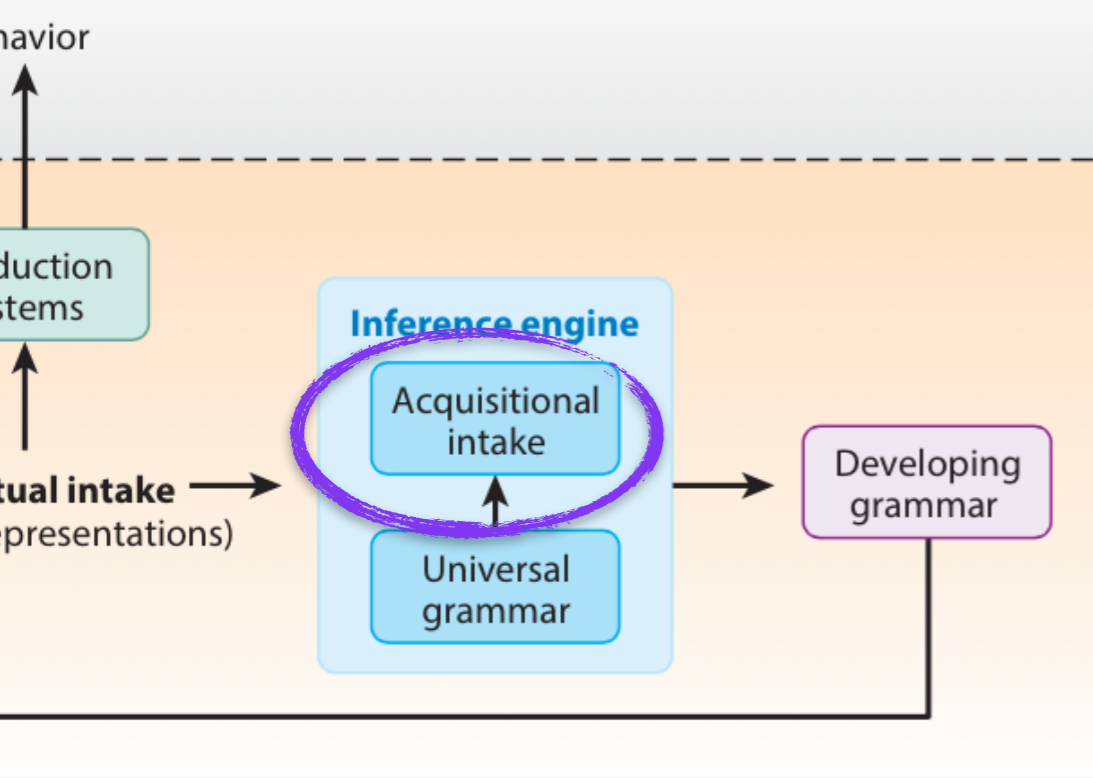

1% <= RI <= 99% CI
-1.0 <= ARI <= 1.0

Goal: Model the developmental trajectory from 3 to 4 to 5 years old

<3yrs <4yrs <5yrs

15 classes 23 classes 24 classes

Animacy

+surfmorph

Syntactic frame

-surfmorph

Thematic roles and how to use them



Agent > Experiencer >
Theme > Patient >
(Source, Goal, Instrument)

UTAH

rUTAH

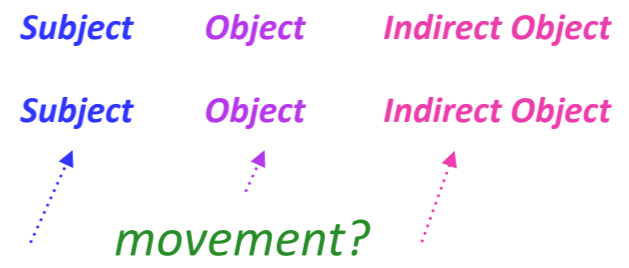

-expmap

+expmap

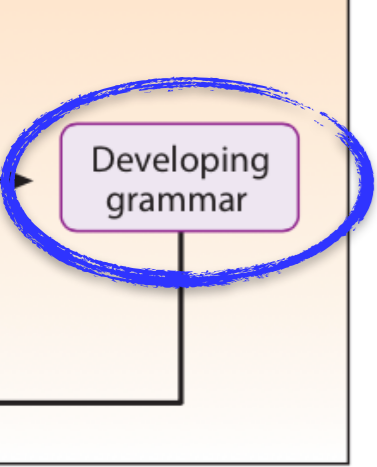



Animacy
Syntactic frame



 1% <= RI <= 99% CI
 -1.0 <= ARI <= 1.0

<4yrs



23 classes

<5yrs



24 classes

+surfmorph

-surfmorph

Thematic roles and how to use them

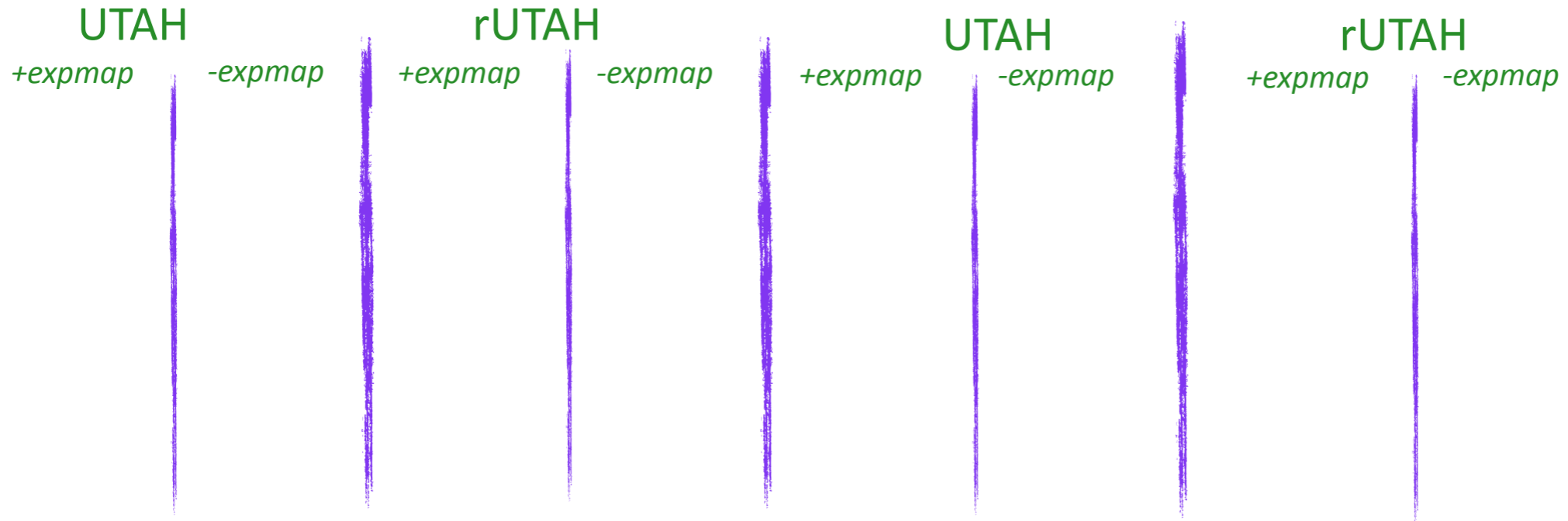



3yrs

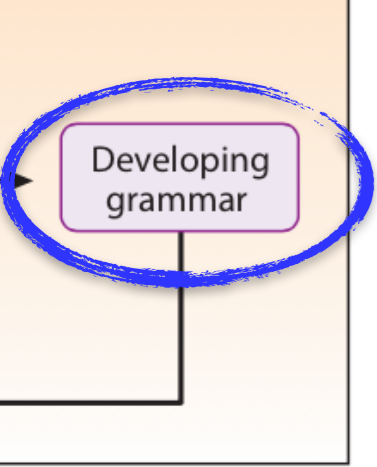

15 classes



Animacy
Syntactic frame



 $1\% \leq RI \leq 99\% CI$
 $-1.0 \leq ARI \leq 1.0$

<4yrs



23 classes

<5yrs



24 classes

+surfmorph

-surfmorph

Thematic roles and how to use them

UTAH

rUTAH

UTAH

rUTAH

+expmap

-expmap

+expmap

-expmap

+expmap

-expmap

+expmap

-expmap



3yrs
15 classes

RI

0.567

0.650

0.544

0.615

0.673

0.698

0.766

0.749

ARI

0.053

0.063

0.050

0.144

0.213

0.238



0.221

0.193

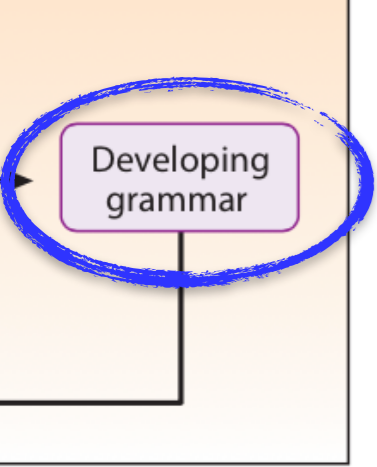
Two learning strategies are doing significantly better than chance based on both metrics.



Animacy
Syntactic frame



 1% <= RI <= 99% CI
 -1.0 <= ARI <= 1.0

<5yrs



24 classes

+surfmorph

-surfmorph

Thematic roles and how to use them

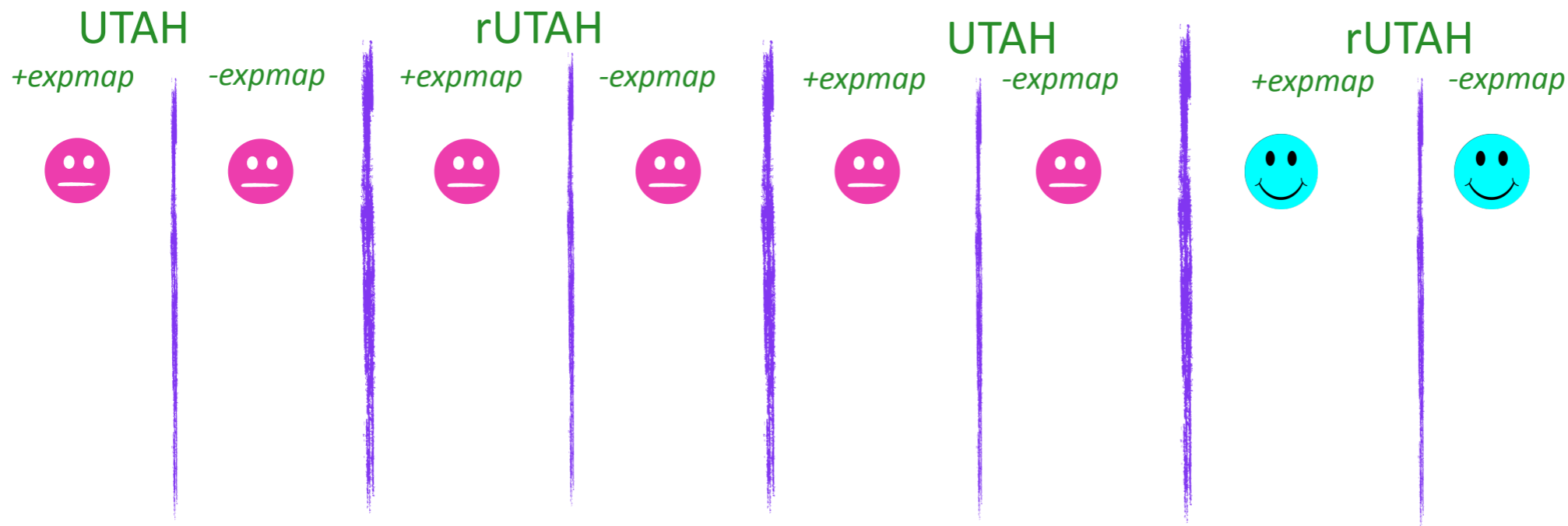

3yrs
15 classes



<4yrs

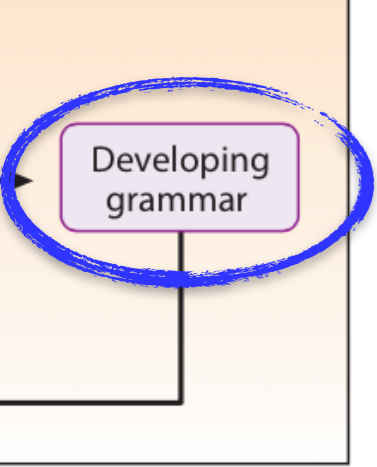

23 classes



Animacy
Syntactic frame



 1% <= RI <= 99% CI
 -1.0 <= ARI <= 1.0

<5yrs



24 classes

+surfmorph

-surfmorph

Thematic roles and how to use them

UTAH

rUTAH

UTAH

rUTAH

+expmap

-expmap

+expmap

-expmap

+expmap

-expmap

+expmap

-expmap



3yrs

15 classes

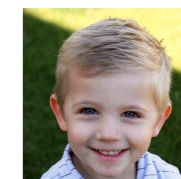

4yrs

23 classes

RI

0.639

0.758

0.670

0.504

0.773

0.756

0.716

0.743

ARI

0.143

0.261

0.080

0.103

0.102

0.091



0.090

0.120

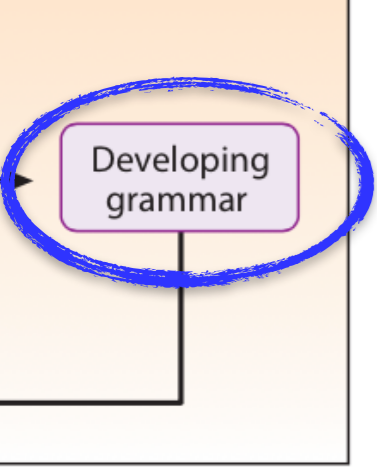
One strategy (a different one) is doing significantly better than chance.



Animacy
Syntactic frame



 1% <= RI <= 99% CI
 -1.0 <= ARI <= 1.0

+surfmorph

-surfmorph

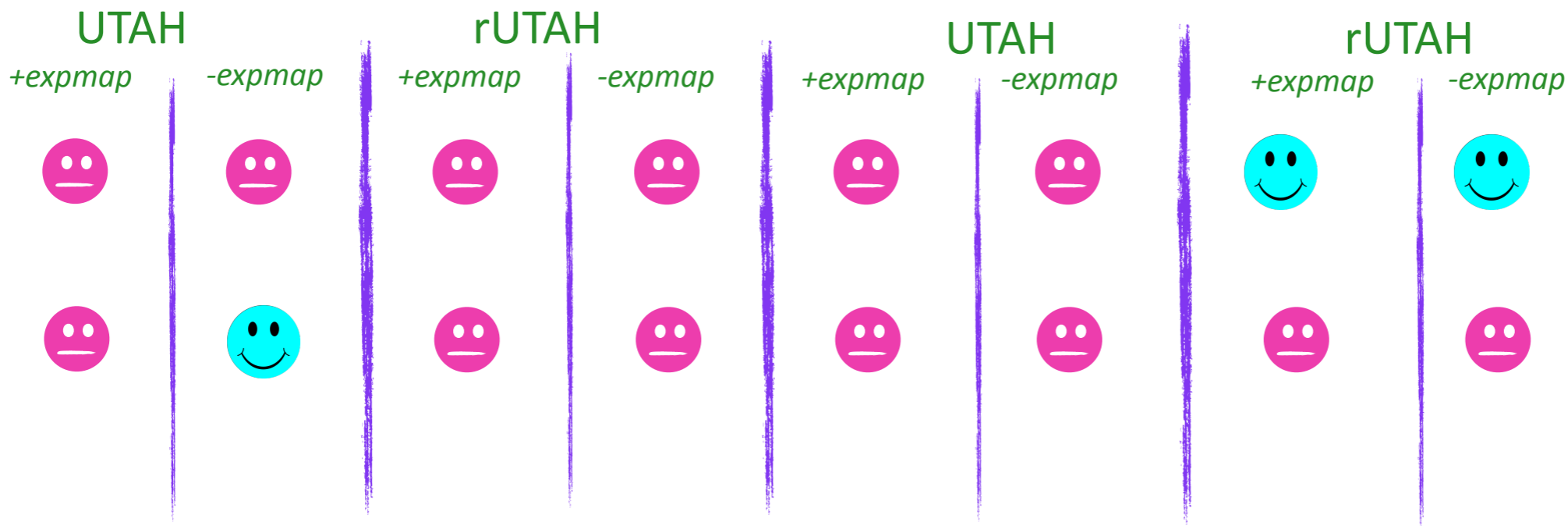
Thematic roles and how to use them



3yrs
15 classes







4yrs
23 classes

<5yrs

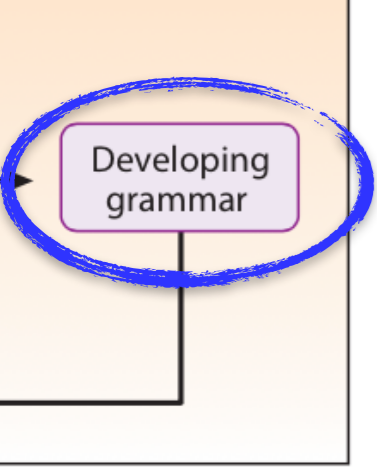

24 classes





























 1% <= RI <= 99% CI
 -1.0 <= ARI <= 1.0

Animacy
Syntactic frame

+surfmorph

-surfmorph



Thematic roles and how to use them

	UTAH		rUTAH		UTAH		rUTAH	
	+expmap	-expmap	+expmap	-expmap	+expmap	-expmap	+expmap	-expmap
								
								
								
RI	0.751	0.703	0.754	0.682	0.803	0.758	0.765	0.781
ARI	0.256	0.087	0.279	0.096	0.120	0.114	0.113	0.149

 **3yrs**
 15 classes
 **4yrs**
 23 classes
 **5yrs**
 24 classes

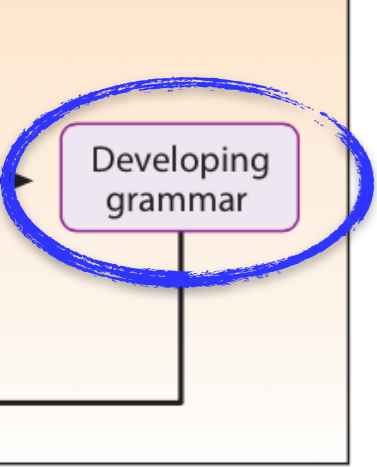
Several learning strategies are doing better than chance...





























 1% <= RI <= 99% CI
 -1.0 <= ARI <= 1.0

Animacy
Syntactic frame

+surfmorph

-surfmorph

Thematic roles and how to use them

	UTAH		rUTAH		UTAH		rUTAH	
	+expmap	-expmap	+expmap	-expmap	+expmap	-expmap	+expmap	-expmap
								
								
								
RI	0.751	0.703	0.754	0.682	0.803	0.758	0.765	0.781
ARI	0.256	0.087	0.279	0.096	0.120	0.114	0.113	0.149

 **3yrs**
 15 classes
 **4yrs**
 23 classes
 **5yrs**
 24 classes

...but two have ARIs that seem much higher than the rest, and on par with the ARIs of previous strategies with significantly higher performance (ARI > 0.20).

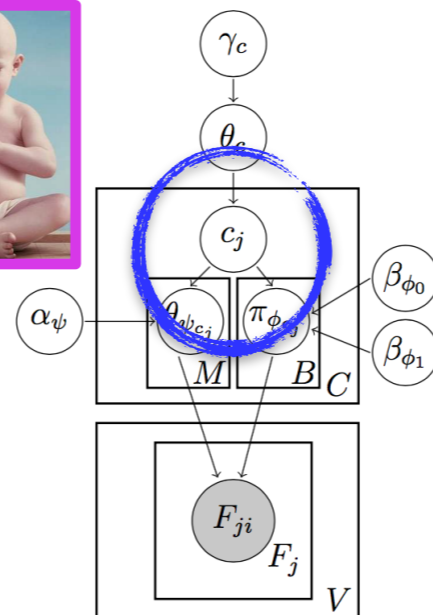
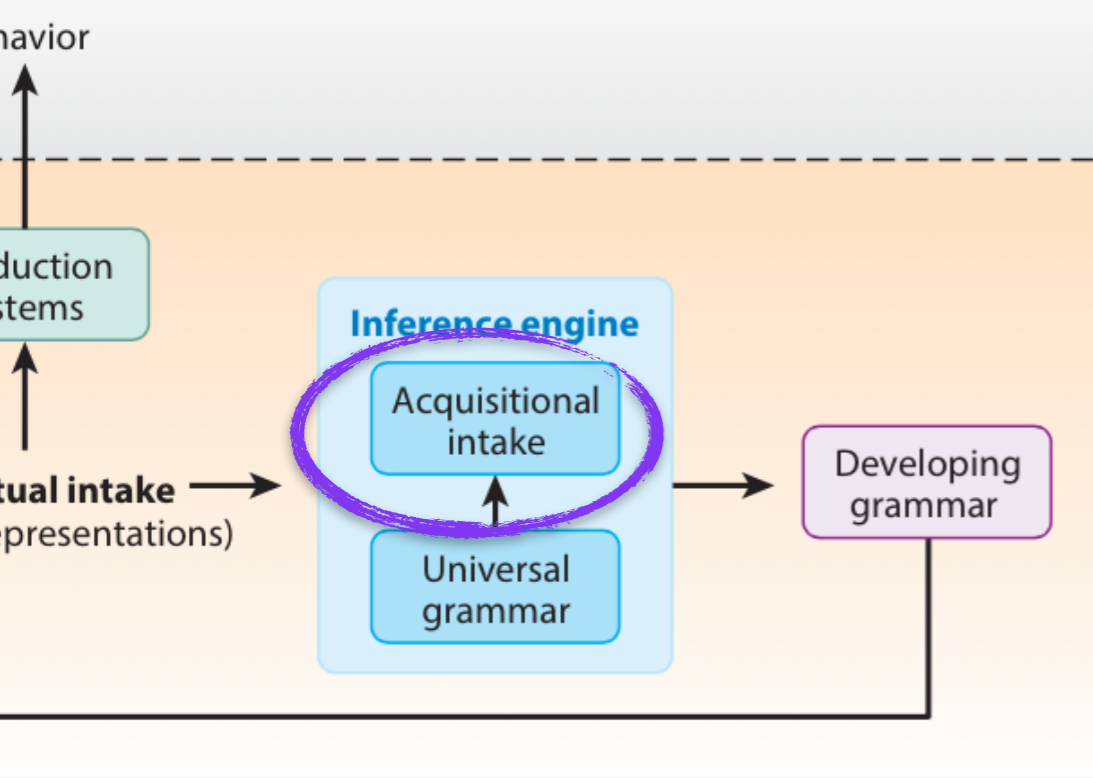

1% \leq RI \leq 99% CI

-1.0 \leq ARI \leq 1.0

Goal: Model the developmental trajectory from 3 to 4 to 5 years old

<3yrs

<4yrs

<5yrs



15 classes



23 classes



24 classes

Animacy

Syntactic frame

+surfmorph

-surfmorph

Thematic roles and how to use them

UTAH
+expmap | -expmap

rUTAH
+expmap | -expmap

UTAH
+expmap | -expmap

rUTAH
+expmap | -expmap

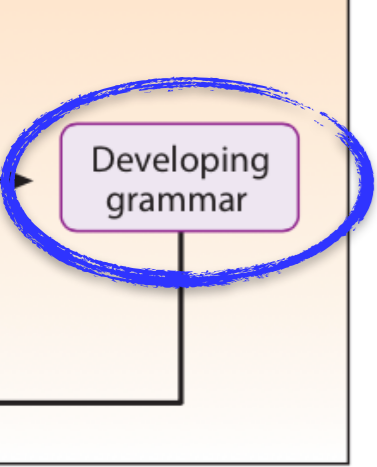

Animacy Syntactic frame

+surfmorph

-surfmorph

Thematic roles and how to use them

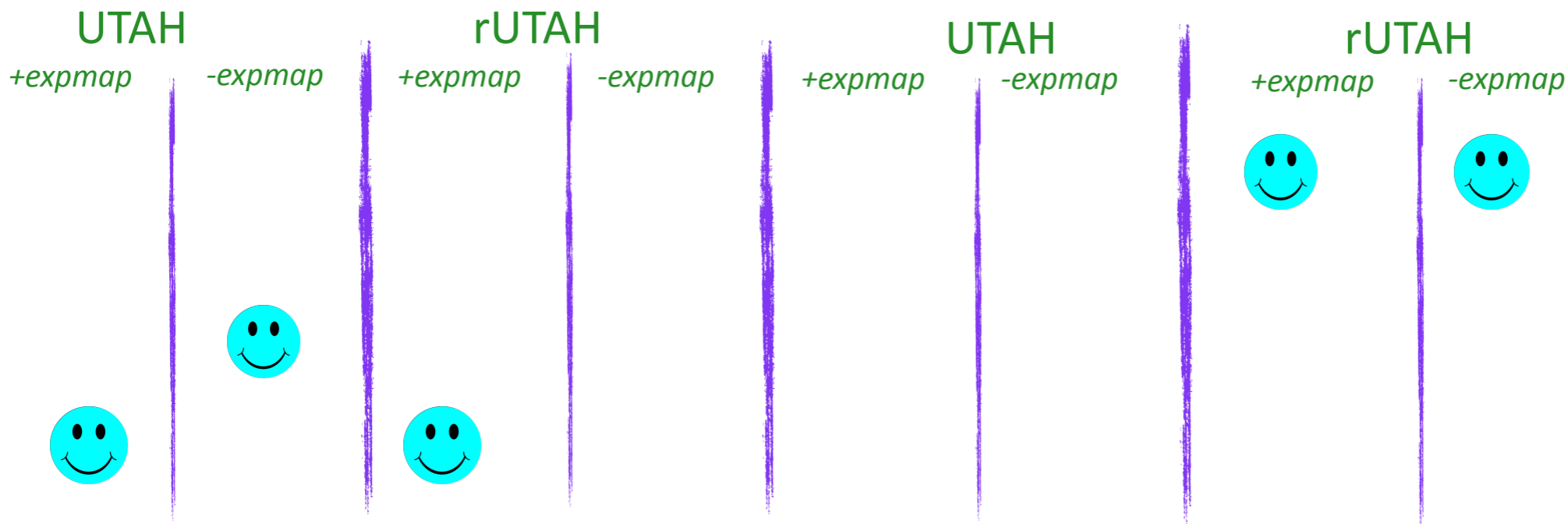

3yrs
15 classes



4yrs
23 classes



5yrs
24 classes

Focus on strategies with performance significantly above chance



What does this mean?

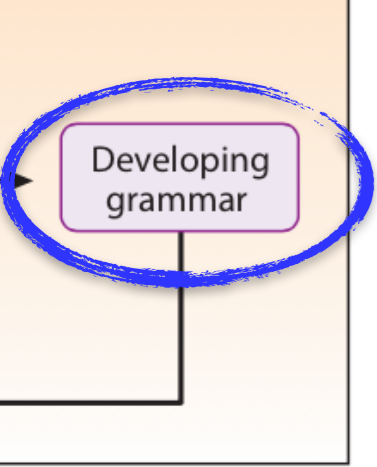

Animacy
Syntactic frame

+surfmorph

-surfmorph

Thematic roles and how to use them

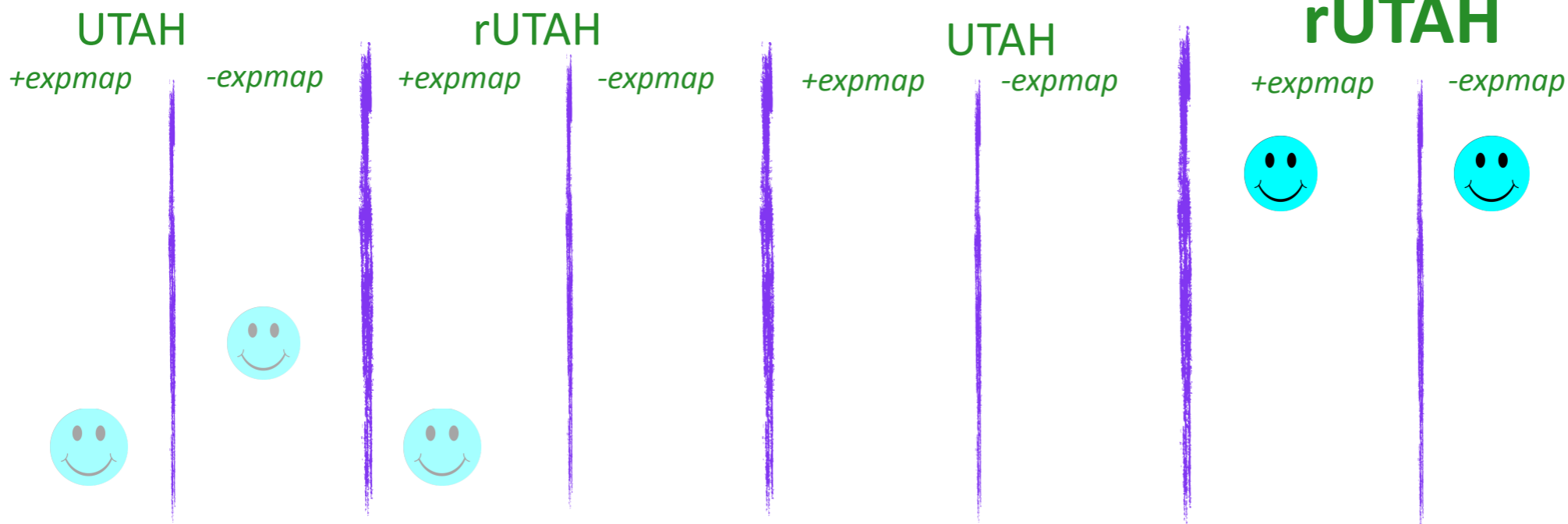

4yrs
23 classes

5yrs
24 classes



3yrs



Syntactic frame

The ice seemed to melt.
NP ____ S_{nonfinite} -surfmorph

rUTAH

Agent > Experiencer >
Theme > Patient >
(Source, Goal, Instrument)

Before 3, children ignore verb morphology and seem to be using relative information about thematic roles.

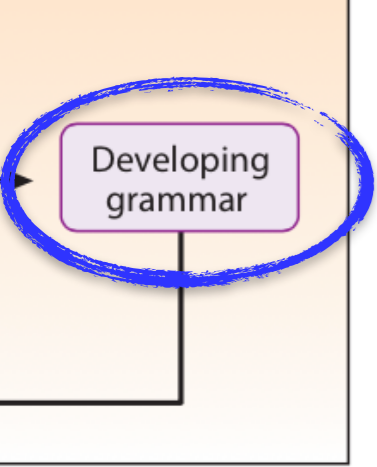

Animacy
Syntactic frame

+surfmorph

-surfmorph

Thematic roles and how to use them

UTAH

rUTAH

UTAH

rUTAH

+expmap

-expmap

+expmap

-expmap

+expmap

-expmap

+expmap

-expmap



3yrs



-surfmorph
rUTAH



4yrs

Syntactic frame

+surfmorph

NP ____ +past S_{nonfinite}

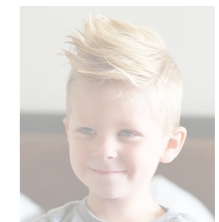

5yrs

24 classes

By 4, children heed verb morphology, are using the UTAH intermediate representation, and don't expect a mapping a priori.

Thematic roles
and how to use them

UTAH

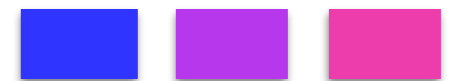

-expmap
Subject Object Indirect Object

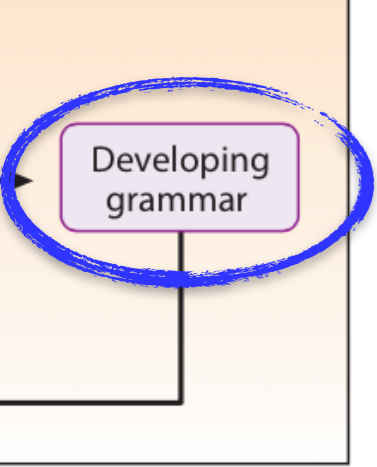

Animacy
Syntactic frame

+surfmorph

-surfmorph

Thematic roles and how to use them

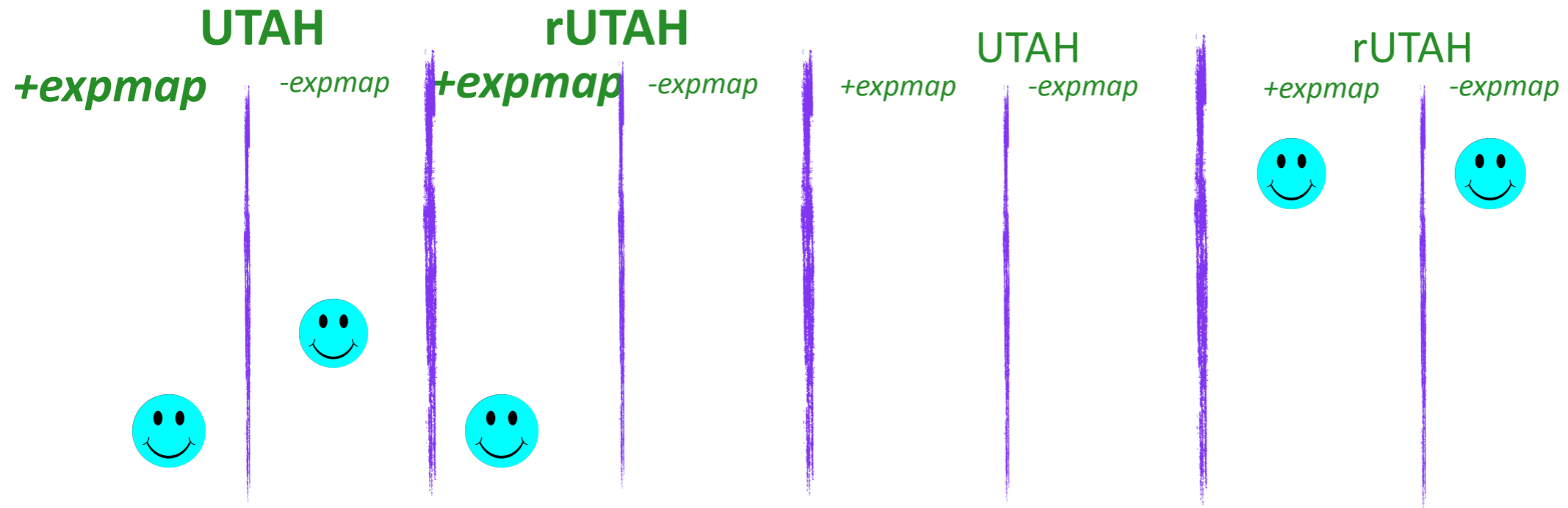

3yrs



-surfmorph
rUTAH

4yrs

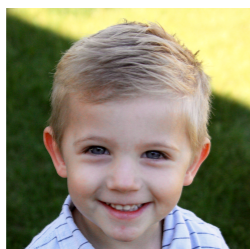

+surfmorph
UTAH
-expmap

5yrs



By 5, children still heed verb morphology, but now may be using either the UTAH or rUTAH representation and expect a mapping.

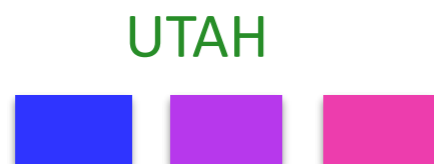

rUTAH Agent > Experiencer > +expmap
Theme > Patient >
(Source, Goal, Instrument)

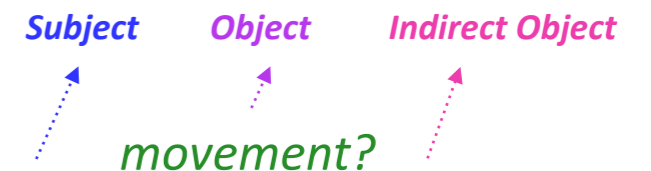

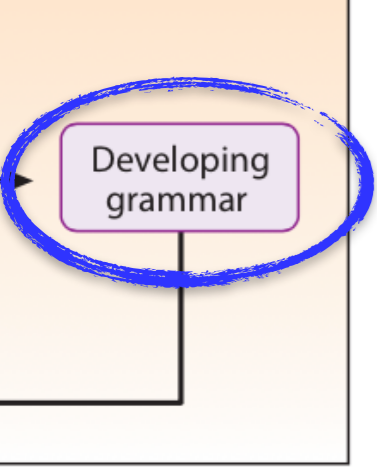

+surfmorph

-surfmorph

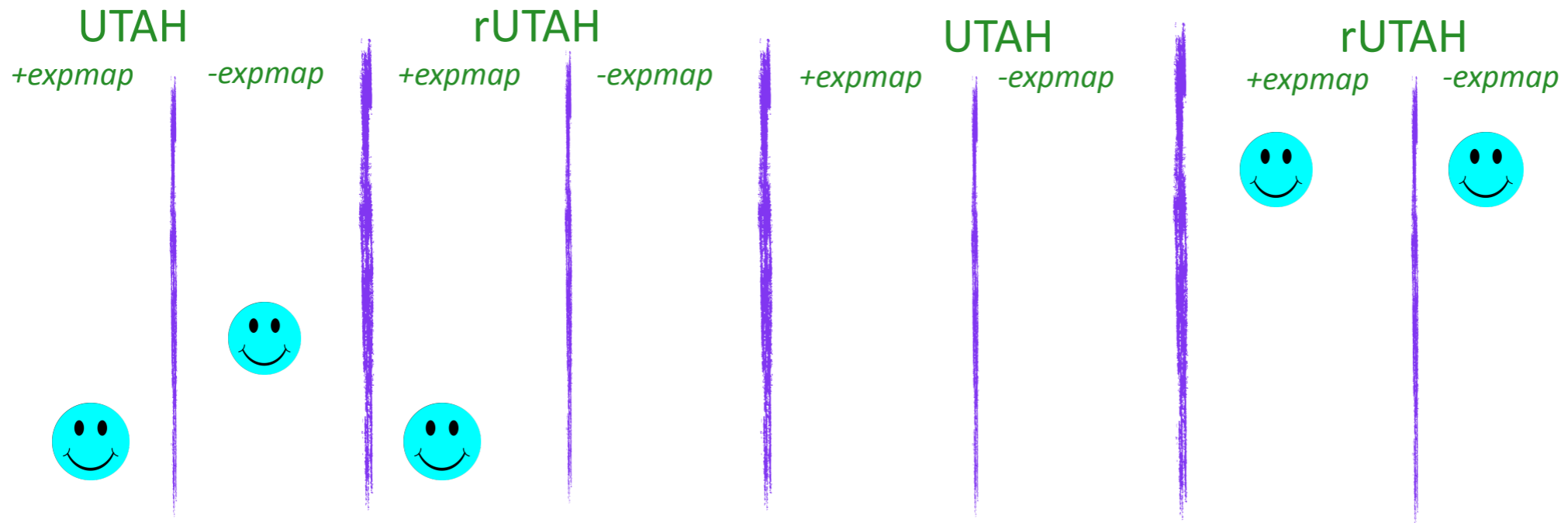

3yrs
15 classes



4yrs
23 classes



5yrs
24 classes

Animacy
Syntactic frame
Thematic roles and how to use them



Using animacy, syntactic frame, and thematic role information can be a pretty good match for what children seem to be doing when creating verb classes.

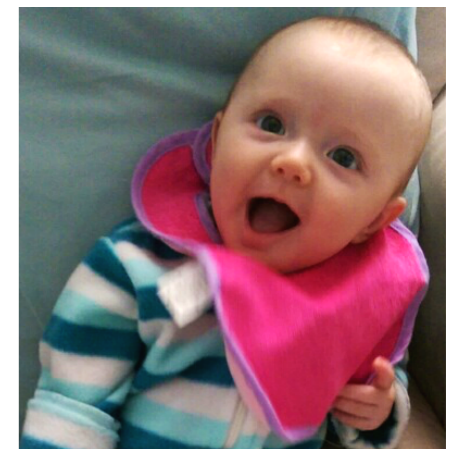

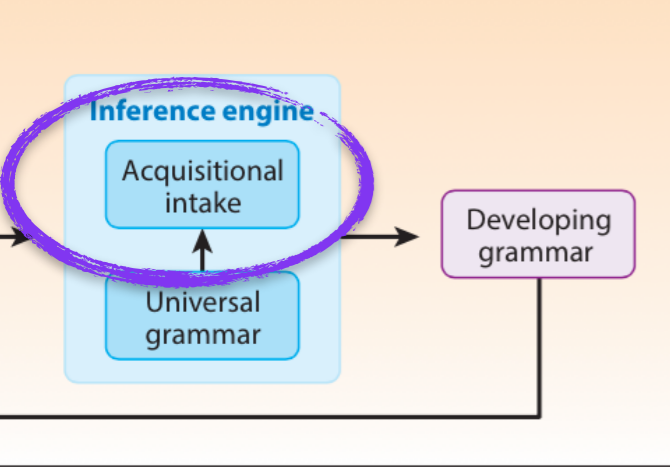

-animate
Subject
The ice seemed to melt.

NP _____ S_{nonfinite}
Highest

3yrs



-surfmorph
rUTAH

Agent > Experiencer >
Theme > Patient >
(Source, Goal, Instrument)

Subject Object Indirect Object

4yrs



+surfmorph
UTAH
-expmap

5yrs



+surfmorph
UTAH rUTAH
+expmap

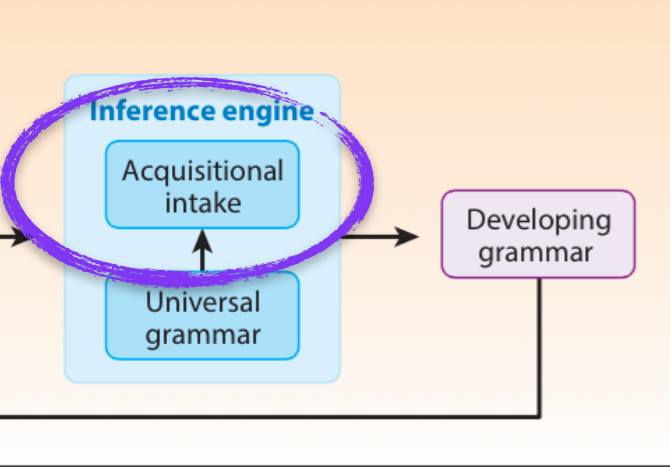

-animate
Subject
 The ice seemed to melt.

NP ____ +past Snonfinite

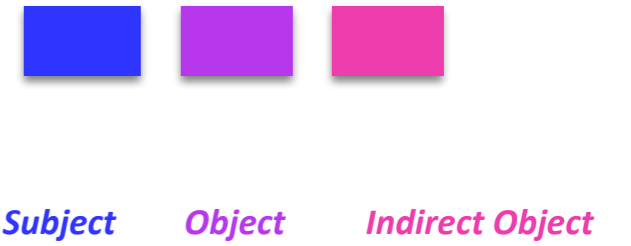

3yrs



-surfmorph
 rUTAH

4yrs



+surfmorph
 UTAH
 -expmap

5yrs



+surfmorph
 UTAH rUTAH
 +expmap

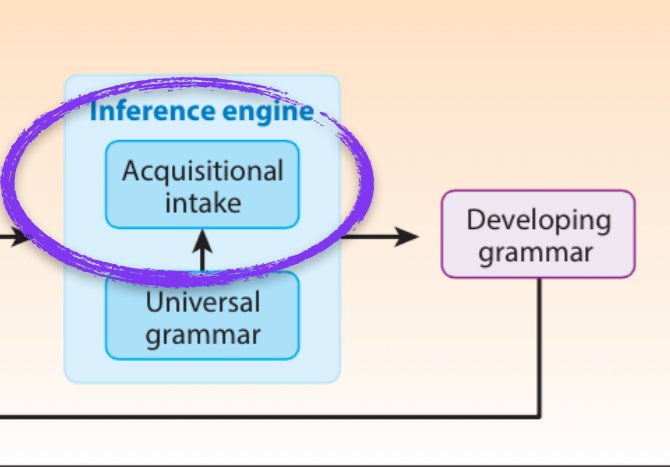

+movement

-animate
Subject
The ice seemed to melt.

NP _____ +past Snonfinite

Highest -movement
Theme



Agent > Experiencer >

Theme > Patient >

(Source, Goal, Instrument)

3yrs



-surfmorph
rUTAH

4yrs



+surfmorph
UTAH
-expmap

5yrs



+surfmorph
UTAH rUTAH
+expmap

3yrs



-surfmorph
rUTAH

4yrs



+surfmorph
UTAH
-expmap

5yrs

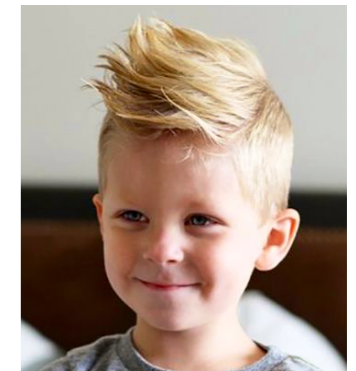

+surfmorph
UTAH rUTAH
+expmap

**What seems to develop earlier
(perhaps because it's easy to derive from existing biases):**

-surfmorph: Preference to ignore surface morphology
(perhaps due to processing limitations)

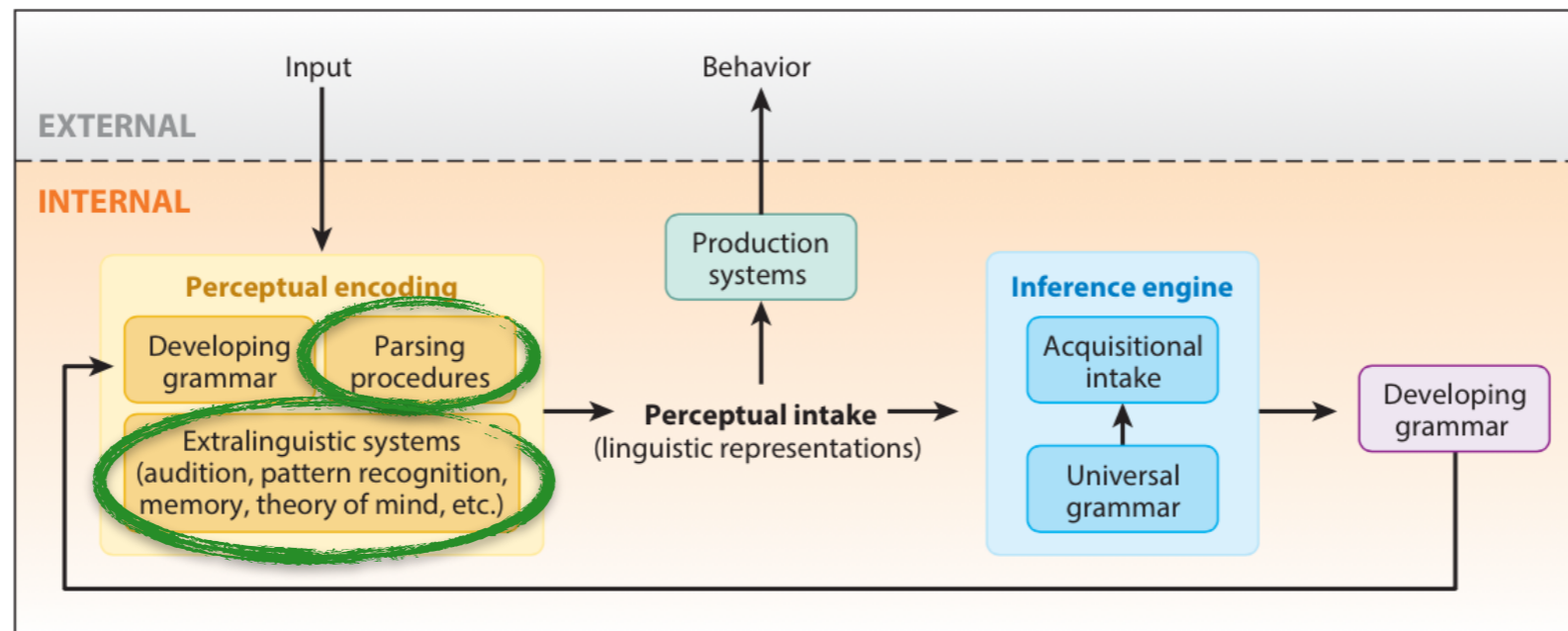

3yrs



-surfmorph
rUTAH

4yrs



+surfmorph
UTAH
-expmap

5yrs

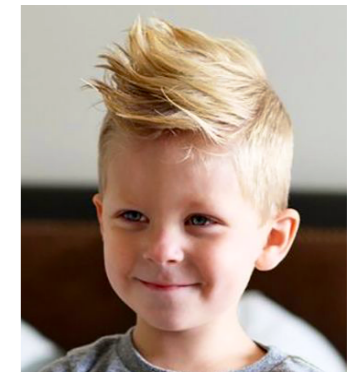

+surfmorph
UTAH rUTAH
+expmap

What seems to be available earlier (perhaps because it doesn't involve abstracting over conceptual information):

Agent > Experiencer >

Theme > Patient >

(Source, Goal, Instrument)

rUTAH: More detailed thematic representation

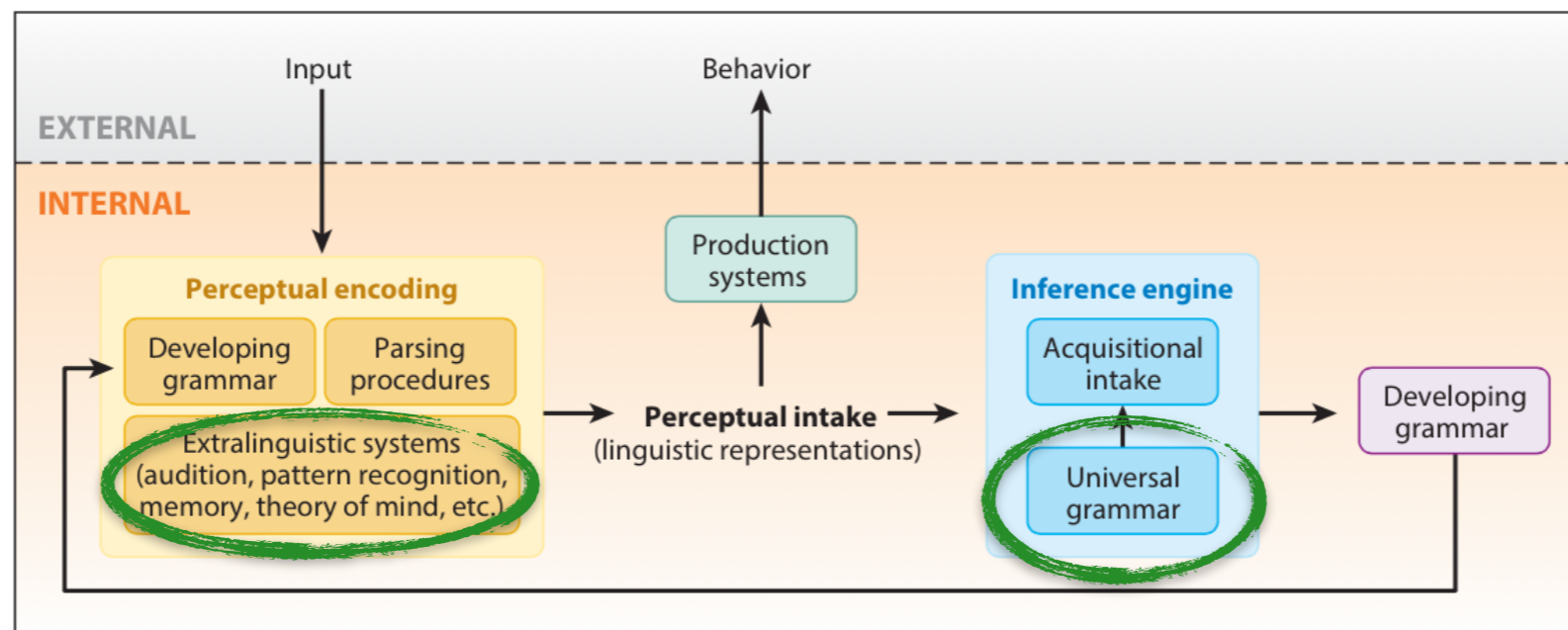

3yrs



-surfmorph
rUTAH

4yrs



+surfmorph
UTAH
-expmap

5yrs



+surfmorph
UTAH rUTAH
+expmap

What seems to develop somewhat earlier
(perhaps because it's easy to derive from
existing biases):



UTAH: More abstract, categorical
thematic representation

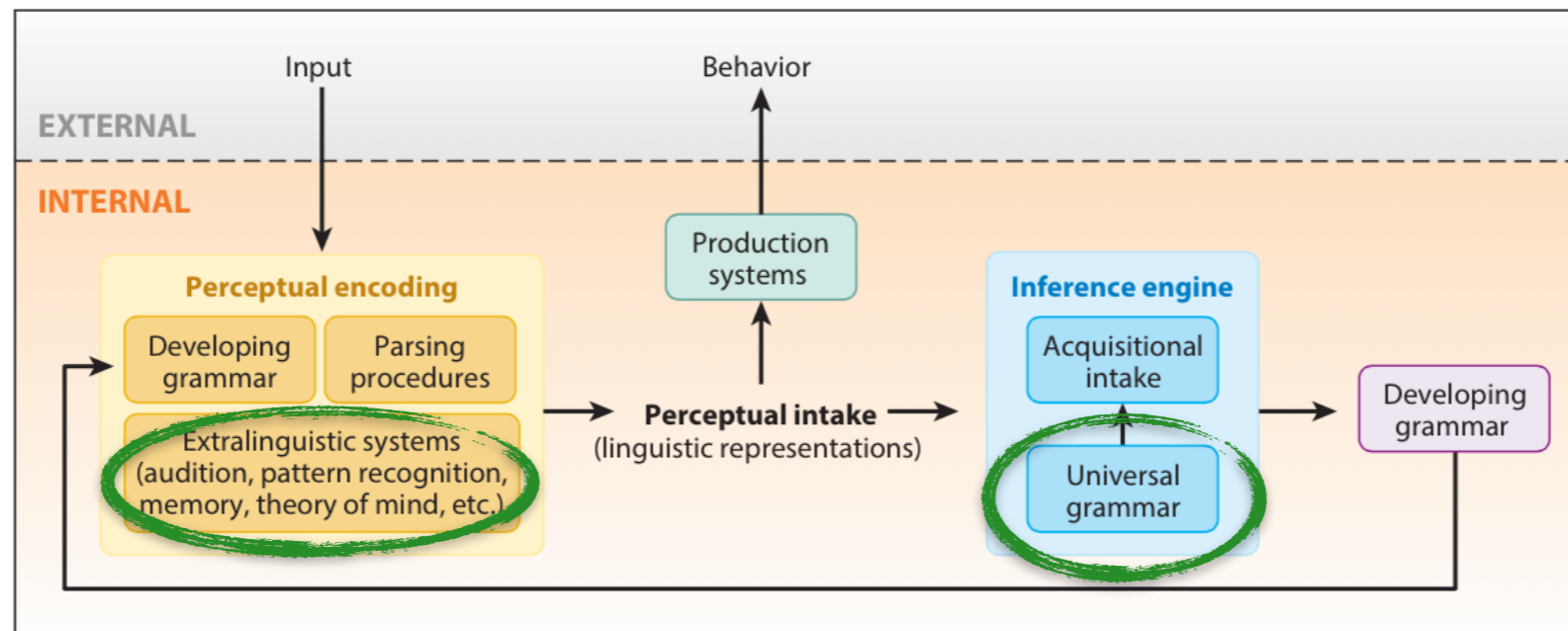

3yrs



-surfmorph
rUTAH

4yrs



+surfmorph
UTAH
-expmap

5yrs

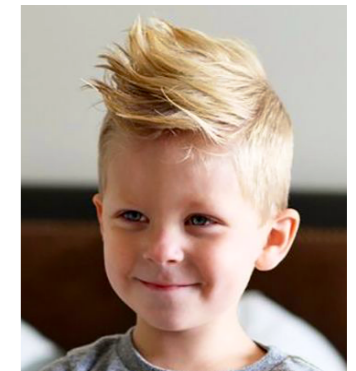

+surfmorph
UTAH rUTAH
+expmap

What seems to develop somewhat earlier
(perhaps because it's easy to derive from
existing biases):

Subject Object Indirect Object



-expmap: No prior expectation about
how to map — learn this from the intake

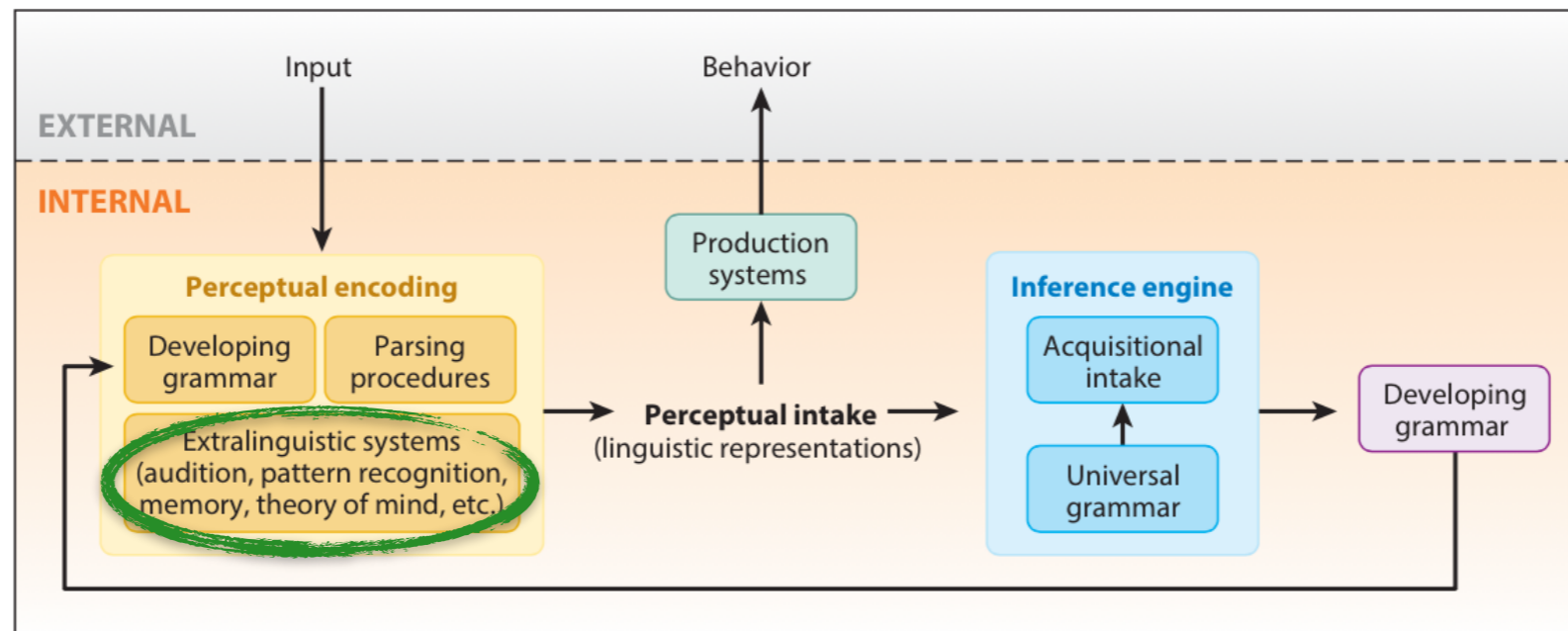

3yrs



-surfmorph
rUTAH

4yrs



+surfmorph
UTAH
-expmap

5yrs



+surfmorph
UTAH rUTAH
+expmap

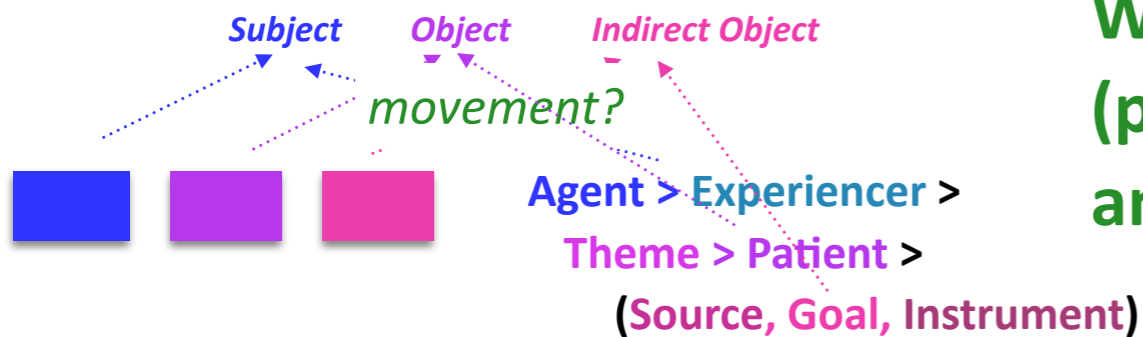

What seems to develop later
(perhaps building on prior knowledge
and the intake):

rUTAH, +expmap: more detailed
thematic representation coupled
with expectation of mapping

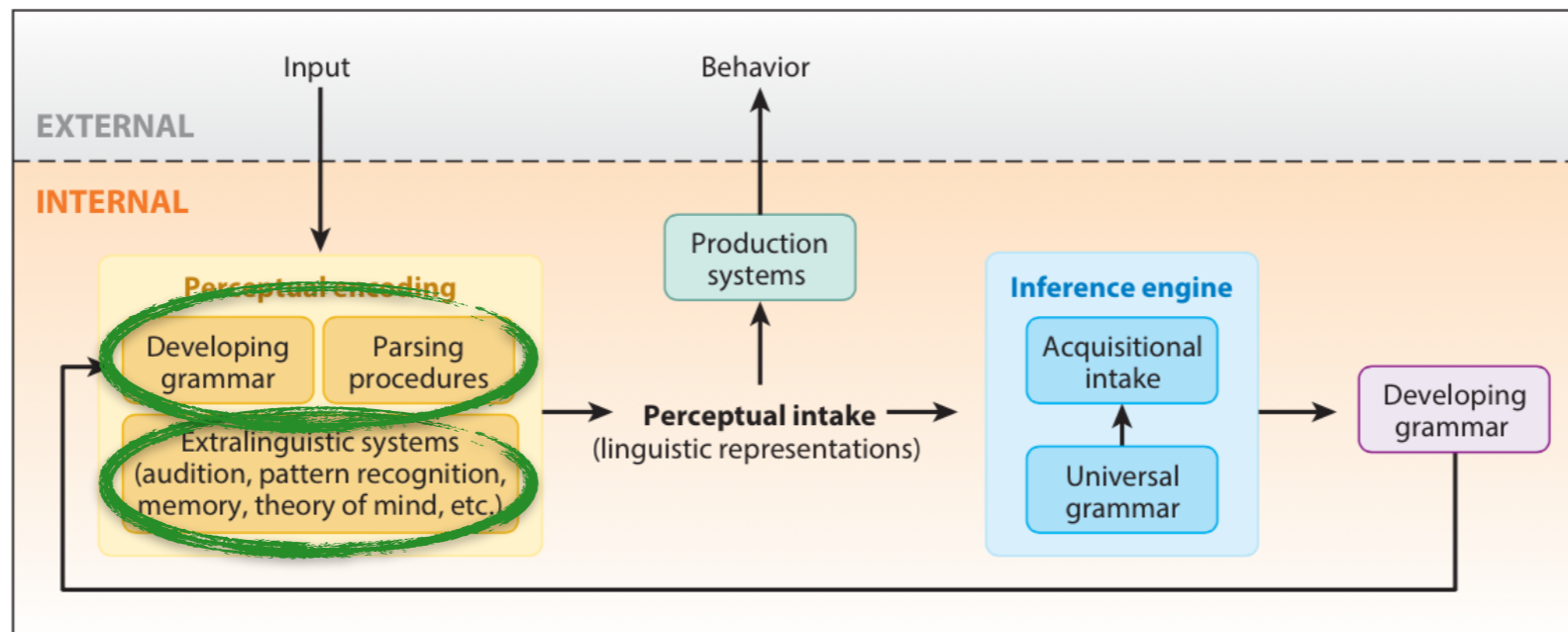

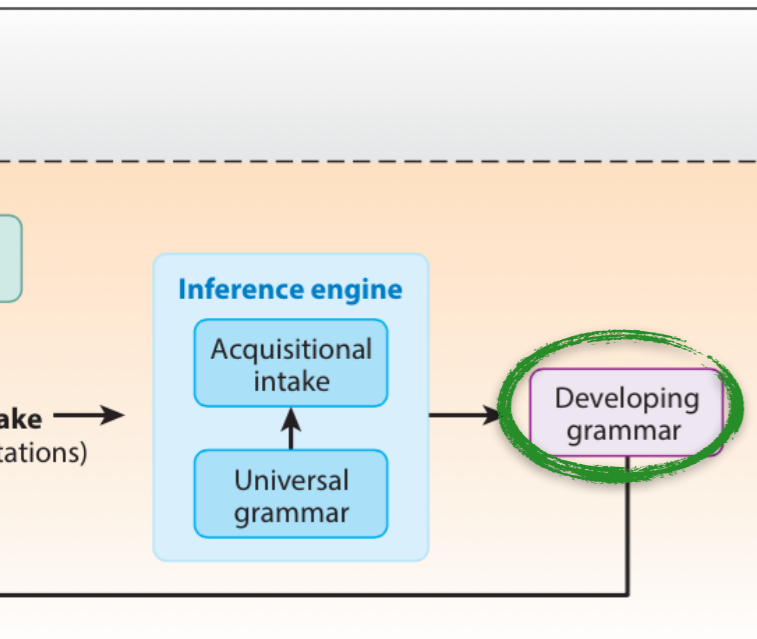

3yrs



-surfmorph
rUTAH

4yrs



+surfmorph
UTAH
-expmap

5yrs



+surfmorph
UTAH rUTAH
+expmap

Bigger theoretical takeaway:

Everyone's right about the representation at some stage of development.

+animate



-surfmorph
NP ___ S_{nonfinite}
+surfmorph
NP ___+past S_{nonfinite}

UTAH

rUTAH Agent > Experiencer >
Theme > Patient >
(Source, Goal, Instrument)

-expmap Subject Object Indirect Object

+expmap movement?

3yrs



-surfmorph
rUTAH

4yrs



+surfmorph
UTAH
-expmap

5yrs



+surfmorph
UTAH rUTAH
+expmap

So now what?



So now what?

3yrs



-surfmorph
rUTAH

4yrs



+surfmorph
UTAH
-expmap

5yrs

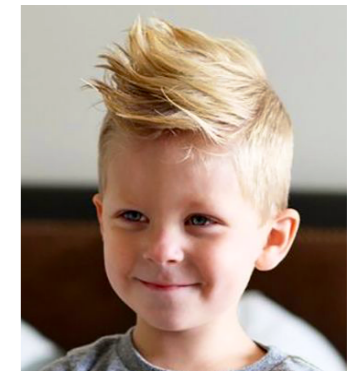

+surfmorph
UTAH rUTAH
+expmap

(1) A broader assessment of children's verb class knowledge



So now what?

3yrs

-surfmorph
rUTAH

4yrs

+surfmorph
UTAH
-expmap

5yrs

+surfmorph
UTAH rUTAH
+expmap



(1) A broader assessment of children's verb class knowledge

We need more observable behavior for more verbs in children's input to match modeling results against.

<3yrs



239 verbs
15 classes
of 60 verbs

<4yrs



267 verbs
23 classes
of 76 verbs

<5yrs



284 verbs
24 classes
of 82 verbs

Input

Children's behavior

So now what?

3yrs

-surfmorph
rUTAH

4yrs

+surfmorph
UTAH
-expmap

5yrs

+surfmorph
UTAH rUTAH
+expmap



(1) A broader assessment of children's verb class knowledge

This will further test these theoretical proposals, and validate (or not) the current findings.

<3yrs



239 verbs
15 classes
of 60 verbs

<4yrs



267 verbs
23 classes
of 76 verbs

<5yrs



284 verbs
24 classes
of 82 verbs

Input

Children's behavior

So now what?

3yrs

-surfmorph
rUTAH

4yrs

+surfmorph
UTAH
-expmap

5yrs

+surfmorph
UTAH rUTAH
+expmap



(1) A broader assessment of children's verb class knowledge

(a) More verbs

<3yrs



239 verbs
15 classes
of 60 verbs

<4yrs



267 verbs
23 classes
of 76 verbs

<5yrs



284 verbs
24 classes
of 82 verbs

Input

Children's behavior

So now what?

3yrs

-surfmorph
rUTAH

4yrs

+surfmorph
UTAH
-expmap

5yrs

+surfmorph
UTAH rUTAH
+expmap



(1) A broader assessment of children's verb class knowledge

(a) More verbs

(b) More behaviors

transitive
unergative *intransitive*

non-finite -ing
small clause
wager-class

<3yrs



239 verbs
15 classes
of 60 verbs

<4yrs



267 verbs
23 classes
of 76 verbs

<5yrs



284 verbs
24 classes
of 82 verbs

Input

Children's behavior

So now what?

(1) A broader assessment of children's verb class knowledge



experimental

3yrs

-surfmorph
rUTAH

4yrs

+surfmorph
UTAH
-expmap

5yrs

+surfmorph
UTAH rUTAH
+expmap

(2) Models incorporating more cognitively plausible assumptions

+memory & processing limitations

+predicting experimental behavior

+incorporating additional age-appropriate information

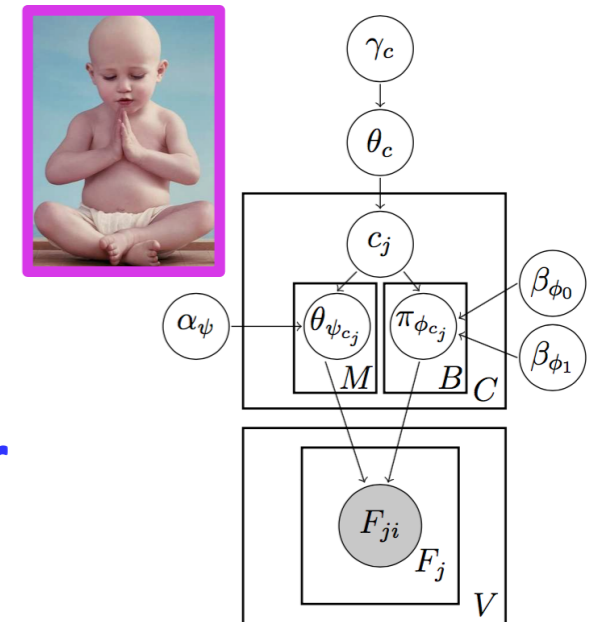

So now what?

(1) A broader assessment of children's verb class knowledge



experimental

3yrs

-surfmorph
rUTAH

4yrs

+surfmorph
UTAH
-expmap

5yrs

+surfmorph
UTAH rUTAH
+expmap

(2) Models incorporating more cognitively plausible assumptions

What happens when we embed these theories in a learning model that **learns incrementally** and has age-appropriate **memory & processing limitations**?

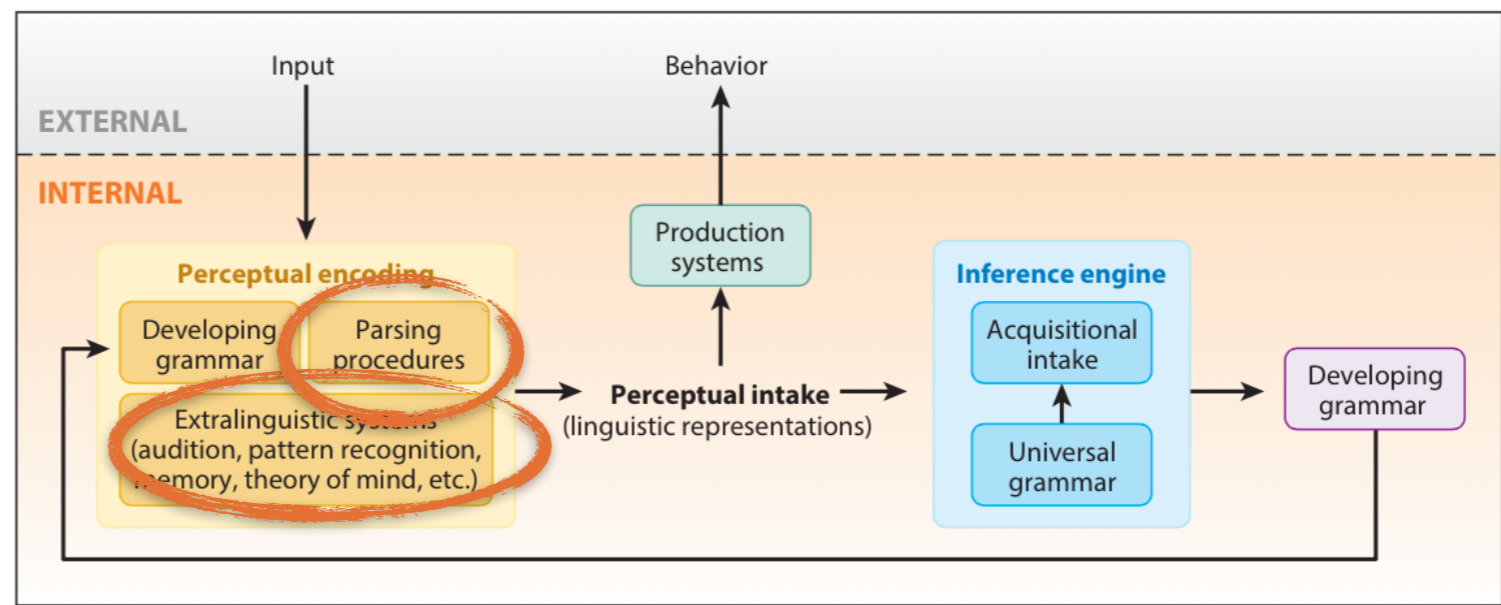
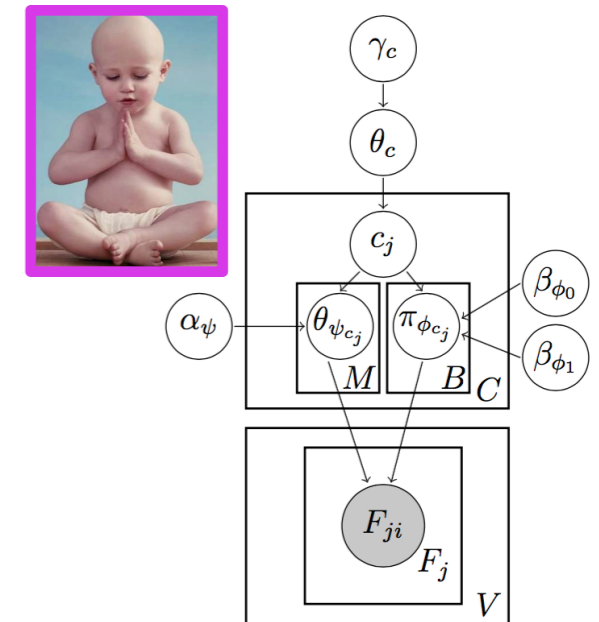

So now what?

(1) A broader assessment of children's verb class knowledge



experimental

3yrs

-surfmorph
rUTAH

4yrs

+surfmorph
UTAH
-expmap

5yrs

+surfmorph
UTAH rUTAH
+expmap

(2) Models incorporating more cognitively plausible assumptions

What kinds of child **behavior** does the model predict in the experimental scenarios already available, based on its **internal representations**?

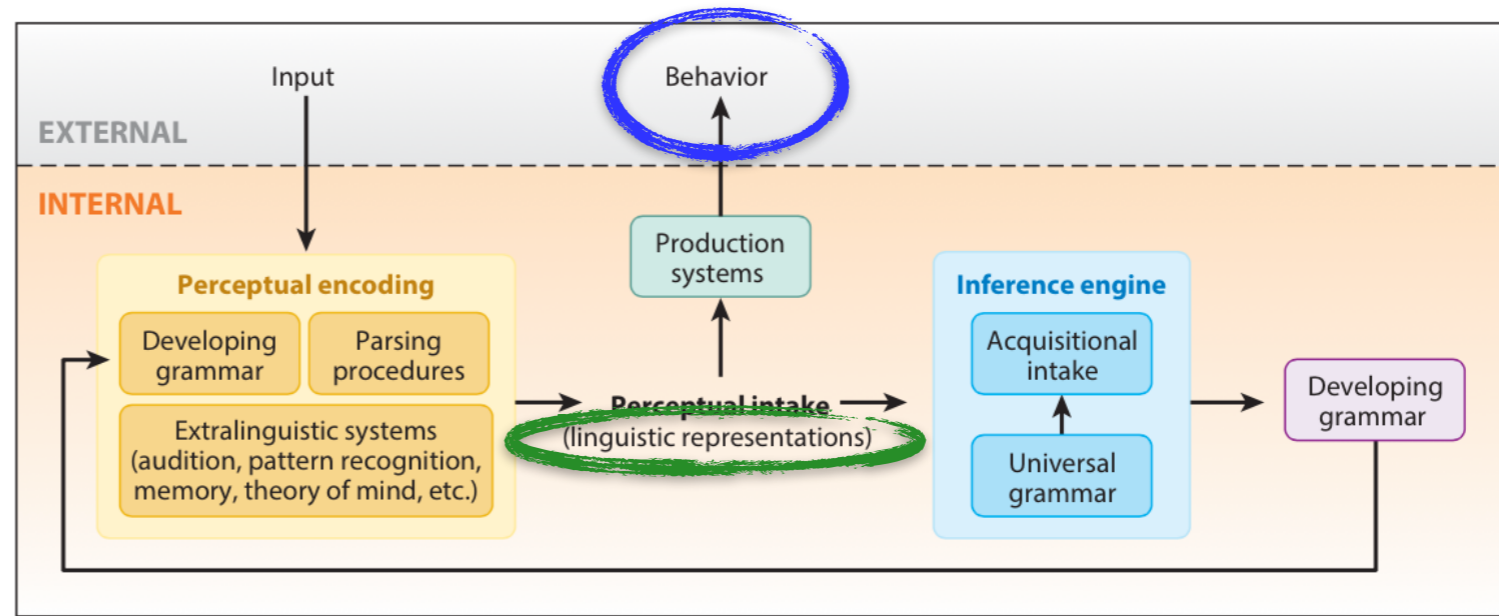
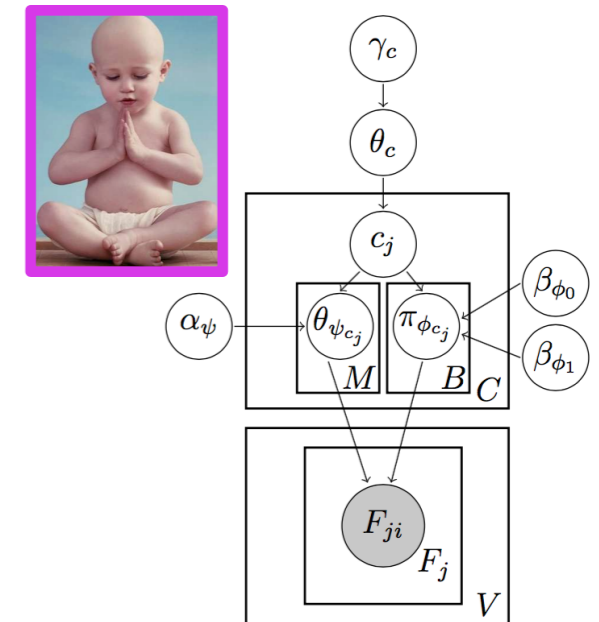

So now what?

(1) A broader assessment of children's verb class knowledge



experimental

3yrs

-surfmorph
rUTAH

4yrs

+surfmorph
UTAH
-expmap

5yrs

+surfmorph
UTAH rUTAH
+expmap

(2) Models incorporating more cognitively plausible assumptions

What other types of information may be available, especially throughout development as children learn from their intake?

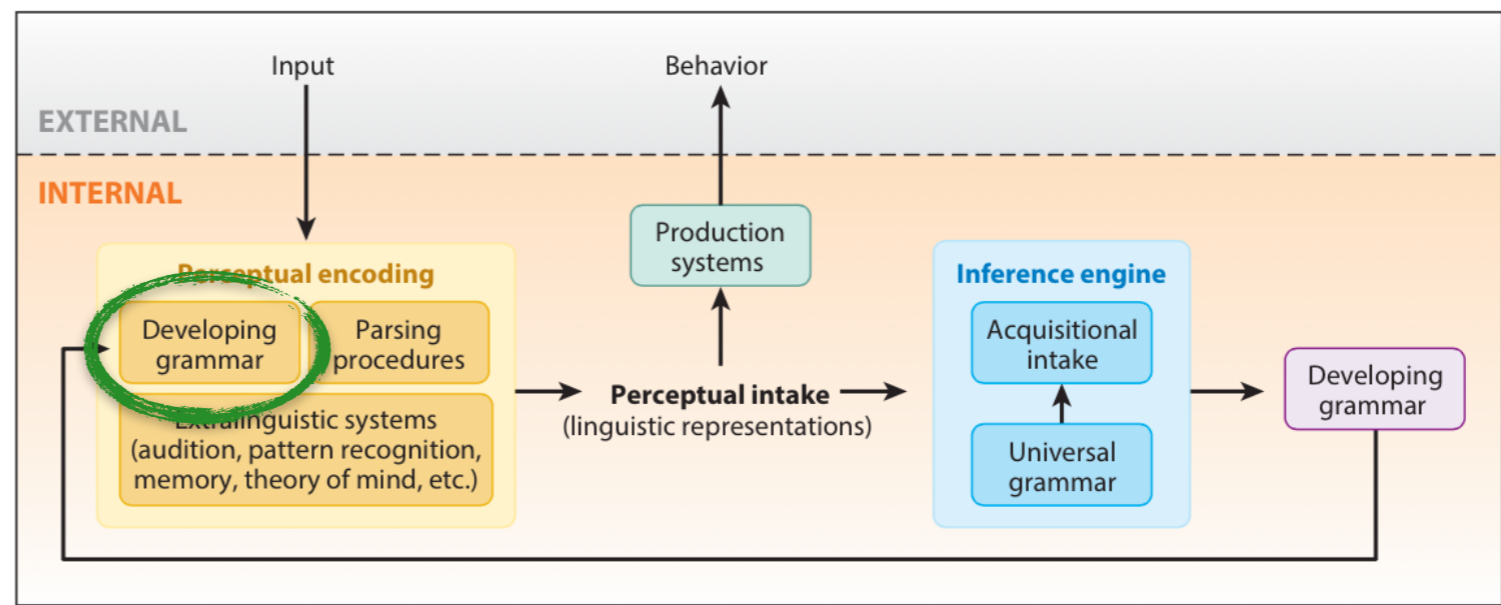
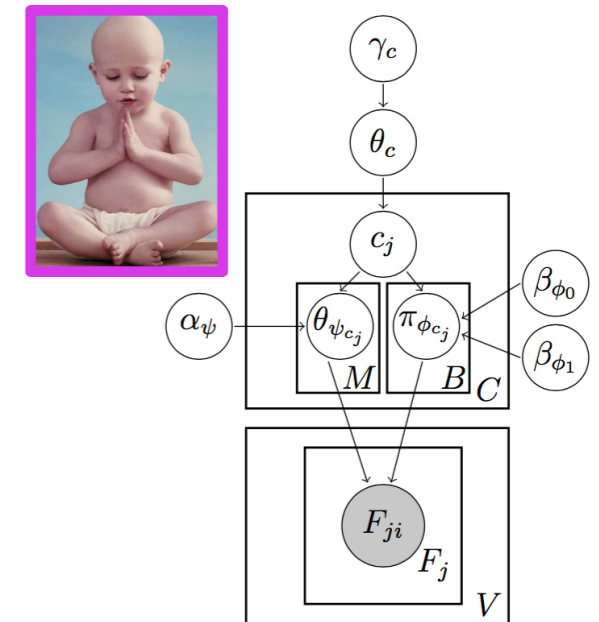

So now what?

(1) A broader assessment of children's verb class knowledge



experimental

3yrs

-surfmorph
rUTAH

4yrs

+surfmorph
UTAH
-expmap

5yrs

+surfmorph
UTAH rUTAH
+expmap

(2) Models incorporating more cognitively plausible assumptions

computational

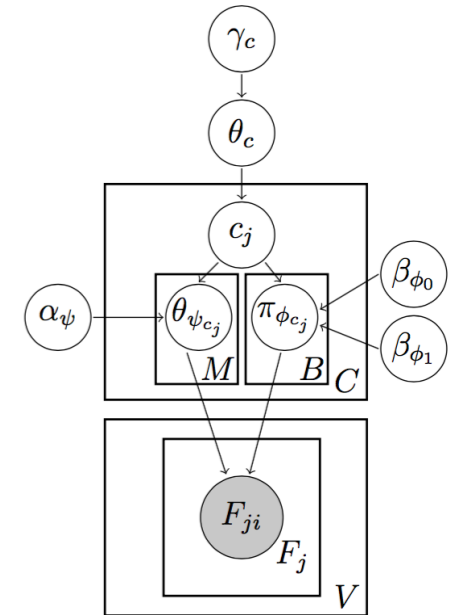

(3) Other theories of representation

Are there other options for linking thematic role information to syntactic structure that we can explore in this framework?



Agent > Experiencer >
Theme > Patient >
(Source, Goal, Instrument)



Subject

Object

Indirect Object

???

So now what?

(1) A broader assessment of children's verb class knowledge



experimental

3yrs

-surfmorph
rUTAH

4yrs

+surfmorph
UTAH
-expmap

5yrs

+surfmorph
UTAH rUTAH
+expmap

(2) Models incorporating more cognitively plausible assumptions

computational

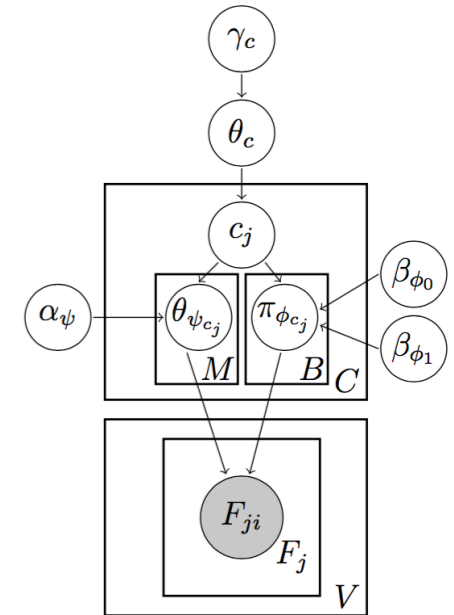

(3) Other theories of representation



Agent > Experiencer > ???
Theme > Patient >
(Source, Goal, Instrument)

theoretical

Subject Object Indirect Object